

Student Handbook

SERVICE OPERATOR TRAINING ON DRILLING & WELLSITE OPERATIONS



SAUDI ARABIAN DRILLING ACADEMY (SADA)

Published by SADA with support of Saudi Aramco Drilling & Workover

Jan 2019

Preface

The Service Operator Training On Drilling & Well-Site Operations textbook has been published in 2018 to serve as a reference book for Saudi Arabian Drilling Academy (SADA) students.

This textbook has been designed for entry level Junior operators working on Oil & Gas Operations. The textbook covers a wide range of topics and services related to Oil field service companies Operations both onshore and offshore. Furthermore, the textbook includes various practical assignments for the Service Operator to complete in order to capture the full experience of the daily operations and activities specifically those related to the Operators working on Pumping & Cementing Services, Wireline Logging and Slickline Services, Directional & MWD/LWD Drilling, Coiled Tubing Operations, Casing/Tubular Running Services, Mud Logging Services, Completions, and Other services.

The textbook is edited and intended to raise the knowledge of its readers on the subjects covered to the level of 'intermediate.' Therefore, this book can be considered as a reference for higher level of technical education on the Service Operator Training On Drilling & Well Site Operations.

It is worth mentioning that it would not have been possible to come up with this reference book without the generous support received from Neft Energies, Saudi Aramco and (SADA) stake holders.

SADA appreciates all stakeholders for their contribution to the program development.

Table of Contents

1	DRILLING, DRILL-IN AND COMPLETION FLUIDS	1
1.1	OBJECTIVES	1
1.2	OUTCOMES	1
1.3	DRILLING FLUIDS	1
1.3.1	Drilling Fluids	1
1.3.2	Fluid Pit	3
1.3.3	Functions of Drilling Fluids	3
1.3.4	Factors Influencing Drilling Fluid Performance	10
1.3.5	Drilling Fluid Classification	10
1.4	DRILL-IN FLUIDS	11
1.4.1	Clear Fluids with Viscous Sweeps	11
1.4.2	Hydroxy Ethyl Cellulose Fluids	11
1.4.3	Sized Salt Systems	11
1.4.4	VERSADRILT/VERSACLEANT/VERSAPOR™	12
1.4.5	NOVADRILT/NOVAPLUST/NOVATEC™	12
1.5	COMPLETION AND WORKOVER FLUIDS	13
2	BASIC MUD LOGGING	16
2.1	OBJECTIVES	16
2.2	OUTCOMES	16
2.3	OVERVIEW	16
2.4	MUD LOGGING UNIT	17
2.4.1	Types of Mud Logging Units	17
2.5	DUTIES & RESPONSIBILITIES	18
2.5.1	Mud Logging Unit Captain	18
2.5.2	Mud Logger	18
2.6	THE MUD LOGGING THEORY & LAG	18
2.6.1	Lag Definitions	18
2.6.2	Lag Equations	19
2.6.3	Lag Correction	20
2.7	TRIP MONITORING	20
2.7.1	Trip-In Monitoring Procedures	20
2.7.2	Trip-Out Monitoring Procedures	22

2.8	SAMPLE COLLECTION DESCRIPTION.....	23
2.8.1	Preparation for Collection of Cutting Samples.....	24
2.8.2	Shaker Samples.....	24
2.8.3	Collecting Cutting Samples.....	25
2.8.4	Contamination of Cuttings	25
2.9	TYPES OF RECORDED GASES.....	25
2.9.1	Cuttings Gas (formation gas).....	25
2.9.2	Factors Affecting the Size of the Gas Show	26
2.9.3	Background Gas.....	26
2.9.4	Trip Gas.....	27
2.9.5	Connection Gas.....	27
2.9.6	Circulation Gas.....	27
2.9.7	Kelly Gas	27
2.9.8	Carbide Gas.....	27
2.10	GAS DETECTION ANALYSIS AND MONITORING EQUIPMENT.....	28
2.10.1	Gas Trap Assembly	28
2.10.2	Total Gas Detector.....	28
2.10.3	Gas Chromatograph	28
2.10.4	Steam Still.....	28
2.11	SENSORS	29
2.11.1	Hook Load Sensor	30
2.11.2	Torque Sensors.....	30
2.11.3	Standpipe and Choke Pressure Sensor.....	30
2.11.4	Analog Rotary Speed Sensor	31
2.11.5	Pit Volume Sensors.....	31
2.11.6	Flow Out Sensor	31
2.11.7	Temperature Sensors	31
2.11.8	Mud Density Sensor	32
2.11.9	Mud Conductivity Sensor	32
2.11.10	Depth Sensor	32
2.11.11	Pump Stroke Sensor	33
2.11.12	Digital Rotary Speed Sensor	33
2.12	GAS TRAP ASSEMBLY.....	33

2.13	HYDROGEN SULPHIDE GAS DETECTOR.....	33
3	DIRECTIONAL DRILLING	35
3.1	OBJECTIVES.....	35
3.2	OUTCOMES.....	35
3.3	OVERVIEW	35
3.4	APPLICATIONS	35
3.4.1	Multiple Wells from Offshore Structures	35
3.4.2	Relief Wells.....	36
3.4.3	Controlling Vertical Wells	36
3.5	PROCEDURES.....	39
3.5.1	Arrival at Rig Site	39
3.5.2	Equipment Receiving.....	39
3.6	RIG UP PROCEDURE.....	40
3.7	EQUIPMENT AND TOOLS.....	41
3.7.1	Mud Motor	41
3.7.2	Rotary Steerable System (RSS)	43
3.7.3	Measurements While Drilling MWD	43
3.7.4	Logging While Drilling LWD	44
3.7.5	Real Time Data Log.....	45
3.8	DIRECTIONAL DRILLING LIMITATION.....	45
4	CEMENTING	47
4.1	OBJECTIVES.....	47
4.2	OUTCOMES.....	47
4.3	OVERVIEW	47
4.4	HISTORY OF PORTLAND CEMENT	47
4.5	CEMENT MANUFACTURING	47
4.5.1	Raw Materials.....	47
4.5.2	Raw Materials.....	48
4.5.3	Manufacturing Process Procedures	48
4.5.4	Manufacturing Process Schematics.....	48
4.6	CEMENT TYPES	49
4.7	ADDITIVES.....	50
4.8	COMMONLY MEASURED CEMENT PROPERTIES	51

4.9	LABORATORY PROCEDURE AND METHODS OF REPORTING	51
4.10	PRIMARY CEMENTING	51
4.10.1	Stage Cementing (Single Stage).....	51
4.10.2	Stage Cementing (Multi Stage).....	53
4.10.3	Inner String Cementing.....	54
4.11	SQUEEZE CEMENTING JOBS	55
4.11.1	High Pressure Squeeze	55
4.11.2	Low Pressure Squeeze	55
4.12	CEMENT PLUGS	56
4.13	CEMENT PREPERATION	56
4.14	CEMENTING A WELL.....	58
4.15	ACCESSORIES	58
4.15.1	Float Shoe	58
4.15.2	Float Collar.....	59
4.15.3	DV Tool-Stage-cementing tools.....	59
4.15.4	Centralizer	60
4.15.5	Stop Collar	61
4.15.6	Wall Scratchers	61
4.16	RUNNING TOOLS	62
4.16.1	Casing Scraper	62
4.16.2	Watermelon Mill	62
5	LINER HANGER.....	64
5.1	DEFINITION.....	64
5.2	TYPICAL LINER ASSEMBLY.....	64
5.3	REASONS FOR RUNNING LINERS	65
5.4	LINERS TYPES	66
5.4.1	Drilling Liner.....	66
5.4.2	Production Liner	66
5.4.3	Scab or Stub Liner	66
5.4.4	Tie-Back Liner	66
5.5	CONSIDERATION IN SELECTING TYPE OF LINER HANGER TO USE.....	67
5.6	COMMON COMPONENTS IN LINER APPLICATIONS	67
5.6.1	Liner-Top Polished Bore Receptacle (PBR)	68

5.6.2	Liner Top Packer OR Liner Setting Sleeve	69
5.6.3	Cementing Pack-off	69
5.6.4	Liner Hanger	69
5.6.5	Landing Collar	71
5.6.6	Float Equipment	72
5.7	CEMENT DISPLACEMENT SYSTEM	73
5.7.1	Liner Wiper Plug	73
5.7.2	Pump Down Plug (drill pipe dart).....	73
5.8	OIL FIELD PRACTICAL PROCEDURE	74
5.8.1	Running a Hydraulic Liner Hanger with a Weight Set Packer.....	74
6	UNDER BALANCE DRILLING.....	78
6.1	WHAT IS UNDERBALANCED DRILLING?	78
6.2	WHY DRILL UNDERBALANCED?	79
6.3	DRILLING FLUID SYSTEMS.....	79
6.3.1	Gaseous Fluid	80
6.3.2	Mist System	80
6.3.3	Gasified Systems Gas.....	80
6.4	DOWN HOLE EQUIPMENT FOR UBD OPERATIONS	81
6.4.1	Pressure While Drilling Sensor "PWD"	81
6.4.2	Conventional MWD Tools in UBD.....	81
6.4.3	Electromagnetic Measurement While Drilling (EMWD)	82
6.4.4	Non-return Valves	82
6.4.5	Deployment Valves.....	82
6.5	UBD OPERATIONS SURFACE EQUIPMENT	83
6.5.1	Drilling Systems	83
6.5.2	Gas-generation Equipment	83
6.5.3	Well-Control Equipment.....	84
6.5.4	Surface Separation Equipment.....	85
6.6	UNDER BALANCED DRILLING TECHNICAL LIMITATION	86
6.6.1	Wellbore Stability	86
6.6.2	Water Inflow.....	86
6.6.3	Directional Drilling Equipment	86
6.6.4	Unsuitable Reservoir	86

6.6.5	Safety and Environment	86
6.6.6	Surface Equipment	86
6.6.7	Personnel.....	86
7	MANAGED PRESSURE DRILLING (MPD)	87
7.1	OVERVIEW	87
7.2	DEFINITION OF BASIC CONCEPTS	87
7.2.1	Formation Pore Pressure.....	87
7.2.2	Overburden Pressure	87
7.2.3	Fracture Pressure	88
7.2.4	Hydrostatic Pressure (Ph).....	88
7.2.5	Bottom Hole Pressure (BHP)	88
7.3	CONVENTIONAL DRILLING METHOD.....	88
7.4	HOW TO MANAGE PRESSURE	89
7.4.1	Managed Pressure Drilling Definition	89
7.4.2	MPD Benefits.....	90
7.4.3	Narrow Pressure Windows.....	90
7.4.4	Managed Pressure Drilling Techniques	91
7.4.5	Limitations of MPD	91
7.4.6	Managed Pressure Drilling Tools.....	92
8	WELL COMPLETION	94
8.1	OBJECTIVES.....	94
8.2	OUTCOMES.....	94
8.3	OVERVIEW	94
8.4	COMPLETION DEFINITION	95
8.5	TYPES OF COMPLETION	95
8.6	WHY WE NEED TO PERFORATE THE WELL?	97
8.7	FACTORS INFLUENCING WELL COMPLETION SELECTION.....	98
8.8	TYPE OF FLOW	98
8.9	COMMON COMPLETION EQUIPMENTS	98
8.9.1	Well head/X-Mass Tree	99
8.9.2	Production Tubing	100
8.9.3	Production Packer	101
8.9.4	TUBING ANCHOR CATCHER.....	102

8.9.5	Landing Nipple.....	103
8.9.6	Slide Side Door (SSD).....	104
8.9.7	Control Line.....	104
8.9.8	Sub-Surface Safety Valve (SSSV).....	104
8.9.9	Side Pocket Mandrel (SPM).....	105
8.9.10	Polished Bore Receptacle (PBR).....	105
8.9.11	Flow Coupling.....	105
8.9.12	Tubing Hanger.....	106
8.9.13	Blast Joint.....	106
8.9.14	Wire Line Entry Guide (WLEG).....	107
8.9.15	Perforated Pup Joint.....	107
8.9.16	Pup Joint.....	108
8.9.17	Cross Over.....	108
9	WIRELINE, SLICKLINE, WIRELINE LOGS AND PERFORATIONS.....	110
9.1	OBJECTIVES.....	110
9.2	OUTCOMES.....	110
9.3	OVERVIEW.....	110
9.4	THE DIFFERENCE BETWEEN SLICKLINE AND WIRE LINE.....	112
9.5	BENDING STRESSES.....	114
9.6	RE-SPOOLING.....	114
9.7	HANDLING AND STORAGE.....	115
9.8	TESTING WIRELINE IN SERVICE.....	115
9.9	WIRELINE FAILURE.....	116
9.9.1	Hydrogen Embrittlement.....	116
9.9.2	Age Hardening.....	116
9.9.3	Fatigue.....	116
9.9.4	Corrosion.....	116
9.9.5	Corrosion Fatigue.....	116
9.9.6	Stress Corrosion.....	116
9.9.7	Tensile Overload.....	116
9.9.8	Snarl.....	117
9.9.9	Hydrodynamic Deformation.....	117
9.10	WIRELINE SURFACE EQUIPMENT.....	117

9.10.1	Quick Unions.....	118
9.10.2	Wellhead Adapter (tree adapter).....	120
9.10.3	Pump in tee	120
9.10.4	Wireline Valve/Blow Out Preventer (BOP).....	121
9.10.5	Lubricators.....	121
9.10.6	Injection Sub (Optional).....	122
9.10.7	Stuffing box (alternate sealing wiper box, grease injector head)	122
9.10.8	Wireline Unit	123
9.10.9	Hay Pulley	125
9.10.10	Martin Decker Weight Indicator Sensor.....	126
9.10.11	Measuring Wheel	126
9.10.12	Wireline Clamp	127
9.11	WIRELINE LOGS AND TOOLS.....	127
9.11.1	Natural Gamma Ray Tools.....	128
9.11.2	Nuclear Tools.....	128
9.11.3	Resistivity Tools	129
9.11.4	Sonic and Ultrasonic Tools	129
9.11.5	Nuclear Magnetic Resonance Tools	129
9.11.6	Cement Bond Tools	130
9.11.7	Casing Collar Locators.....	130
9.11.8	CCL Log	130
9.11.9	Gamma Perforating Tools.....	131
9.11.10	Wireline Pressure Setting Assemblies (WLSPA)	131
9.11.11	Cable Head.....	131
9.11.12	Tractors.....	132
9.11.13	Measuring Head	132
9.12	PERFORATION.....	132
9.12.1	Perforated vs. Open hole.....	132
9.12.2	Bullets, Jets, or Hydraulic	132
10	COILED TUBING	135
10.1	OBJECTIVES.....	135
10.2	OUTCOMES.....	135
10.3	OVERVIEW	135

10.4	APPLICATIONS	136
10.4.1	Circulation	136
10.4.2	Pumping.....	136
10.4.3	Coiled Tubing Drilling (CTD).....	137
10.4.4	Logging and Perforating	137
10.4.5	Production	138
10.5	MAIN PARTS OF A CT SYSTEM	138
10.5.1	Tubing Injector Assembly	140
10.5.2	Tubing Guide Arch	140
10.5.3	Service Reel	141
10.5.4	Power Supply / Prime Mover	142
10.5.5	Control Console & Monitoring System.....	143
10.5.6	Well Control Equipment	144
10.6	RIG UP.....	145
10.7	TASKS.....	145
11	WELL STIMULATION BY ACIDIZING.....	147
11.1	OBJECTIVES.....	147
11.2	OUTCOMES.....	147
11.3	OVERVIEW	147
11.4	ACID REQUIREMENTS.....	147
11.5	USES OF ACID.....	148
12	WELL STIMULATION BY FRACTURING.....	149
12.1	OBJECTIVES.....	149
12.2	OUTCOMES.....	149
12.3	OVERVIEW	149
12.4	EQUIPMENT.....	150
12.4.1	Engines	150
12.4.2	Pumps.....	150
12.4.3	Intensifiers.....	151
12.4.4	Blenders.....	151
12.4.5	Frac Tanks.....	151
12.4.6	Standby Equipment Considerations	152
12.4.7	Gauges and Controls	152

12.4.8	Bridge Plugs	152
12.4.9	Crossover Valve	152
12.4.10	Wellhead Equipment	153
12.4.11	Diverting Agents	153
12.4.12	Fluids.....	153
12.4.13	Frac String.....	153
12.4.14	Packers.....	154
12.4.15	Perforation Ball Sealers	154
12.4.16	Foam Frac Equipment.....	154
12.4.17	Proppant.....	155
12.4.18	Radioactive Sand	155
12.5	IMPLEMENTING THE JOB.....	155
12.5.1	Site and Well Preparation.....	155
12.5.2	Perforating.....	155
12.6	RIG-UP	156
12.6.1	Proppant.....	156
12.6.2	Placement of Equipment - Safety Considerations.....	157
12.6.3	Fluid Mixing	157
12.6.4	BOP	157
12.7	RIG-DOWN.....	158
12.7.1	Evaluation and Testing	158
13	WELL TESTING	160
13.1	OBJECTIVES.....	160
13.2	OUTCOMES.....	160
13.3	OVERVIEW	160
13.4	PURPOSE OF WELL TESTING.....	160
13.4.1	Exploration wells	160
13.4.2	Producing wells.....	161
13.5	TYPES OF WELL TESTING	161
13.5.1	Flow test	161
13.5.2	RFT	161
13.5.3	Drill-Stem test.....	161
13.5.4	Drawdown test	162

13.5.5	Multirate tests	163
13.5.6	Production test	163
13.5.7	Buildup test	163
13.5.8	Banker's Test	163
13.5.9	Interference test.....	163
13.6	WELL TESTING EQUIPMENT	164
13.6.1	Surface Safety Valve "SSV"	164
13.6.2	Floor Choke Manifold	165
13.6.3	Steam-Heat Exchanger	165
13.6.4	Conventional Horizontal Separator	165
13.6.5	Vertical Surge Tank.....	165
13.6.6	High-Efficiency Burners	165
13.6.7	Surface Test Tree	165
13.6.8	Emergency Shutdown (ESD) System	166
13.6.9	Choke Manifold	167
13.6.10	Choke Bean.....	167
13.6.11	Data Header.....	168
13.6.12	3-Phase Test Separator.....	169
13.6.13	Vertical Surge Tank.....	170
13.6.14	Atmospheric Gauge Tank	170
13.6.15	Oil and Gas Manifold	171
13.6.16	Crude Oil Transfer Pumps.....	172
13.6.17	Gas Flare with Igniter	172
13.6.18	Crude Oil Burner.....	173
13.6.19	Steam Heat Exchanger	173

TABLE OF FIGURES

Figure 1 Oil Based Mud Mixing.....	2
Figure 2 Waste Pit	3
Figure 3 Fly Ash Absorbent for Fluids in Mud Pits.....	3
Figure 4 Cutting transport to shale shaker.....	4
Figure 5 Transport velocity = Annular velocity-Slip velocity	4
Figure 6 Solids removal at the shale shaker	5
Figure 7 Blowout at an Offshore Rig	5
Figure 8 Proper drilling fluid selection reduces formation damage.....	7
Figure 9 Drill string Rotation causes friction and heat.....	7
Figure 10 Buoyancy provides support for drill string	8
Figure 11 Mud logging unit	17
Figure 12 Mud logging unit	18
Figure 13 Sample collection description	23
Figure 14 Shaker sample	24
Figure 15 Table for screen size	24
Figure 16 Microscope	25
Figure 17 Gas sensor	27
Figure 18 Gas monitoring equipment	28
Figure 19 Junction box.....	29
Figure 20 hook load sensor	30
Figure 21 Torque sensor.....	30
Figure 22 Stand pipe manifold	30
Figure 23 Pit volume sensor	31
Figure 24 Flow paddle type	31
Figure 25 Mud Density sensor.....	32
Figure 26 Mud conductivity sensor	32
Figure 27 PVT.....	32
Figure 28 Pump stroke sensor.....	33
Figure 29 H ₂ S gas detector.....	33
Figure 30 Multiple wells from offshore structures	35
Figure 31 Relief Well.....	36
Figure 32 Controlling Vertical Wells	36
Figure 33 Side Tracking.....	36
Figure 34 Accessing multiple sands with side track laterals from a main wellbore.....	37
Figure 35 Drilling directional wells beneath natural surface obstructions	37
Figure 36 Fault Drilling	37
Figure 37 Salt Dome Drilling	38
Figure 38 Shore Drilling	38
Figure 39 MWD/LWD Cabin	39
Figure 40 Hook Load Sensor and Drawwork Encoder	40
Figure 41 Pump stroke sensor.....	40
Figure 42 Pressure tracking sensor	41
Figure 43 Mud Motor	41

Figure 44 Rotary steerable system (RSS).....	43
Figure 45 MWD Resistivity and Gamma Tool.....	43
Figure 46 Real Time Log	45
Figure 47 Wet Process for Manufacturing of Cement	48
Figure 48 Dry Process for Manufacturing of Cement.....	49
Figure 49 Single Stage Cementing Job.....	52
Figure 50 Cementing Head.....	52
Figure 52 Multi-Stage Cementing Job	53
Figure 53 Inner String Cementing Job	54
Figure 54 Cementing operation.....	57
Figure 55 Float (guide) shoe.....	58
Figure 56 Float collar	59
Figure 57 DV tool for stage cementing.....	60
Figure 58 Centralizers.....	60
Figure 59 Stop Collar	61
Figure 60 Scratcher.....	61
Figure 61 Casing scraper.....	62
Figure 62 String Mill	62
Figure 63 Liner hanger system components	64
Figure 64 Drilling liner	66
Figure 65 Production liner	66
Figure 66 Scab/stub liner.....	66
Figure 67 Tie-back liner	66
Figure 68 Common liner components and setting tool	67
Figure 69 Liner-top polished bore receptacle (PBR)	68
Figure 70 Liner Top Packer	69
Figure 71 Mechanical liner hanger.....	70
Figure 72 Hydraulic liner hanger	70
Figure 73 Landing collar	71
Figure 74 Float shoe	72
Figure 75 Float collar	72
Figure 76 Reamer shoe.....	72
Figure 77 Liner wiper plug.....	73
Figure 78 Drill pipe dart.....	73
Figure 79 Hydrostatic and formation pressure relationship	78
Figure 80 Different underbalance drilling fluid system.....	79
Figure 81 Gas lift system	80
Figure 82 Pressure while drilling sensor “PWD”	81
Figure 83 Measuring while drilling “MWD”	81
Figure 84 Electromagnetic measurement while drilling “EMWD”	82
Figure 85 Deployment valve.....	82
Figure 86 UBD Surface equipment	83
Figure 87 Nitrogen generation	84
Figure 88 Underbalance system.....	84

Figure 89 Rotating diverter system	85
Figure 90 Rotating BOP's.....	85
Figure 91 Leak off test	88
Figure 92 Static Pressure Vs. Dynamic Pressure	89
Figure 93 Drilling window.....	90
Figure 94 Rotating control device (RCD)	92
Figure 95 Typical well completion diagram.....	95
Figure 96 Wellbore interface completion types.....	96
Figure 97 Production method completion types	96
Figure 98 Zonal Production methods	97
Figure 99 Perforation operation.....	97
Figure 100 Common completion equipment	98
Figure 101 Well head.....	99
Figure 102 Well head configuration	100
Figure 103 Production tubing.....	100
Figure 104 Production packer	101
Figure 105 Production packer types.....	102
Figure 106 Tubing Anchor catcher	102
Figure 107 Bottom No-Go/ Top No-Go	103
Figure 108 Nipple with plug set.....	103
Figure 109 Slide side door" SSD"	104
Figure 110 Sub surface safety valve	104
Figure 111 Side pocket mandrel (SPM)	105
Figure 112 Tubing Hanger	106
Figure 113 Blast Joint	106
Figure 114 Wire line entry guide (WLEG).....	107
Figure 115 Perforated Pup joint	107
Figure 116 Wireline	111
Figure 117 Wireline and Slickline truck.....	112
Figure 118 Slickline firing head system	113
Figure 119 Inside a Wireline truck.....	114
Figure 120 Sekil 1 Re-spooling.....	115
Figure 121 Otis and Bowen Quick unions.....	118
Figure 122 O Ring seals.....	119
Figure 123 Well head adapter	120
Figure 124 Pump in tree	120
Figure 125 Lubricator	121
Figure 126 Injection sub	122
Figure 127 Stuffing box.....	123
Figure 128 Wireline unit and Power Pack	124
Figure 129 Slickline unit.....	124
Figure 130 Wireline unit controls.....	125
Figure 131 Measuring wheel.....	126
Figure 132 Wireline clamp	127

Figure 133 Gamma and Electronic tools	128
Figure 134 Casing Collar Log	131
Figure 135 relative “performances” of shaped-charge jet and hydraulic abrasive perforating	133
Figure 136 Shaped Charge.....	133
Figure 137 Coiled tubing pumping	136
Figure 138 Coiled tubing drilling (CTD).....	137
Figure 139 Coiled tubing perforation	137
Figure 140 Coiled tubing production.....	138
Figure 141 Coiled tubing unit	139
Figure 142 Coiled tubing components	139
Figure 143 Injector head	140
Figure 144 Tubing guide arch	140
Figure 145 Service reel	141
Figure 146 CT Reel side view	142
Figure 147 Power supply / prime mover	143
Figure 148 Control cabin	143
Figure 149 Well control equipment	144
Figure 150 General coiled tubing rig up	145
Figure 151 Matrix Stimulation.....	147
Figure 152 Acid reaction enlarges pore spaces.....	148
Figure 153 Fracture Orientation.....	149
Figure 154 Fracturing pump	150
Figure 155 Frac Blender.....	151
Figure 156 Frac Tank	152
Figure 157 Rig-up Frac pumps to Well Head	153
Figure 158 Foam Frac equipment on location	154
Figure 159 Rig-up of Fracturing Equipment	156
Figure 160 Sand King	156
Figure 161 Pressure Recovery Chart	162
Figure 162 General Layout	164
Figure 163 Surface Safety Valve SSV	164
Figure 164 Surface Test Tree	165
Figure 165 Emergency Shutdown System	166
Figure 166 Choke manifold	167
Figure 167 Adjustable Choke Bean.....	167
Figure 168 Fixed choke bean.....	168
Figure 169 Data Header.....	168
Figure 170 Three phase separator	169
Figure 171 Surge tank.....	170
Figure 172 Atmospheric Gauge Tank	170
Figure 173 Oil and Gas Manifold	171
Figure 174 Crude oil transfer pumps.....	172
Figure 175 Igniter	172
Figure 176 Burner	173

Figure 177 Steam exchanger 174

1 DRILLING, DRILL-IN AND COMPLETION FLUIDS

1.1 OBJECTIVES

After studying this section, the trainees should be able to perform the following:

- Describe the function of drill in fluids
- Describe the function of all components involved in preparing drill in fluids.
- Describe the operational procedures
- Describe operator's general safety precautions and emergency response procedures

1.2 OUTCOMES

Upon completing their training, the participants should be able to:

- Assist in various duties associated with tools and equipment for pumping slurries at the rig site
- Demonstrate an ability to understand general mixing processes and procedures

1.3 DRILLING FLUIDS

They are often used while drilling oil and natural gas wells and on exploration drilling rigs. Drilling fluids are also used for much simpler boreholes, such as water wells. Liquid drilling fluid is often called drilling mud. The three main categories of drilling fluids are water-based muds (which can be dispersed and non-dispersed), non-aqueous muds, usually called oil-based mud, and gaseous drilling fluid, in which a wide range of gases can be used.

The main functions of drilling fluids include providing hydrostatic pressure to prevent formation fluids from entering into the well bore, keeping the drill bit cool and clean during drilling, carrying out drill cuttings, and suspending the drill cuttings while drilling is paused and when the drilling assembly is brought in and out of the hole. The drilling fluid used for a particular job is selected to avoid formation damage and to limit corrosion.

1.3.1 Drilling Fluids

Many types of drilling fluids are used on a day-to-day basis. Some wells require that different types be used at different parts in the hole, or that some types be used in combination with others. The various types of fluid generally fall into a few broad categories:

1.3.1.1 *Air*

Compressed air is pumped either down the bore hole's annular space or down the drill string itself.

1.3.1.2 *Air/water*

The same as above, with water added to increase viscosity, flush the hole, provide more cooling, and/or to control dust.

1.3.1.3 *Air/polymer*

A specially formulated chemical, most often referred to as a type of polymer, is added to the water & air mixture to create specific conditions. A foaming agent is a good example of a polymer.

1.3.1.4 *Water*

Water by itself is sometimes used. In offshore drilling sea water is typically used while drilling the top section of the hole.

1.3.1.5 *Water-based mud (WBM)*

Most basic water-based mud systems begin with water, then clays and other chemicals are incorporated into the water to create a homogeneous blend resembling something between chocolate milk and a malt (depending on viscosity). The clay is usually a combination of native clays that are suspended in the fluid while drilling, or specific types of clay that are processed and sold as additives for the WBM system.

The most common of these is bentonite, frequently referred to in the oilfield as "gel". Gel likely makes reference to the fact that while the fluid is being pumped, it can be very thin and free-flowing (like chocolate milk), though when pumping is stopped, the static fluid builds a "gel" structure that resists flow. When an adequate pumping force is applied to "break the gel", flow resumes and the fluid returns to its previously free-flowing state. Many other chemicals (e.g. potassium formate) are added to a WBM system to achieve various effects, including: viscosity control, shale stability, enhance drilling rate of penetration, cooling and lubricating of equipment.

1.3.1.6 *Oil-based mud (OBM)*

Oil-based mud is a mud where the base fluid is a petroleum product such as diesel fuel. Oil-based muds are used for many reasons, including increased lubricity, enhanced shale inhibition, and greater cleaning abilities with less viscosity. Oil-based muds also withstand greater heat without breaking down. The use of oil-based muds has special considerations, including cost, environmental considerations such as disposal of cuttings in an appropriate place, and the exploratory disadvantages of using oil-based mud, especially in wildcat wells. Using an oil-based mud interferes with the geochemical analysis of cuttings and cores and with the determination of API gravity because the base fluid cannot be distinguished from oil returned from the formation



Figure 1 Oil Based Mud Mixing

1.3.1.7 Synthetic-based fluid (SBM)

(Otherwise known as Low Toxicity Oil Based Mud or LTOBM), Synthetic-based fluid is a mud where the base fluid is a synthetic oil. This is most often used on offshore rigs because it has the properties of an oil-based mud, but the toxicity of the fluid fumes are much less than an oil-based fluid. This is important when men work with the fluid in an enclosed space such as an offshore drilling rig. Synthetic-based fluid poses the same environmental and analysis problems as oil-based fluid.

On a drilling rig, mud is pumped from the mud pits through the drill string where it sprays out of nozzles on the drill bit, cleaning and cooling the drill bit in the process. The mud then carries the crushed or cut rock "cuttings" up the annular space "annulus" between the drill string and the sides of the hole being drilled, up through the surface casing, where it emerges back at the surface. Cuttings are then filtered out with either a shale shaker, or the newer shale conveyor technology, and the mud returns to the mud pits. The mud pits let the drilled "fines" settle; the pits are also where the fluid is treated by adding chemicals and other substances.



Figure 2 Waste Pit

1.3.2 Fluid Pit

The returning mud can contain natural gases or other flammable materials which will collect in and around the shale shaker / conveyor area or in other work areas. Because of the risk of a fire or an explosion if they ignite, special monitoring sensors and explosion-proof certified equipment is commonly installed, and workers are advised to take safety precautions. The mud is then pumped back down the hole and further re-circulated. After testing, the mud is treated periodically in the mud pits to ensure properties which optimize and improve drilling efficiency, borehole stability, and other requirements listed below.



Figure 3 Fly Ash Absorbent for Fluids in Mud Pits

1.3.3 Functions of Drilling Fluids

1.3.3.1 Remove Cuttings from well

Drilling fluid carries the rock excavated by the drill bit up to the surface. Its ability to do so depends on cutting size, shape, and density, and speed of fluid traveling up the well (annular velocity).

These considerations are analogous to the ability of a stream to carry sediment; large sand grains in a slow-moving stream settle to the stream bed, while small sand grains in a fast-moving stream are carried along with the water.

The mud viscosity is another important property, as cuttings will settle to the bottom of the well if the viscosity is too low.

Other properties include:

- Most drilling muds are thixotropic (viscosity increase during static conditions). This characteristic keeps the cuttings suspended when the mud is not flowing during, for example, maintenance.
- Fluids that have shear thinning and elevated viscosities are efficient for hole cleaning.
- Higher annular velocity improves cutting transport. Transport ratio (transport velocity / lowest annular velocity) should be at least 50%.
- High density fluids may clean hole adequately even with lower annular velocities (by increasing the buoyancy force acting on cuttings). But may have a negative impact if mud weight is in excess of that needed to balance the pressure of surrounding rock (formation pressure), so mud weight is not usually increased for hole cleaning purposes.
- Higher rotary drill-string speeds introduce a circular component to annular flow path. This helical flow around the drill-string causes drill cuttings near the wall, where poor hole cleaning conditions occur, to move into higher transport regions of the annulus. Increased rotation is the one of the best methods for increasing hole cleaning in high angle and horizontal wells.



Figure 4 Cutting transport to shale shaker

1.3.3.2 Suspend and Release Cuttings

- Must suspend drill cuttings, weight materials and additives under a wide range of conditions.
- Drill cuttings that settle can cause bridges and fill, which can cause stuck-pipe and lost circulation.
- Weight material that settles is referred to as sag, this causes a wide variation in the density of well fluid, this more frequently occurs in high angle and hot wells.
- High concentrations of drill solids are detrimental to: Drilling efficiency (it causes increased mud weight and viscosity, which in turn increases maintenance costs and increased dilution).
- Rate of Penetration (ROP) increases horsepower required to circulate.
- Mud properties that are suspended must be balanced with properties in cutting removal by solids control equipment.

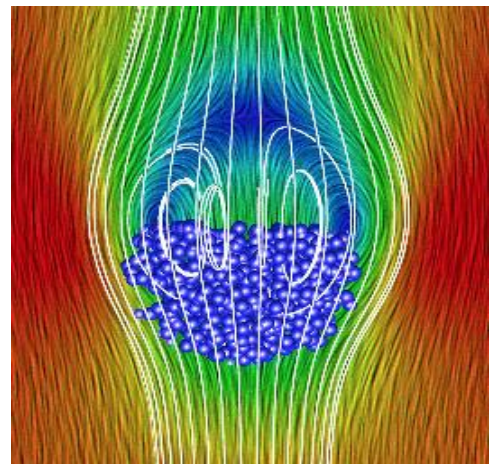

Figure 5 Transport velocity = Annular velocity-Slip velocity

- For effective solids controls, drill solids must be removed from mud on the first circulation from the well. If re-circulated, cuttings break into smaller pieces and are more difficult to remove.
- Conduct a test to compare the sand content of mud at flow line and suction pit (to determine whether cuttings are being removed)



Figure 6 Solids removal at the shale shaker

1.3.3.3 Control formation pressures

- If formation pressure increases, mud density should also be increased to balance pressure and keep the wellbore stable. The most common weighting material is barite. Unbalanced formation pressures will cause an unexpected influx (also known as a kick) of formation fluids in the wellbore possibly leading to a blowout from pressured formation fluids.
- Hydrostatic pressure = density of drilling fluid × true vertical depth × acceleration of gravity. If hydrostatic pressure is greater than or equal to formation pressure, formation fluid will not flow into the wellbore.
- Well control means no uncontrollable flow of formation fluids into the wellbore.
- Hydrostatic pressure also controls the stresses caused by tectonic forces, these may make wellbores unstable even when formation fluid pressure is balanced.
- If formation pressure is subnormal, air, gas, mist, stiff foam, or low-density mud (oil base) can be used.
- In practice, mud density should be limited to the minimum necessary for well control and wellbore stability. If too great it may fracture the formation.



Figure 7 Blowout at an Offshore Rig

1.3.3.4 *Seal permeable formations*

- Mud column pressure must exceed formation pressure, in this condition mud filtrate invades the formation, and a filter cake of mud is deposited on the wellbore wall.
- Mud is designed to deposit thin, low permeability filter cake to limit the invasion.
- Problems occur if a thick filter cake is formed, tight hole conditions, poor log quality, stuck pipe, lost circulation and formation damage.
- In highly permeable formations with large bore throats, whole mud may invade the formation, depending on mud solids size; Use bridging agents to block large opening, then mud solids can form seal.
- For effectiveness, bridging agents must be over the half size of pore spaces / fractures.
- Bridging agents (e.g. calcium carbonate, ground cellulose).
- Depending on the mud system in use, a number of additives can improve the filter cake (e.g. bentonite, natural & synthetic polymer, asphalt and gilsonite).

1.3.3.5 *Maintain wellbore stability*

- Chemical composition and mud properties must combine to provide a stable wellbore. Weight of the mud must be within the necessary range to balance the mechanical forces.
- Wellbore instability = sloughing formations, which can cause tight hole conditions, bridges and fill on trips (same symptoms indicate hole cleaning problems).
- Wellbore stability = hole maintains size and cylindrical shape.
- If the hole is enlarged, it becomes weak and difficult to stabilize, resulting in problems such as low annular velocities, poor hole cleaning, solids loading and poor formation evaluation
- In sand and sandstones formations, hole enlargement can be accomplished by mechanical actions (hydraulic forces & nozzles velocities). Formation damage is reduced by conservative hydraulics system. A good quality filter cake containing bentonite is known to limit bore hole enlargement.
- In shales, mud weight is usually sufficient to balance formation stress, as these wells are usually stable. With water base mud, chemical differences can cause interactions between mud & shale that lead to softening of the native rock. Highly fractured, dry, brittle shales can be extremely unstable leading to mechanical problems.
- Various chemical inhibitors can control mud / shale interactions (calcium, potassium, salt, polymers, asphalt, glycols and oil – best for water sensitive formations)
- Oil (and synthetic oil) based drilling fluids are used to drill most water sensitive Shales in areas with difficult drilling conditions.
- To add inhibition, emulsified brine phase (calcium chloride) drilling fluids are used to reduce water activity and creates osmotic forces to prevent adsorption of water by Shales.

1.3.3.6 *Minimizing formation damage*

- Skin damage or any reduction in natural formation porosity and permeability (washout) constitutes formation damage
- skin damage is the accumulation of residuals on the perforations and that causes a pressure drop through them.
- Most common damage; Mud or drill solids invade the formation matrix, reducing porosity and causing skin effect Swelling of formation clays within the reservoir, reduced permeability.
- Precipitation of solids due to mixing of mud filtrate and formations fluids resulting in the precipitation of insoluble salts.
- Mud filtrate and formation fluids form an emulsion, reducing reservoir porosity
- Specially designed drill-in fluids or workover and completion fluids minimize formation damage.

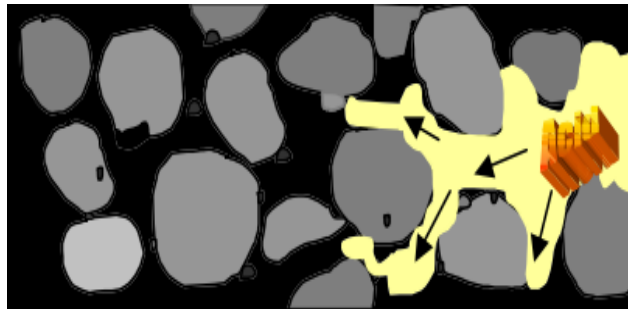

Figure 8 Proper drilling fluid selection reduces formation damage

1.3.3.7 *Cool, lubricate, and support the bit and drilling assembly*

- Heat is generated from mechanical and hydraulic forces at the bit and when the drill string rotates and rubs against casing and wellbore.
- Cool and transfer heat away from source and lower to temperature than bottom hole.
- If not, the bit, drill string and mud motors would fail more rapidly.
- Lubrication based on the coefficient of friction. "Coefficient of friction" is how much friction on side of wellbore and collar size or drill pipe size to pull stuck pipe Oil- and synthetic- based mud generally lubricate better than water-based mud (but the latter can be improved by the addition of lubricants).
- Amount of lubrication provided by drilling fluid depends on type & quantity of drill solids and weight materials + chemical composition of system.
- Poor lubrication causes high torque and drag, heat checking of the drill string, but these problems are also caused by key seating, poor hole cleaning and incorrect bottom hole assemblies design.

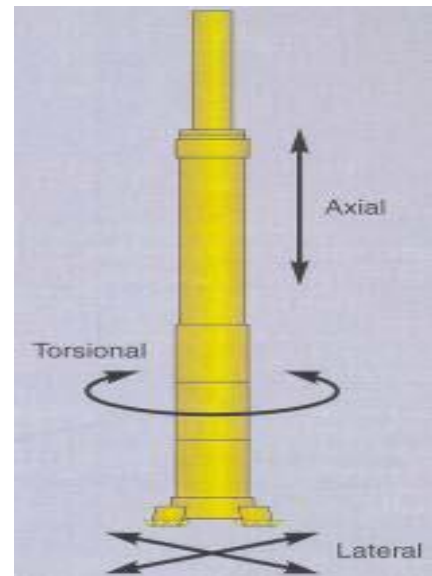

Figure 9 Drill string Rotation causes friction and heat

1.3.3.8 Provide Buoyancy for the Drill String

- Drilling fluids also support portion of drill-string or casing through buoyancy.
- If a drill string, liner or casing string is suspended in drilling fluid, it is buoyed by a force equal to the weight of the mud displaced, thereby reducing hook load on the derrick.
- When running long, heavy string or casing, buoyancy makes it possible to run casing strings whose weight exceed a rig's hook load capacity.

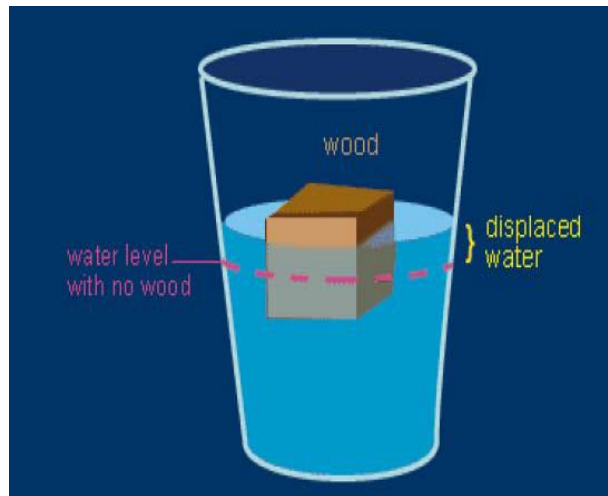

Figure 10 Buoyancy provides support for drill string

1.3.3.9 Transmit hydraulic energy to tools and bit

- Hydraulic energy provides power to mud motor for bit rotation and for MWD (measurement while drilling) and LWD (logging while drilling) tools. Hydraulic programs base on bit nozzles sizing for available mud pump horsepower to optimize jet impact at bottom well.
- Limited to:
 - Pump horsepower
 - Pressure loss inside drill string
 - Maximum allowable surface pressure
 - Optimum flow rate
 - Drill string pressure losses higher in fluids higher densities, plastic viscosities and solids.
 - Low solids, shear thinning drilling fluids such as polymer fluids, more efficient in transmit hydraulic energy.
 - Depth can be extended by controlling mud properties.
 - Transfer information from MWD & LWD to surface by pressure pulse.

1.3.3.10 *Ensure adequate formation evaluation*

- Chemical and physical mud properties and wellbore conditions after drilling affect formation evaluation.
- Mud loggers examine cuttings for mineral composition, visual sign of hydrocarbons and recorded mud logs of lithology, ROP, gas detection or geological parameters.
- Wireline logging measure – electrical, sonic, nuclear and magnetic resonance.
- Potential productive zones are isolated and formation testing, and drill stem testing are performed.
- Mud helps not to disperse cuttings and also improve cutting transport for mud loggers determine the depth of the cuttings originated.
- Oil-based mud, lubricants, asphalts will mask hydrocarbon indications.

So, mud for drilling core is selected based on type of evaluation to be performed (many coring operations specify a blend mud with minimum of additives).

1.3.3.11 *Control corrosion (in acceptable level)*

- Drill-string and casing in continuous contact with drilling fluid may cause a form of corrosion.
- Dissolved gases (oxygen, carbon dioxide, hydrogen sulfide) cause serious corrosion problems;
- Cause rapid, catastrophic failure
- May be deadly to humans after a short period of time
- Low pH (acidic) aggravates corrosion, so use corrosion coupons clarification needed to monitor corrosion type, rates and to tell correct chemical inhibitor is used in correct amount.
- Mud aeration, foaming and other O₂ trapped conditions cause corrosion damage in short period time.
- When drilling in high H₂S, elevated the pH fluids + sulfide scavenging chemical (zinc).

1.3.3.12 *Facilitate cementing and completion*

- Cementing is critical to effective zone and well completion.
- During casing run, mud must remain fluid and minimize pressure surges, so fracture induced lost circulation does not occur.
- Temperature of water used for cement must be within tolerance of cementers performing task, usually 70 degrees, most notably in winter conditions.
- Mud should have thin, slick filter cake, with minimal solids in filter cake, wellbore with minimal cuttings, caving or bridges will prevent a good casing run to bottom. Circulate well bore until clean.
- To cementing and completion operation properly, mud displaced by flushes and cement for effectiveness.
- Hole near gauges, use proper hole cleaning techniques, pumping sweeps at TD, and perform wiper trip to shoe.
- Mud low viscosity, mud parameters should be tolerant of formations being drilled, and drilling fluid composition, turbulent flow - low viscosity high pump rate, laminar flow - high viscosity, high pump rate.

1.3.3.13 *Minimize impact on environment*

- Unlined drilling fluid sumps were common place before the environmental consequences were recognized.
- Mud is, in varying degrees, toxic. It is also difficult and expensive to dispose of it in an environmentally friendly manner.
- Water based drilling fluid has very little toxicity, made from water, bentonite and barite, all clay from mining operations, usually found in Wyoming and in Lunde, Telemark.
- Most common chemicals added to OBM Muds:
 - Barite:
 - Bentonite:
 - Diesel:
 - Emulsifiers:
 - Water:

1.3.4 Factors Influencing Drilling Fluid Performance

Several factors affecting drilling fluid performance are:

- The change of drilling fluid viscosity
- The change of drilling fluid density
- The change of mud pH
- Corrosion or fatigue of the drill string
- Thermal stability of the drilling fluid
- Differential sticking

1.3.5 Drilling Fluid Classification

1.3.5.1 *Dispersed systems*

- Freshwater mud: Low pH mud (7.0–9.5) that includes spud, bentonite, natural, phosphate treated muds, organic mud and organic colloid treated mud. high pH mud example alkaline tannate treated muds are above 9.5 in pH.
- Water based drilling mud that represses hydration and dispersion of clay – There are 4 types: high pH lime muds, low pH gypsum, seawater and saturated salt water muds.

1.3.5.2 *Non-dispersed systems*

- Low solids mud: These muds contain less than 3–6% solids by volume and weight less than 9.5 lbs/gal. Most muds of this type are water-based with varying quantities of bentonite and a polymer.
- Emulsions: The two types used are oil in water (oil emulsion muds) and water in oil (invert oil emulsion muds).

1.3.5.3 *Oil based mud*

- Oil based muds contain oil as the continuous phase and water as a contaminant, and not an element in the design of the mud. They typically contain less than 5% (by volume) water. Oil-based muds are usually a mixture of diesel fuel and asphalt,

however can be based on produced crude oil and mud.

1.4 DRILL-IN FLUIDS

A wide variety of options exists for choosing drill-in fluids. The selection of the most appropriate drill-in fluid depends not only on potential formation damage mechanisms, but also on the type of formation to be drilled and the completion method to be used. Temperature, density and known drilling problems also must be considered. Listed below are some potential drill-in fluid options and the primary application for each.

1.4.1 Clear Fluids with Viscous Sweeps

Clear water or brine drill-in fluids can be used for mechanically competent formations that are not adversely affected by the intrusion of large volumes of fluid into the reservoir. These non-viscosified fluids are often used in fractured limestones and dolomites, as well as in reef formations; fractured sandstones; and clean, low-permeability sandstones.

1.4.2 Hydroxy Ethyl Cellulose Fluids

Hydroxy-ethyl-cellulose base (HEC) fluids can be used under conditions like those in which the clear fluids discussed above are, i.e., in competent formations. HEC provides carrying capacity but has minimal gel structure and poor suspension characteristics. The low-shear rheology and suspension characteristics can be enhanced by adding xanthan gum.

1.4.3 Sized Salt Systems

Sized-salt (NaCl) systems are used to drill unconsolidated sand reservoirs. These systems are based on a saturated salt brine using xanthan gum for viscosity and a combination of starch and sized-salt particles for fluid-loss control. The elevated starch concentration and salt bridging agents provide excellent fluid-loss control. To maintain bridging, the system must be saturated with salt. These systems have a narrow density range from 10 to 12 lb/gal. Sized-salt systems generally provide acceptable wellbore and temperature stability.

These systems can be used with any type of completion assembly. They are usually cleaned up with a two-step procedure:

- An acid soak to destroy the polymers, followed by,
- An unsaturated water wash to remove the salt particles.

1.4.4 VERSADRILT/VERSACLEANT/VERSAPOR™

- These are oil-base systems that can be formulated to have non-damaging characteristics for drill-in applications. VERSADRIL has a diesel oil base. VERSACLEAN has a mineral oil base.
- VERSAPORT is formulated to have an elevated LSRV using VERSAMODE or VERSA-HRPT (in either diesel or mineral oil) for enhanced hole cleaning in high-angle wells.
- An important application for oil-base, drill-in fluids is in very dirty sands. If such sands are drilled with water-base fluids, they develop a water block or are damaged by clay swelling. Such conditions do not develop in oil-base filtrate.
- Oil-base fluids also provide significantly better shale stability for production intervals where shale sections are interbedded with the producing formation. Oil-base fluids have thin filter cakes, excellent inhibition and good lubricity. These qualities simplify many aspects of particularly problematic horizontal wells. For example, the improved lubricity of oil-base fluids allows the drilling of a well with complex hole geometry or an extended horizontal interval. Such wells cannot be drilled with a water-base fluid.
- The oil/water ratios for these fluids can vary from 100/0 to 50/50. Generally, acid-soluble sized calcium carbonate, such as SAFE-CARB, is used as the weighting agent for wells completed with prepacked screens.
- Calcium carbonate drill-in fluids can weigh up to 12.5 lb/gal. For higher densities, barite, hematite or alternative weight materials must be used (for special formations and applications) and usually the well must be completed with an assembly that will allow the weight material to be produced back through the slotted liner or wire-wrapped screen. A clean completion fluid displacement is critical to effective removal of filter cake produced by an oil-base fluid. Surfactants and mutual solvents are required to reverse the wettability of the filter cake so that it can be dissolved by acid. In addition, the type of acid stimulation should be designed to dissolve the filter cake uniformly.

1.4.5 NOVADRILT/NOVAPLUST/NOVATEC™

- These are synthetic-base mud systems that can be formulated with nondamaging characteristics.
- Synthetic drill-in fluids provide advantages like those provided by the oil-base fluids discussed above. They are, however, significantly more expensive than comparable oil-base systems. These fluids are approved for offshore cuttings discharge in many locations around the world — contingent upon local regulations.
- The synthetic fluids find application in environmentally sensitive areas, particularly where the production zone is an easily damaged sandstone with high clay content. The filtrate from synthetic-base fluids generally does not disturb interstitial clays. Also, synthetic base fluids provide significantly better shale stability for production intervals where shale sections are interbedded with the producing formation.
- The synthetic/water ratios for these fluids can vary from 100/0 to 50/50. Generally, acid-soluble sized calcium carbonate, such as SAFE-CARB, is used as the weighting agent for wells completed with prepacked screens. These calcium carbonate drill-in fluids can weigh up to 12.5 lb/gal. For higher densities, barite, hematite or alternative weight materials must be used (for special formations and applications) and usually the well must be completed with an assembly that will allow the weight material to be produced back through the slotted liner or wire-wrapped screen. As with oil-base fluids, clean completion fluid displacement is critical to the effective removal of filter cake formed by synthetic fluids. Too, surfactants and mutual solvents are required to reverse the wettability of the filter cake so that it can be dissolved by acid. In addition, uniform dissolution of the filter cake depends on the proper design of the acid stimulation.

1.5 COMPLETION AND WORKOVER FLUIDS

Completion and workover fluids are specialized fluids used during well completion operations and remedial workover procedures. These fluids must control not only subsurface pressure with density, but also must minimize formation damage during completion and workover operations.

The use of fluids that cause minimal formation damage can result in dramatically improved production. Most reservoirs are sensitive to any fluids other than those contained in them naturally. Therefore, any fluid introduced that is chemically and/or physically different from natural formation fluids may cause some reservoir damage. All wells are susceptible to formation damage to some degree, from a slight reduction in the production rate to complete plugging of specific zones. The objective is to use a fluid that causes the least possible damage to the producing zone, because the potential for permanent damage is greater during completion and workover operations than it is during drilling.

Completion fluids are placed across the chosen pay zone after the well has been drilled but prior to putting it on production. Workover fluids are used during remedial work in producing wells, usually as an attempt to enhance or prolong the economic life of the well.

Functions of completion and workover fluids are to:

- Control subsurface pressures.
- Minimize formation damage.
- Maintain wellbore stability.
- Control fluid losses to the formation.
- Transport solids.
- Maintain stable fluid properties.

The types of completion and workover fluids can be categorized into:

- Clear, solids-free brines.
- Polymer-viscosified brines with bridging/weighting agents.
- Other fluids: oil-base, water-base, converted muds, foam.

Clear, solids-free brines are the most commonly used fluids in completion and workover operations. Brines also are viscosified with polymers and may incorporate solids that can be dissolved later, such as acid-soluble calcium carbonate (SAFE-CARBE) or sized sodium chloride salt, for increased density or bridging to limit leak-off (fluid losses and invasion of the reservoir). Chloride and bromide-base inorganic brines are the most widely used completion and workover brines. Recently, formate-base organic brines have been introduced as alternatives. Other fluid options are generally related to more conventional muds, even though they, too, may be formulated with acid-soluble bridging/ weighting agents.

The primary selection criterion for an appropriate completion or workover fluid is density. Brine temperature should always be measured and recorded when checking fluid density, and the density corrected to the standard reporting temperature of 70°F.

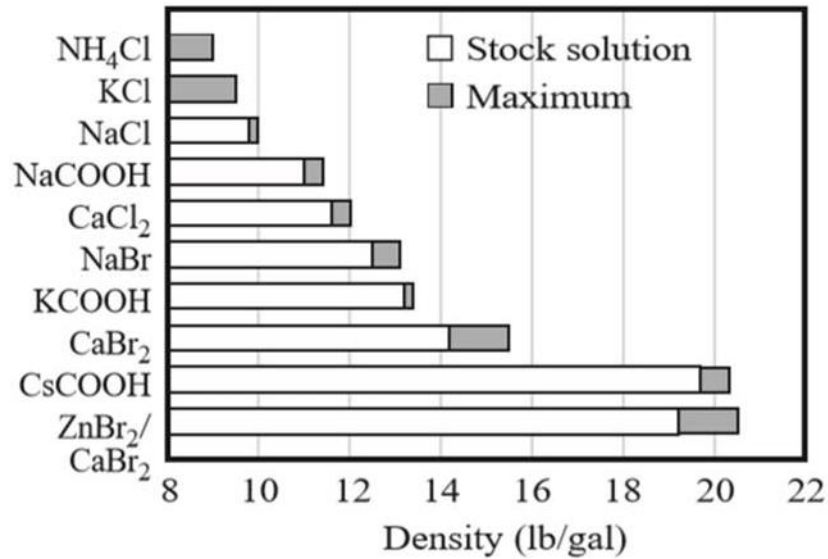

NOTE: High temperature causes thermal expansion of brines, which causes a reduction in density and hydrostatic pressure. Both temperature and pressure effects should be considered when selecting a brine with density appropriate for completion and workover fluids.

A related fluid category is drill-in fluids, which are fluids used for drilling and completing special reservoir sections such as horizontal wells. Drill-in fluids must provide the multifunctional requirements of drilling fluids; however, they must also minimize formation damage and be compatible with the formation and completion methods used. Packer fluids are placed in the annulus of a well and remain above the packer for the life of the well. Packer fluids are usually modified completion brines or conditioned drilling muds. They are selected and formulated for a several reasons:

- (1) to be non-corrosive to casing or production tubulars,
- (2) so that weight materials (or other solids) do not settle out on top of the packer, and
- (3) so that they remain stable and do not solidify over long periods of time.

2 BASIC MUD LOGGING

2.1 OBJECTIVES

After studying this section, the trainees should be able to perform the following:

- Describe the function of mud logging operation
- Describe the function of all components of the Rig Up equipment.
- Describe the preventive maintenance
- Describe the operational procedures
- Describe mud logging operator's general safety precautions and emergency response procedures

2.2 OUTCOMES

Upon completing their training, the participants should be able to:

- Perform the collection of cuttings samples
- Wash and screen samples
- Assist in core recovery and packaging as required
- Assist in performing regular and frequent calibration checks of instruments
- Assist in routine maintenance of sensors and other equipment
- Assist with rig-up procedures
- Demonstrate knowledge of all mud logging services and related products
- Assist in mud logging operation (engine, drive train, and hydraulics), minor unit maintenance, and process documentation

2.3 OVERVIEW

Mud logging is a service that qualitatively and quantitatively obtains data from, and makes observations of, drilled rocks, drilling fluids and drilling parameters in order to formulate and display concepts of the optional, in situ characteristics of formations rocks with the primary goal of delineating hydrocarbon "shows" worthy of testing. The mud logging unit is the information center on the rig site to serve both exploration and drilling.

General Purposes:

- Optimized drilling efficiency.
- Comprehensive formation evaluation.
- Improved well site safety

2.4 MUD LOGGING UNIT

The mud unit is located very close to the rig floor. A number of cables extends from the unit to a number of sensors installed at different locations on the drilling rig. these sensors are used to measure many important variables or parameters of the rig operations:

- The essential role that the unit plays on board, is the collection of the rock cuttings which is geologically described, examined for any oil shows and then packed according to the exploration company requirements.
- The mud logging unit is responsible for the hydrocarbon gas monitoring while drilling. These gases are detected as a total value then are analyzed to their components.
- The mud logging unit is responsible for the detection of the Hydrogen sulfide (H₂S) gas while drilling which is very dangerous if it is not detected in the very early stage.
- The mud logging unit is responsible for the monitoring of the drill fluid volume second by second and to immediately inform the personnel in charge about any change in that volume (Loss/Gain).
- The mud logging unit is responsible for the generation of mud logs and graphs during the drilling of the well, acquisition of the data and producing a final well report.
- The mud logging unit is responsible for the monitoring of the drilling parameters such as : WOB, RPM, TRQ. etc., And to inform the personnel in charge about any anomalies or figures that could be out of the set ranges.
- The mud logging unit is responsible for confirming with the driller about any drilling breaks.
- The mud logging unit is responsible for monitoring the trips and updating a trip sheet at a five-stand basis. This trip monitoring sheet includes the calculated/observed hole fill-up or string displacement along with remarks on string overpull, tight spots and running speed.
- The mud logging unit extends its service to the detection and evaluation of the formation pressure, the hydraulics optimization and the well control.
- The mud logging unit is considered the information center of the rig site as the unit participates in the monitoring of each and very rig operation.

2.4.1 Types of Mud Logging Units

Mud logging units can be classified into two main categories depending on the method of data acquisition and processing: -

1. Off-line mud logging units.
2. On-line mud logging units.

2.4.1.1 *Mud Logging Off-line service features*

The off-line mudlogging unit includes a number of separate panels. Each panel works independently and is responsible for measuring a definite parameter. There is no communication between these panels. No automatic calculations can be done and no Data storage. All panel calibrations are done manually.



Figure 11 Mud logging unit

2.4.1.2 *Mud Logging On-line service features*

- 1- Minimum human interference
- 2- Fully computerized service with powerful software
- 3- Best possible equipment design in the industry
- 4- Intrinsic safety

2.5 **DUTIES & RESPONSIBILITIES**

2.5.1 Mud Logging Unit Captain

The Unit captain is the senior mud logging engineer on the location. He has primary responsibility for the maintenance, management and provision of service by the logging unit, its equipment and personnel to the client. The unit captain is the representative of companies' logging systems at the well site. He is responsible for the maintenance and correct operation of the equipment supplied to provide the service. He is responsible for the collation and presentation of the information monitored in accordance with company standard procedures and customer requirements to ensure a high quality of service.

2.5.2 Mud Logger

He is responsible for the maintenance and correct operation of the equipment supplied to provide the service. He is responsible for the collation and presentation of the information monitored in accordance with company standard procedures and customer requirements to ensure a high-quality service.

2.6 **THE MUD LOGGING THEORY & LAG**

The mud logging theory is based on the mud cycle principal. The mud is sucked from the pits (Active Pit) and pumped via the drilling string down to the hole bottom. The mud is then bumped against gravity through the annulus up to the shakers. The time necessary to get the drilled samples to the surface is exactly the time required to pump the mud volume through this passage. This is calculated and is known as Lag time or lag strokes.

The calculation and practical application of the lag is of primary importance in mud logging and relates to the all data that the mud transmits to the surface.

The mud actually carries the information that we require from the bit depth to the surface and the time that the mud takes to get from the bit to surface is the basic calculation made. The factors that affect the time or lag of the mud are the flow rate of the mud, the configuration of the well; the sizes and depths of the different hole sections and the drill string sections' dimensions.

2.6.1 Lag Definitions

- Lag time is the time the mud takes to travel inside the hole between two specified depth points.
- The time taken between the surface to the bottom of the hole is called "lag down" or "Lag in".
- The time taken between the bottom of the hole to the surface is called "lag-up" or "bottoms up".
- The surface to surface time is called "Complete cycle" or In/Out time.



Figure 12 Mud logging unit

It is more practical to calculate lag in terms of pump strokes as the flow rate is not necessarily constant. To calculate the lag the hole dimensions must be known as well as the drill string dimension. Most holes have at least two section of different diameters and towards the end of the well may will have more (riser, casing liner, and open hole). Added to this is the fact that the drill string will usually have sections of different diameters (drill pipe, heavyweight drill pipe and drill collars, etc.)

Two techniques may be applied to calculating the annular volume, these are: -

In the first method, the lengths and the dimensions of each section of the annulus are determined, the volumes are calculated and totalized. Then the lag equations are applied to determine the equivalent times and strokes.

The second method involves calculating the volume of the hole and the volume of the drill string (metal and internal capacity) and then subtracting the values from each other to determine the lag time and strokes for the whole well. The first method is the one preferred because it informs the logger of the exact nature of the various annular sections and their individual volumes. This also helps in the calculations of the annular pressure drops.

With the use of the off-line mudlogging units the increase with depth should be calculated for a given length of hole by calculating the annular volume of the hole (bit diameter) filled with drill pipe. This should be added to the total annular volume to update the lag calculation to the current depth. For the On-Line logging unit this is automatically calculated and added as the depth increases.

The lag, as already mentioned, is most accurately counted in pump strokes. The annulus volume divided by the pump output per stroke will give the number of strokes needed to displace the mud up the annulus.

2.6.2 Lag Equations

A. Coverting Barrels > Gallons:

$$\text{Gallons (gal)} = \text{Barrels} * 42$$

B. Coverting Gallons > Barrels:

$$\text{Barrels (bbl)} = \text{Gallons}/42$$

C. Calculating Pipe volume:

$$\text{Pipe volume (bbl)} = \frac{(\text{Pipe or Collar ID}^2)}{1029.4} * \text{Length}$$

D. Calculating Annular volume:

$$\text{Annular volume (bbl)} = \frac{(\text{Hole or Casing ID}^2 - \text{Pipe or collar OD}^2)}{1029.4} * \text{Length}$$

E. Calculating Lag-in strokes:

$$\text{Lag - in strokes} = \frac{\text{Annular Volume (bbl)}}{\text{Pump output } (\frac{\text{bbl}}{\text{stroke}})}$$

F. Calculating Lag-in minutes:

$$\text{Lag - in minutes} = \frac{\text{Lag - in strokes}}{\text{Pump Rate (spm)}}$$

2.6.3 Lag Correction

Using the correct lag is vital to the geologist so that samples and hydrocarbon shows are described at the correct depth from which they came.

If the open hole section is in gauge; then the actual lag will be the same as the calculated lag. This is rarely the case in practice as most of the salt sections and some shale sequences tend to become washed out. Therefore, carbide lag checks should be run frequently to determine the actual lag.

The procedure for carbide lag is to wrap a quantity of fine carbide in paper towel and place it inside the pipe at a connection. The action of water on the carbide will release acetylene gas which on circulating out of the system will be detected by the gas detector. Since the gas must travel down the pipe to the bit and then to the surface, it is necessary to calculate the following:

1. The number of strokes from the surface to the bit inside the pipe.
2. The total number of strokes from starting up the pump until the gas arrives at the surface.
3. Subtract 1 from 2

The resulting number of strokes is the actual lag time. From this it is possible to estimate the amount of washout in the hole.

Apart from making regular carbide lag checks, a check should be made if for any reason the lag becomes suspect; for example, the cuttings do not correspond with the drill rates from which they are supposed to come, or connection gas does not appear at the correct time.

If for some reason, carbide is not available a perfectly good lag check can be obtained by using rice or lentil. The main disadvantage of this is that it is necessary to stay and watch the shakers when the rice is due appear, or it could well be missed. Rates of travel up the annulus differ for gas and cuttings as the cuttings will tend to slip back due to slip velocity. Slip velocity depends on the cuttings size density, the mud properties flow rate and hole size.

2.7 TRIP MONITORING

Trip monitoring is considered one of the most important of the duties and responsibilities of the mud logger. The mud logger should not feel relaxed during trip times as statistics indicate that the most of the serious well problems and disasters have happened while tripping.

2.7.1 Trip-In Monitoring Procedures

1. Calculate metal displacement for each string section.
2. Check which tank should receive the displaced mud.
3. If displaced mud will return to active pit, check if the surface tanks (sand trap) are filled: -
 - a) If they are filled, mud should return to active pit once tripping-in starts.
 - b) If they are not filled, mud cannot be monitored in the active pit until surface tanks get filled.
Therefore, you must either inform driller and Co. Man that they should fill the surface pits prior to

tripping-in; or start the monitoring once the surface tanks get filled and the displaced mud starts returning to active pit. In this case, estimate how many bbls would be required to fill surface tanks and how many stands should run-in to displace this required volume. (Note that surface tanks are monitored manually.

4. If displaced mud will return to active pit, check if the surface tanks (sand trap) are filled: -

P V T	TREND	INTERPRETATION	ACTION
Steady		Mud losses due to surge action	Inform driller and Co. Man.
Showing increase	Increase is equal to the metal displacement	Everything is OK	No action.
	Increase is less than the metal displacement	Partial mud loss	Inform driller and Co. Man.
	Increase is more than the metal displacement	1. Well flowing	Inform driller and Co. Man.
	the metal displacement	. Jet plugging (pipe is not filled completely)	Ask driller to fill the pipe.

Stands (94 ft.)	Displacement (BBL)		Time	Measured Trend Differences (BBL)		
	Calculate d (Cum.)	Actual (Cum.)		Calculated	Actual	Trend Change
PIH			0600			
1 - 4 DC	13.2	13.0	0620	13.2	13	-0.2
5 - 8	26.4	26.0	0640	13.2	13	-0.2
9 - 11	36.3	35.5	0700	9.9	9.5	-0.4
11 - 20	43.0	41.8	0720	6.7	6.3	-0.4
21 - 30	49.7	47.8	0740	6.7	6.0	-0.7
31 - 40	56.4	52.8	0700	6.7	5.0	-1.7
41 - 50	63.1	52.8	0720	6.7	4.0	-2.7

What would a trip schedule tell you when running pipe in the hole? By monitoring the trip schedule while RIH, the mud displacement schedule will dictate if hole is standing up with the added pressure (surge caused by lowering pipe).

If a logger looks at only volume (actual vs. calculated), everything might look good after POH with 90 stands. However, the trends tell a completely different story. After pulling 40-50 stands, the logger should become suspicious of the changing trends. The well actually started coming in between 40 and 60 stands. An alert logger should closely observe the well and should have the driller returned to bottom to condition the hole. Many blowouts occur during trips because a trip schedule is not made out or is not monitored in such a way to establish trends. Trying to kill a well-off bottom leads to many associated well control problems, e.g. lost circulation, differential sticking, hole bridging etc. Side tracking and hole problems associated with unscheduled deviated holes is normally the result.

2.7.2 Trip-Out Monitoring Procedures

Failure to keep the hole full while tripping can lead to serious problems; so, it is essential to properly monitor hole filling and trip trend to make sure that hole is taking the right amount of fluid replacing the metal volume being removed. Failure to keep the hole full while tripping can be considered as the single biggest cause for blowouts.

WET STRING	DRY STRING
Hole is to be filled with mud equal to both the metal displacement and pipe capacity.	Hole is to be filled with mud equal to the metal displacement only.
2- With “Trip Tank” in use (Cont. fill): Volume shows a decreasing trend equal to the metal displacement plus pipe capacity; then it shows an increasing trend equal to pipe capacity	2- With “Trip Tank” in use:(Cont. Fill): Volume will show a continuous decreasing trend.
3-With Rig Pump in use : An increasing trend while pulling out and a decreasing trend while filling hole (metal displacement + pipe capacity).	3-With Rig Pump in use : Volume will show no change while pulling out, and a decreasing trend while filling the hole.

What would a trip schedule tell you when pulling pipe out of the hole?

If a logger looks at only volume (actual vs. calculated), everything might look good after POH with 90 stands. However, the trends tell a completely different story. After pulling 40-50 stands, the logger should become suspicious of the changing trends. The well actually started coming-in between 40 and 60 stands. An alert logger should closely observe the well and should have the driller returned to bottom to condition the hole. Many blowouts occur during trips because a trip schedule is not made out or is not monitored in such a way to establish trends. Trying to kill a well-off bottom leads to many associated well control problems, e.g. lost circulation, differential stuck, hole bridging... etc. Side tracking and hole problems associated with unscheduled deviated holes is normally the end result.

2.8 SAMPLE COLLECTION DESCRIPTION

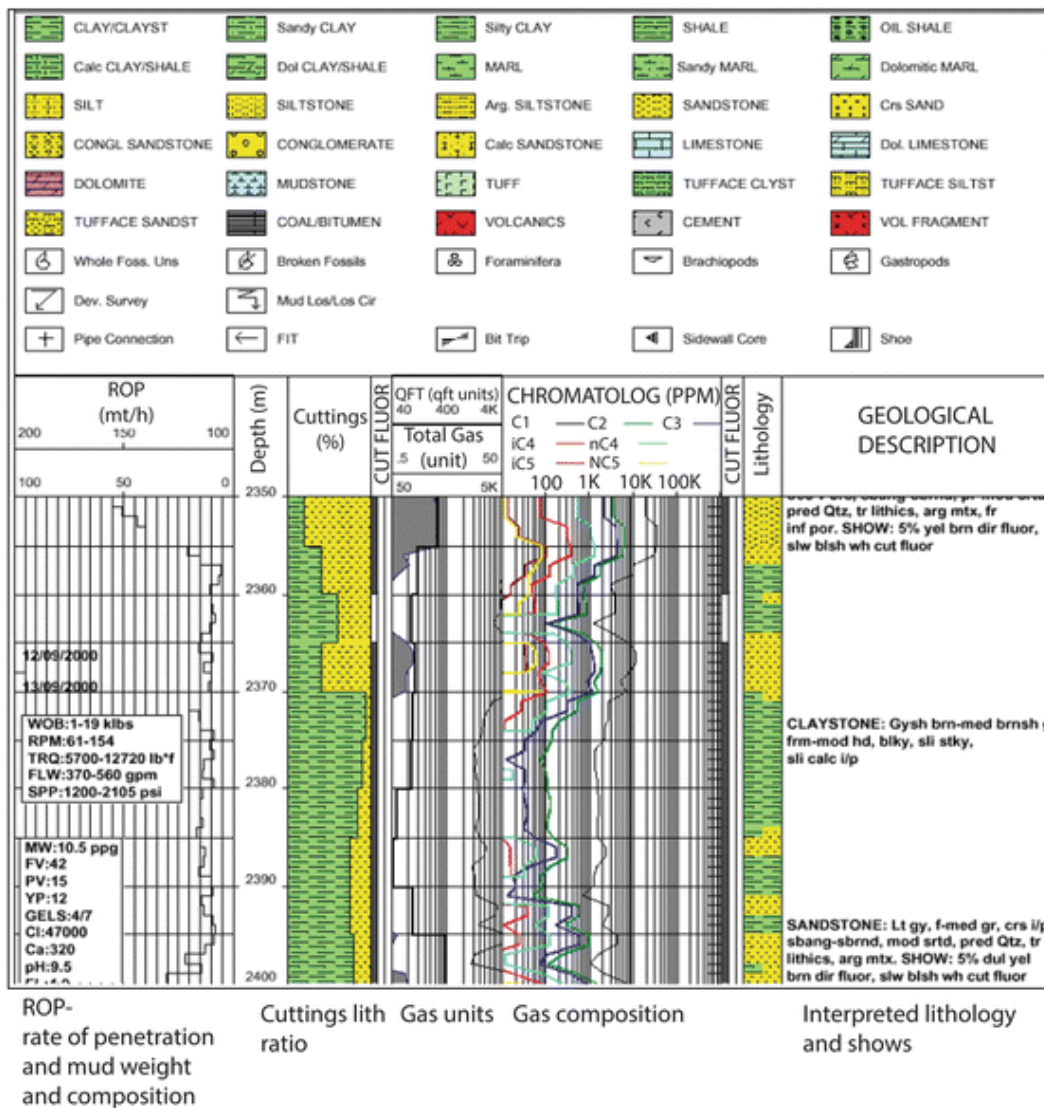

Figure 13 Sample collection description

2.8.1 Preparation for Collection of Cutting Samples

The cuttings are physical, tangible pieces of drilled rocks which required the forces of nature millions of years to lay them down and, it cost the oil companies much time and millions of dollars to recover. Drilled cuttings are often referred to as “Ditch Samples”. The expression comes from early drilling rigs that used an earthen ditch to channel mud flow at the surface.

The cuttings samples can be in a span of just a few minutes either saved for an eternity or lost forever. Aside from their immediate value, the cuttings can be saved and reevaluated in the future using knowledge and techniques that have not been discovered yet. On the other hand, cuttings falling into the reserve pit are cuttings gone forever along with the information they contain. An accurate log, a source of representative samples and close attention to making efficient use of available time are all necessary to good cuttings and mud samples collection.

2.8.2 Shaker Samples

Almost every rig has shakers with vibrating screens for separating the cuttings from the mud as they reach the surface. The shaker screen should be examined to ascertain whether the mesh size is small enough to separate small cuttings from the mud.

When the shaker screen is used a board box should be placed at the foot of the screen for the collection of the cuttings through a complete interval of the hole. What is meant here is that the sample taken would be representative of the complete interval (10 feet, 30 feet, etc.) and not just cuttings coming across the shaker at some given time representing a spot check of a couple of inches. The board box should be cleaned following each single sample gathering to avoid the mixing-up of samples of different intervals. The table below will help to determine suitable screen sizes.



Figure 14 Shaker sample

Particle type	Particle Size in millimeters	Tyler Screen Mesh Size
Silt	> 1/16	250
Very Fine Grain Sand	1/16 to 1/8	250 - 115
Fine Grain Sand	1/8 to 1/4	115 - 60
Medium Grain Sand	1/4 to 1/2	60 - 30
Coarse Grain Sand	1/2 to 1.0	30 - 16

Figure 15 Table for screen size

2.8.3 Collecting Cutting Samples

Collecting “Wet” Samples

This is a sample of unwashed cuttings that is taken for petrological examination in the oil company’s laboratories. It comprises a sample put straight into a fine mesh cloth bag, labelled and left to dry in the sun before tying into bundles and bagging up in labelled sacks or boxes. Care must be taken to adequately fill the sample sack.



Figure 16 Microscope

Washing Cuttings from Water-Base Mud

Washing and preparing the cuttings sample to be examined is probably as important as the examination itself. Here again, the technique must be adapted to the type of material and the area. In hard rock areas the cuttings are usually easily cleaned. Washing is usually just a matter of hosing the sample with jet of water to remove the film of the drilling mud from the surface of the cuttings.

Washing the cuttings from areas of recent geological ages is, however, a bit more difficult and requires the use of several precautions. As the shales present are soft and dispersible in water, the wash water will tend to wash this shale away. This should be taken into account; the mud logger should remain aware that the shale that would be washed away is a part of the sample and not a foreign material and should be logged accordingly. The sample should be washed no harder than necessary to remove the drilling mud.

Cuttings in oil base muds

In the case of oil base mud cuttings are quite representative of the formations as this type of mud prevents sloughing, but at the same time, however, they pose a problem of washing and handling. They cannot be cleaned by washing in water alone, so it is necessary to use a detergent in order to clean them out. For this purpose, many of liquid detergents -commercially available- can be utilized.

2.8.4 Contamination of Cuttings

Contamination of the cuttings is a direct result of the rig operations. Setting of casing, the mud additives, or any hole problems like pipe stuck, etc..., Can all lead to a cutting’s contamination. Contamination may or may not be easily detected. This depends on the logger’s experience.

2.9 TYPES OF RECORDED GASES

2.9.1 Cuttings Gas (formation gas)

It is the gas liberated from the drilled cuttings enters the wellbore mud. These are the gases continuously recorded and plotted against depth and used to represent the formation content. There are some factors that control the size of this formation gas shows.

2.9.2 Factors Affecting the Size of the Gas Show

- Rate of penetration; ROP
- Differential pressure; P
- Porosity; \emptyset
- Hole size; G
- Flow rate; Q
- Depth; ft or m

The ROP controls the concentration of gas in the mud for a given flow rate and is therefore the primary factor causing a variation of gas readings. The P and \emptyset control the degree of flushing. The hole size is G an important factor affects the size of the gas show, the larger the hole size, the more the cuttings, the more the gases liberated from these cuttings entering the mud. The Q affects the gas concentration but as the flow rate is usually constant for a bit run this is not as important factor as a change in ROP. As the Depth increases the gas shows should increase due to the increase of expansion that occurs.

2.9.3 Background Gas

Under normal drilling conditions, it is common for a relatively small amount of gas to be continuously in evidence. This “background gas” can originate from a previously drilled section, which contained a show and bleeds an amount of gas into the mud. Background gas is often methane with little or no wet gas. However, continuous high levels of background gas often suggest that the well is being drilled very close to balance (formation pressure is very close to mud head) and may indicate that a greater mud weight is required.

2.9.4 Trip Gas

It is quite common for an increase in the mud gas reading to occur at the first bottoms up circulation after a trip has been made. This occurrence referred to as “trip gas”.

In the process of “coming out of the hole”, the bit is being pulled through a mud filled cylinder of a diameter only slightly greater than the bit itself. As the bit is pulled through this cylinder formed by the hole wall, a swabbing action on the formation takes place and a momentary reduction in hydrostatic pressure occurs as bit is travelling upward. This enables the formation pressured gases to bleed into the hole each time the string is moved up. The resultant is an accumulated amount of gas at the bottom of the hole.

The amount of this gas depends on the following:

1. Differential Pressure (Mud Weight / Formation Pressure).
2. Pipe Movement Speed.
3. Mud Properties; viscosity.
4. Annular Size.

Under normal conditions trip gas will be indicative of increasing formation pressure especially when the amount of trip gas increases with depth and each successive trip.



Figure 17 Gas sensor

2.9.5 Connection Gas

Similar to the trip gas, a connection gas may appear at the first bottoms up circulation after a connection has been made. The reason of this is the reduction of the hydrostatic head when pumps are shut-off losing the effect of the E.C.D, along with the upward pipe movement that causes another negative swabbing pressure. This connection gas is used as a helpful guide towards drilling situation.

2.9.6 Circulation Gas

Is the gas being liberated into the borehole when actual “hole making” is stopped and the mud is circulated with the bit on bottom. The purpose of this practice is to get an idea of the degree of underbalanced at that particular depth internal.

2.9.7 Kelly Gas

Results from air trapped in the drill string during a connection. It can be easily identified by the time of its appearance relative to the time of connection and the pump rate to get this gas down the drill pipe up the annulus.

2.9.8 Carbide Gas

Is caused by the mud logger putting a specified amount of carbide in a dissolvable package into the drill pipe at the time a connection is made. This carbide reacts with the mud and creates an acetylene that is a check for the time required to pump cuttings off bottom to the surface; lag check.

2.10 GAS DETECTION ANALYSIS AND MONITORING EQUIPMENT

2.10.1 Gas Trap Assembly

Continuously operating explosion proof, electrically powered degasser for breaking-out entrapped gases from mud.

2.10.2 Total Gas Detector

Computer interfaced flame ionization detector which analysis a continuous stream of gas and air drawn from the gas trap, for total hydrocarbon gases.

2.10.3 Gas Chromatograph

Computer interfaced, programmable flame ionization baseline chromatograph with automatic sampling and calibration for detection of hydrocarbons gas components, C1, C2, C3, C4, iso & normal, and C5. Samples are either taken from the gas trap or by manual injection from the steam still.

2.10.4 Steam Still

It is an equipment used to measure the hydrocarbon gas dissolved in mud. A fresh mud sample is injected into a chamber and steam is used to elaborate the contained gas from mud. This is then sucked out using a special syringe and injected into the chromatograph for the analysis.



Figure 18 Gas monitoring equipment

2.11 SENSORS

The nature of the Logging system data acquisition systems allow complete flexibility in the choice of sensor inputs. The number of analogue sensors can readily vary with up to 64 inputs available. This means that additional sensors to those outlined below can be added upon request with minimal effort

Standard sensors list:

- Depth wheel
- Hook load
- Rotary speed
- Torque
- Electrical or mechanical
- Standpipe & choke Pressure
- Pit volume sensor
- Flow out paddle
- Pump stroke
- Mud temperature In/Out
- Mud density differential In/Out Mud conductivity



Figure 19 Junction box

Optional sensor list:

- Mud density - resonant
- Flow out - magnetic inductive
- Pit volume - ultrasonic
- Quantitative Fluro Technique; QFT
- Quantitative Gas Measurements; QGM
- Dissolved H₂S; Mud Duck
- Wireline depth
- Redact potential
- pH
- Dissolved oxygen
- Solids content
- Portable Density meter

2.11.1 Hook Load Sensor

The hook load sensor normally ties into the rig's deadline anchor system.



Figure 20 hook load sensor

2.11.2 Torque Sensors

Electric torque type

The sensor is clipped around the rotary table power cable at any convenient point and measures the rotary table current in amperes. As an option absolute torque can be monitored by combining the electrical torque sensor with a voltage measurement sensor fitted in the rotary motor power distribution cabinet.

Mechanical torque type:

A pressure transducer and connections similar to the hook load sensor are used for the mechanical torque sensor. The sensor is tied directly into the rig's hydraulic rotary torque system.



Figure 21 Torque sensor

2.11.3 Standpipe and Choke Pressure Sensor

Strain gauge type:

The Standpipe and Choke Pressure Sensors use a strain gauge transducer. The transducer consists of a box of four resistors. The only difference between the standpipe and choke sensors is the type of transducer fitted. All sensors should be tested to a specified pressure.



Figure 22 Stand pipe manifold

2.11.4 Analog Rotary Speed Sensor

The unit consists of a small low-power DC generator. This generator is driven via a belt and pulley from the rotary table drive shaft. The unit produces 7 VDC per 1000 Revolution Per Minute (RPM).

2.11.5 Pit Volume Sensors

The pit monitoring system uses a Delaval sensor to monitor individual pits. The computer system allows a total flexibility in defining the active and reserve pit systems. The configuration can be changed quickly through the keyboard. Alarms are computer controlled and can be set up for low and high levels on the active system, the reserve system, or on individual pits. The system can monitor up to 16 pits.

On trips the gain tank and trip tanks are also assigned through the trip monitoring programme for complete coverage of the pit system. On connections the expected flow back, gain encountered at various pump rates is entered. The system can correct for alarm if unexpected changes are seen during the connection. Delaval sensor use a non-contacting magnetic float activate discrete reed switches in reed switch resistance string inside a stainless-steel pole. The position of the float determines the resistance and hence the voltage fed to the computer.



Figure 23 Pit volume sensor

2.11.6 Flow Out Sensor

Flow Paddle Type

The flow out sensor normally specified is of the paddle type. Flow in the flowline causes a rotation of the paddle and a corresponding rotation of a 1 turn potentiometer. Various paddle sizes are available to suit the different flowlines.



Figure 24 Flow paddle type

Electromagnetic Wave Type (EWS System)

The sensor is installed in a closed V-shaped piping and measure the flow through generating induction voltage in a magnetic field. The V- shaped piping is designed to keep the inside of the sensor always filled with fluid.

2.11.7 Temperature Sensors

Two types of temperature sensor are in use. Either semiconductor thermistor transducers or platinum resistance elements (PRT) are used. These are moured in a protective cage at the end of all sensor poles. The Temperature-In sensor is mounted in the suction pit and the Temperature-Out sensor in the shaker header box.

2.11.8 Mud Density Sensor

Two silicon oil filled diaphragms are placed one foot apart in the drilling mud and a highly accurate differential pressure transducer interrogates the readings and transmits a 4-20 m.a. signal to the computer.

The sensors are mounted in the suction pit and in the shaker header box to provide the density In and out measurements.

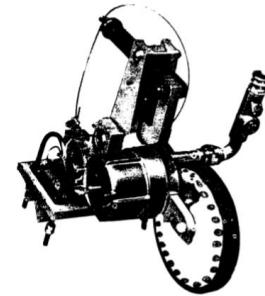

Figure 25 Mud Density sensor

For long term rig installations, it is recommended to install the resonant density sensors. Their superior accuracy and reliability give an on-line density reading that can be used with confidence by the customer and rig operator. These sensors can be mounted in the mud pump suction lines. This allows the sensors to pick up the density of the fluid being pumped. The sensors rapidly detect the presence of the wrong fluid being pumped and can save rig time and money by early detection of miss-aligned pits. Unlike differential pressure sensors they are unaffected by turbulence in the pits and they maintain accurate calibration over long periods.

2.11.9 Mud Conductivity Sensor

The sensor works on the principle of the toroidal coupling effect. The sensor contains two coils, known as the primary and secondary coils. AC current is fed to the primary coil by a Oscillator. The magnetic effect caused by this current is transmitted to the secondary coil by the medium surrounding the coils. This produces a current in the secondary coil, whose phase difference is related to the resistivity of the medium.



Figure 26 Mud conductivity sensor

2.11.10 Depth Sensor

Depth is monitored through a safe encoder wheel mounted on the crown sheaves on land rigs, jack-ups and platforms. On semi-submersible rigs either a wire line retriever is mounted on the rig floor to provide very accurate Kelly height or a combination of compensator opening sensor and crown wheel is used. The depth system provides continuous monitoring of depth, rate of penetration, running speeds, Kelly, block, compensator and riser position. The system is fully operative during tripping and other rig activities and also calculates bit off-bottom depth and running speed. This allows the calculation and display of swab and surge pressures while tripping.

The crown types

The depth wheel sensor assembly is mounted against the slow sheave of the crown wheel. It consists of a rotating wheel, twenty-four inches in circumference. Two proximity switches detect the wheel's movement. The proximity switches produce a quadrate signal which can identify the direction of movement of the wheel. The digital pulses from the switches are converted to up or down digital signals for compute The Draw work type This is smaller and simpler type of depth sensors which is mounted on the draw work.



Figure 27 PVT

2.11.11 Pump Stroke Sensor

Some can monitor up to six pumps continuously. The system can assign any combination of the pumps to the active and the auxiliary pump counters, which then monitor individual pump rates and total strokes. It calculates the total volume pumped, bottoms up, well circulation times and lags.



Figure 28 Pump stroke sensor

2.11.12 Digital Rotary Speed Sensor

Rotary table revolutions are normally measured with a digital encoder mounted in the rotary drive system. The sensor is driven by a flexible belt around the rotary motor shaft.

2.12 GAS TRAP ASSEMBLY

The mud trap assembly comprises an electric motor, impeller and trap chamber. 110-volt power is supplied to the motor from the unit and the wattage used is monitored to indicate the status of the trap in the mud. For example, a reduced wattage may indicate that the mud level has fallen below the trap housing requiring adjustment. The mud enters the trap through an opening in the base of the chamber where it is agitated into a vortex by the impeller. The vortex throws the mud upward on the inside wall of the chamber and liberates entrained gases. Air is drawn in through an opening in the trap body., mixes with any liberated gases and is carried via the hose at 6 cubic feet per hour to the unit. After passing a series of moisture and dust filters the air/gas mixture is distributed to gas detector, chromatograph and other ambient detectors (CO₂, H₂S etc.)

2.13 HYDROGEN SULPHIDE GAS DETECTOR

The gas detection system selects and monitor H₂S gas levels at various sensing points at the rig site. Sensors are usually installed at the bell nipple shale shaker, mud room and rig floor.



Figure 29 H₂S gas detector



3 DIRECTIONAL DRILLING

3.1 OBJECTIVES

After studying this section, the trainees should be able to perform the following:

- Describe the function of directional drilling operation in well servicing
- Describe the function of all components of the Rig Up equipment.
- Describe the preventive maintenance
- Describe the operational procedures
- Describe the rig up/rig down procedures related to directional drilling
- Describe directional drilling operator's general safety precautions and emergency response Procedures.

3.2 OUTCOMES

Upon completing their training, the participants should be able to:

- Demonstrate knowledge of all directional drilling services, applications and related products.
- Assist in directional drilling operation, tools, sensors, and procedures.
- Review MWD/LWD differences and compare it with Wire Line Services.

3.3 OVERVIEW

Directional drilling can generally be defined as the science of directing a wellbore along a predetermined trajectory to intersect a designated subsurface target.

3.4 APPLICATIONS

3.4.1 Multiple Wells from Offshore Structures

The most common application of directional drilling techniques is in offshore drilling. Many oil and gas deposits are situated well beyond the reach of land-based rigs. Drilling many vertical wells from individual platforms is both impractical and uneconomical. The obvious approach for a large oilfield is to install a fixed platform on the seabed, from which many directional boreholes can be drilled. The bottom hole locations of these wells are carefully spaced for optimum recovery (Figure 31).

In conventional development, wells cannot be drilled until the platform has been constructed and installed. This can mean a delay of several years before production begins. Such delay scan be considerably reduced by predrilling some of the wells through a subsea template while the platform is being constructed. These wells are directionally drilled from a semisubmersible rig and tied back to the platform once it has been installed.

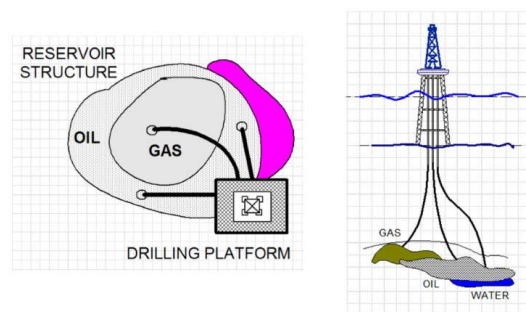

Figure 30 Multiple wells from offshore structures

3.4.2 Relief Wells

Directional techniques are used to drill relief wells in order to “kill” blowouts (Figure 32). Relief wells are deviated to pass as close as possible to the uncontrolled well. Heavy mud is pumped into the reservoir to overcome the pressure and bring the wild well under control.

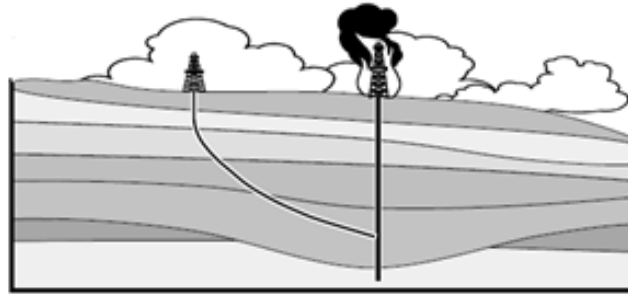

Figure 31 Relief Well

3.4.3 Controlling Vertical Wells

Directional techniques are used to “straighten crooked holes”. When deviation occurs in a well which is supposed to be vertical, various techniques can be used to bring the well back to vertical (Figure 33). This was one of the earliest applications of directional drilling.

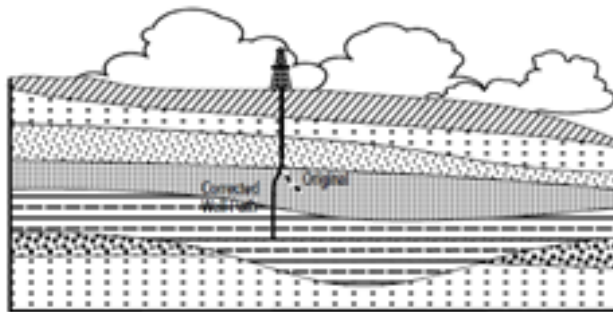

Figure 32 Controlling Vertical Wells

4.4 Sidetracking

Sidetracking out of an existing wellbore is another application of directional drilling. This is done to bypass an obstruction “fish” in the original wellbore, to explore the extent of a producing zone in a certain sector of a field, or to sidetrack a dry hole to a more promising target (Figure 34). Wells are also sidetracked to access more reservoir by drilling a horizontal hole section from the existing well bore.

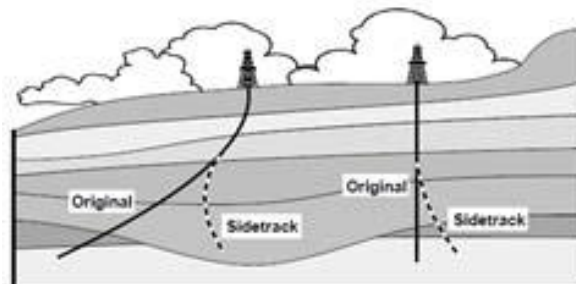

Figure 33 Side Tracking

4.5 Sidetracking into Multiple Sands from A Single Wellbore

A very profitable application of directional drilling pertains to the intersection of multiple sands from a single wellbore.

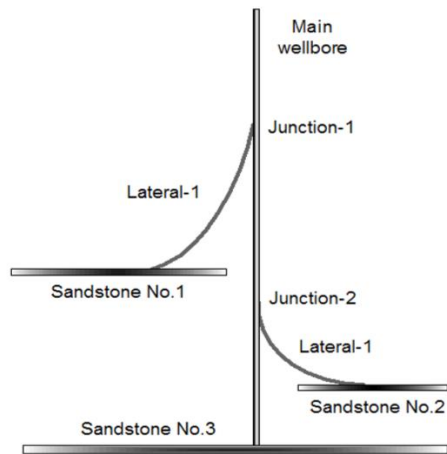

Figure 34 Accessing multiple sands with side track laterals from a main wellbore

4.6 Inaccessible locations

Directional wells are often drilled because the surface location directly above the reservoir is inaccessible, either because of natural or man-made obstacles

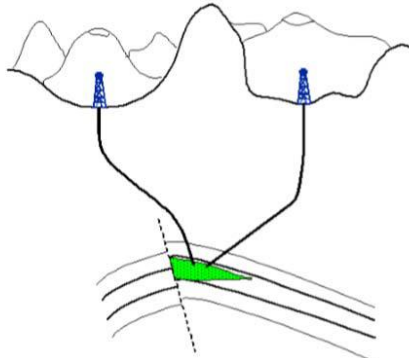

Figure 35 Drilling directional wells beneath natural surface obstructions

4.7 Fault Drilling

Directional wells are also drilled to avoid drilling a vertical well through a steeply inclined fault plane which could slip and shear the casing

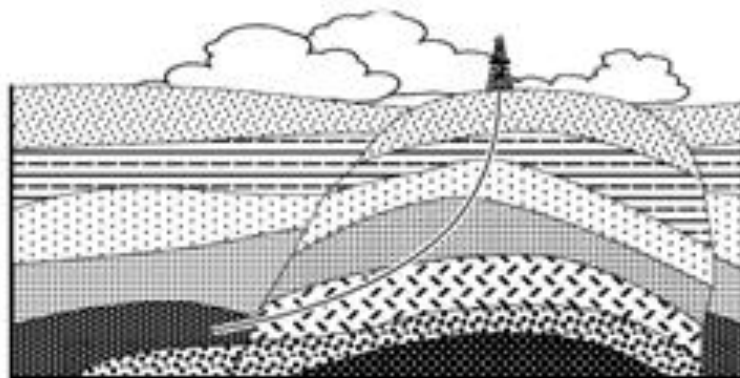

Figure 36 Fault Drilling

4.8 Salt Dome Drilling

Directional drilling programs are sometimes used to overcome the problems of drilling near salt domes. Instead of drilling through the salt, the well is drilled at one side of the dome and is then deviated around and underneath the overhanging cap.

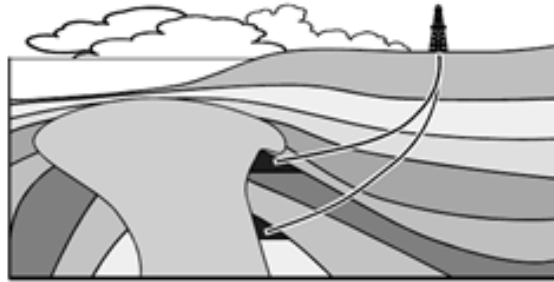

Figure 37 Salt Dome Drilling

4.9 Shoreline Drilling

In the case where a reservoir lies offshore but quite close to land, the most economical way to exploit the reservoir may be to drill directional wells from a land rig on the coast.

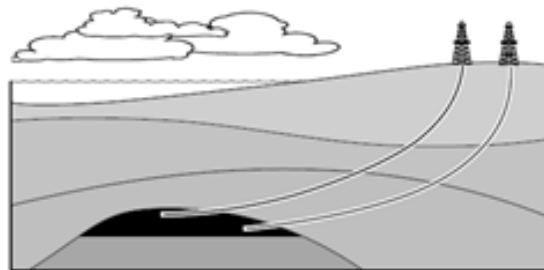

Figure 38 Shore Drilling

These are only some of the many applications of directional drilling. Although it is not a new concept, one type of directional drilling, horizontal drilling, is the fastest growing branch of drilling, with major advances occurring in tools and techniques. As with directional drilling, there are numerous specific applications for horizontal drilling.

3.5 PROCEDURES

3.5.1 Arrival at Rig Site

- a. Meet the safety representative.
- b. Meet the company representative
 1. Confirm job type and tools required.
 2. Present Lost in hole protection if applicable.
 3. Check with company man daily report requirements (Survey & Invoice & etc...)
 4. Gather all job information from company man.
 - a. Surface coordinate.
 - b. Elevation.
 - c. Expected flow rate.
 - d. Expected Mud weight.
 - e. Limit of Rate of Penetration.
 - f. Bit information (Type, Jets, Model, etc...)
 5. Review BHA requirements and design.
- c. Meet tool pusher.
 1. Confirm number of pumps.
 2. Pumps type.
 3. Pump stroke length.
 4. Pump liner size.
 5. Pump efficiency.
 6. Confirm with him location of the unit and surface equipment's.
 7. Determine electricity requirements.
- d. Meet the mud engineer
 1. Expected Mud type.
 2. Expected Mud weight.
 3. Expected LCM.

3.5.2 Equipment Receiving

- a. Verify received equipment with shipping paperwork to confirm all tools received.
- b. Place Radioactive equipment if applicable in safe area.
- c. Ensure that all of the required equipment for the job has arrived on location.
 1. LWD Unit.
 2. Surface equipment (Computer, racks, etc...)
 3. Non-mag drill collar (For survey calculation)
 4. Tools (Neutron, Density, Resistivity, etc...)
- d. Inspect all equipment from damage.
- e. Determine the primary and back tool string.
- f. Strap all tools of location primary and backup.
- g. Measure and clean interconnect between each tool.



Figure 39 MWD/LWD Cabin

3.6 RIG UP PROCEDURE

- a. Perform Job Safety Analysis (JSA).
- b. Wear the appropriate Personal Protective Equipment (PPE).
- c. Conduct Pre-Job Meeting and discuss (JSA).
- d. Rig up the unit
 1. Spot the unit as per Tool pusher instruction
 2. Ground and power the unit.
 3. Review the unit inventory and checklist.
 4. Setup all computers.
 5. Acquire an internet connection if available.
 6. Set up the real time transmission system to the client.
 7. Set up the printer.
- f. Install Rig Floor Display: Directional Driller can monitor Tool Face.
- e. Test, Rig up, and calibrate all sensors

1. **Draw works encoder and hook load sensors:** Current depth-tracking sensors digitally count the amount of rotational movement as the draw-works drum turns when the drilling line moves up or down. Each count represents a fixed amount of distance traveled, which can be related directly to depth movement (increasing or decreasing depth).



Figure 40 Hook Load Sensor and Drawwork Encoder

2. **Pump Stroke Sensor:** Flow-tracking sensors are used to monitor fluid-flow rate being applied downhole as well as the pump strokes required to achieve this flow rate. Data gathered from these sensors are essential inputs to calculating drilling-fluid hydraulics



Figure 41 Pump stroke sensor

3. **Pressure tracking sensor:** are used mainly to monitor surface pressure being applied downhole. Data gathered from these sensors are used either to validate calculated values or to confirm potential downhole problems such as washouts, kicks, or loss of circulation.



Figure 42 Pressure tracking sensor

3.7 EQUIPMENT AND TOOLS

3.7.1 Mud Motor

3.7.1.1 *Steerable Motor Assemblies or Positive Displacement Motor*

The most important advancements in trajectory control are the steerable motor assemblies, which contain PDMs with bent subs or bent housing. The first commercial PDM was introduced to the petroleum industry in the late 1960s. Since then, PDM use has been accelerated greatly for directional-drilling applications. Steerable motor assemblies are versatile and are used in all sections of directional wells, from kicking off and building angle to drilling tangent sections and providing accurate trajectory control. Among the PDM assemblies, the most commonly used deviation tool today is the bent housing mud motor.

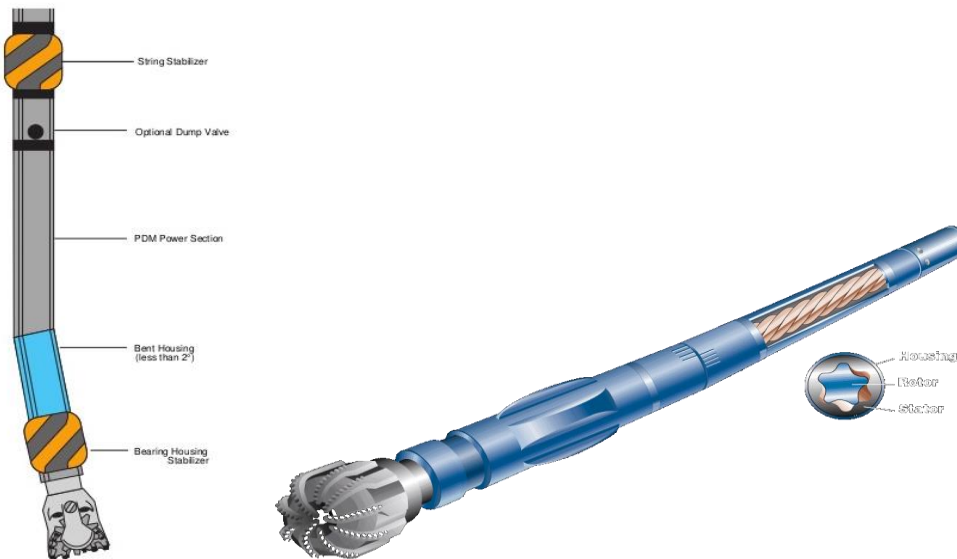

Figure 43 Mud Motor

3.7.1.2 Rotary Assemblies

3.7.1.2.1 Building Assemblies: Fulcrum Principle

Building assemblies use the fulcrum principle—a near-bit stabilizer, closely placed above the bit, creates a pivot point wherein the bending drill collars force the near-bit stabilizer to the low side of the hole and create a lateral force at the bit to the high side of the hole. Experience has shown that the more limber the portion of the assembly just above the fulcrum, the faster the increase in angle.

A typical build assembly uses two to three stabilizers. The first (near-bit) stabilizer usually connects directly to the bit. If a direct connection is not possible, the distance between the bit and the first stabilizer should be less than 6 ft to ensure it remains an angle-building assembly.

The second stabilizer is added to increase the control of side force and to alleviate other problems. Build rates can be increased by increasing the distance between the first and second stabilizers. When the distance between the stabilizers increases enough to cause the drill collar sag to touch the low side of the hole, the bit side force and bit tilt reach their maximum build rate for the assembly.

Generally, the drill collars will sag to touch the borehole wall when the distance between the stabilizers is greater than 60 ft. The amount of sag will also depend on the hole and collar sizes, inclination, stabilizer gauge, and weight on bit (WOB).

3.7.1.2.2 Holding Assemblies: Packed Hole.

The packed-hole assemblies contain three to five stabilizers properly spaced to maintain the angle. The increased stiffness on the BHA from the added stabilizers keeps the drill string from bending or bowing and forces the bit to drill straight ahead.

The assembly may be designed for slight build or drop tendency to counteract formation tendencies.

3.7.1.2.3 Dropping Assemblies: Pendulum Principle.

The pendulum effect is produced by removing the stabilizer just above the bit while retaining the upper ones. While the remaining stabilizers hold the bottom drill collar away from the low side of the wall, gravity acts on the bit and the bottom drill collar and tends to pull them to the low side of the hole, thus decreasing the hole angle. Pendulum assemblies sometimes can be run slick (without stabilizers). Although a slick assembly is simple and economical, it is difficult to control and maintain the drop tendency.

A dropping assembly usually contains two stabilizers. As the distance between the bit and the first stabilizer increases, gravity pulls the bit to the low side of the hole, increasing the downward bit tilt and bit side force. If the distance between the bit and the first stabilizer is too large, the bit will begin to tilt upward, and the drop rate will reach a maximum. With a higher WOB, the drop assembly could even start building angle. Generally, the distance between the bit and the first stabilizer will be approximately 30 ft. The second stabilizer is added to increase control of the side force.

Initially, low WOB should be used to avoid bending the pendulum toward the low side of the hole. Once a dropping trend has been established, moderate WOB can be used to achieve a higher penetration rate.

3.7.2 Rotary Steerable System (RSS)

A rotary steerable system (RSS) is a form of drilling technology used in directional drilling. It employs the use of specialized downhole equipment to replace conventional directional tools such as mud motors. They are generally programmed by the measurement while drilling (MWD) engineer or directional driller who transmits commands using surface equipment (typically using either pressure fluctuations in the mud column or variations in the drill string rotation) which the tool responds to, and gradually steers into the desired direction. In other words, a tool designed to drill directionally with continuous rotation from the surface, eliminating the need to "slide" a mud motor.

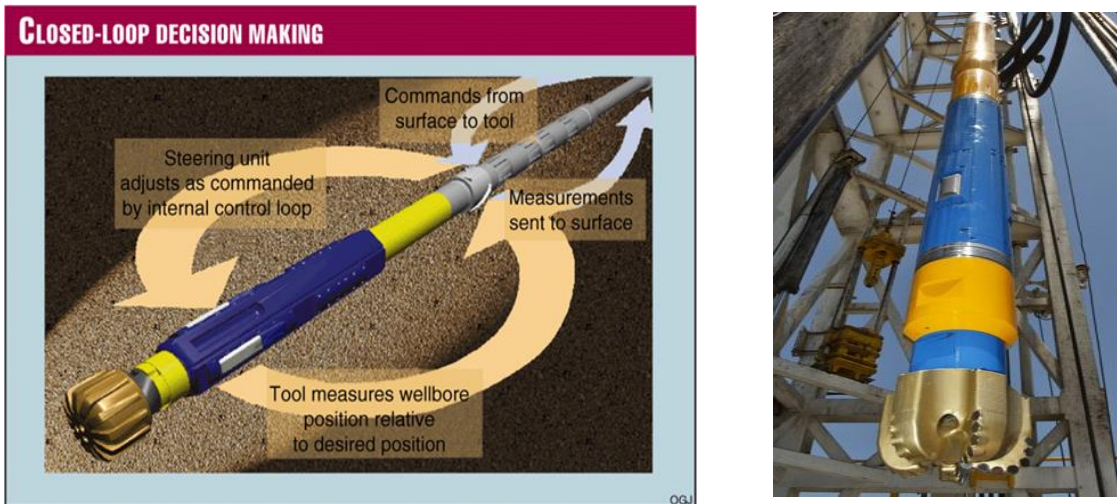

Figure 44 Rotary steerable system (RSS)

3.7.3 Measurements While Drilling MWD

3.7.3.1 Definition:

Measurements while drilling (MWD) is an oilfield service that provides a tool typically concerns measurement taken of the wellbore (the hole) inclination from vertical, and magnetic direction from north. Using basic trigonometry, a three-dimensional plot of the path of the well can be produced. Essentially, a MWD operator measures the trajectory of the hole as it is drilled (for example, data updates arrive and are processed every few seconds or faster). This information is then used to drill in a pre-planned direction into the formation which contains the oil, gas, water or condensate. Additional measurements can also be taken of natural gamma ray emissions from the rock; this helps broadly to determine what type of rock formation is being drilled, which in turn helps confirm the real-time location of the wellbore in relation to the presence of different types of known formations. MWD Tools also read Temperature, Pressure, Inclination, Azimuth, Resistivity, and other parameters.

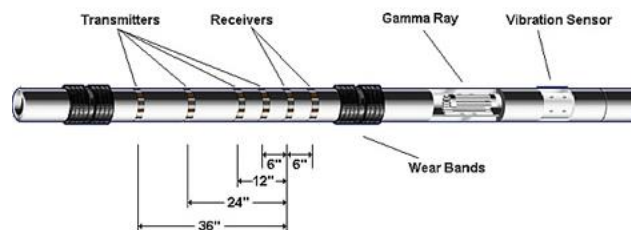

Figure 45 MWD Resistivity and Gamma Tool

3.7.4 Logging While Drilling LWD

3.7.4.1 *Definition:*

logging while drilling (LWD) is an oilfield service that provides a tool within the drill

string that transmits real-time formation information. The LWD tools are located near the end of the drill string.

The measurements recorded provide drilling engineers with critical well information so they may make time sensitive decisions about future well operations. LWD provides important well information on porosity, resistivity, acoustic waveform, hold direction and weight on bit. These measurements can be used to calculate ROP (rate of penetration) which is important in determining the speed at which the well is being drilled. Data is transmitted to the surface by pulses through the mud column.

3.7.4.2 *LWD vs Wireline:*

Advantages:

Logging while drilling:

1. Acquiring data after less time after drill passed which means less affected by mud invasion
2. Critical for geological decisions while drilling
3. More capable in tough environment (deviated wells, horizontal wells, unstable borehole)
4. Well placement

Wireline:

1. Smaller, Lighter and delicate
2. Accurate depth
3. high data speeds due to wire usage
4. good borehole contact
5. Communication and Powered using cable
6. Cased hole logging

Disadvantages:

Logging while drilling:

1. big, heavy and tough
2. Data variety depends on speed telemetry
3. limited control (Programmed before run in hole, unlink wireline where you can make 2 ways communications with the tools)
4. Powered using batteries and/or mud turbine
5. Vibrations & stick and slip

Wireline:

1. takes time
2. Measurements are taken after long time of finished drilling
3. specific coverage (as the tools don't rotate)
4. problem at high deviation (Tough logging condition is needed)
5. susceptible to hole condition

3.7.5 Real Time Data Log

MWD and LWD tool usually use **Real time Data Log** to transmit information to MWD/LWD cabin and Clint Forman screen to follow up the drilling progress and details. This information stored in memory of MWD tool for future review.

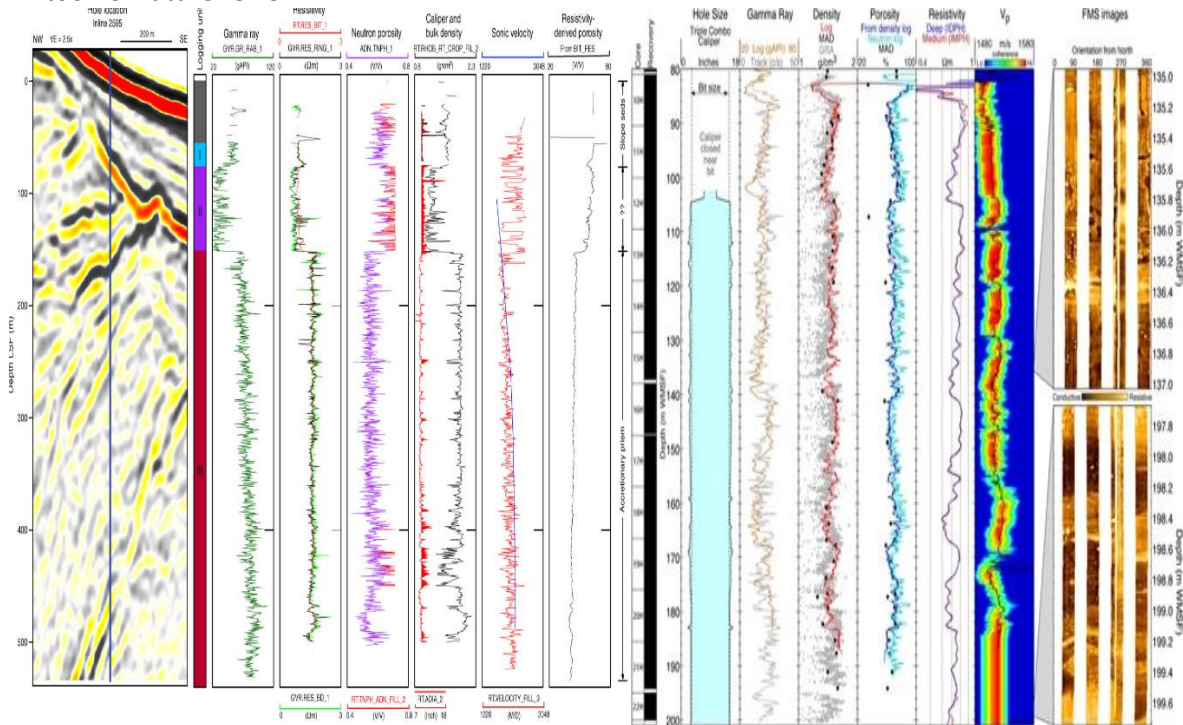

Figure 46 Real Time Log

3.8 DIRECTIONAL DRILLING LIMITATION

- a. Dogleg (Maximum well curvature)
- b. Reactive torque (counter- clockwise rotation of drill string)
- c. Drag (Friction between wellbore and BHA).
- d. Hydraulics (Circulation pressure).
- e. Hole cleaning practice.



4 CEMENTING

4.1 OBJECTIVES

After studying this section, the trainees should be able to perform the following:

- Describe the function of cementing in drilling and workover
- Describe the function of all components of the Rig Up Equipment
- Describe the operational procedures
- Describe the rig up/rig down procedures related to cementing

4.2 OUTCOMES

Upon completing their training, the participants should be able to:

- Perform basic mathematical calculations and basic reading comprehension and writing skills
- Demonstrate knowledge of all cementing services and related products
- Demonstrate proficient knowledge of the well cementing and related products

4.3 OVERVIEW

Oil well cementing is the process of mixing and displacing a cement slurry in the annulus between the casing and the formations exposed to the wellbore, where it is allowed to “set”, thus bonding the casing to the formation. Some additional functions of cementing include:

- Protecting producing formations
- Providing support for the casing
- Protecting the casing from corrosion
- Sealing off troublesome zones
- Protecting the borehole in the event of problems

4.4 HISTORY OF PORTLAND CEMENT

Joseph Aspdin, an English mason who patented the product in 1824, named it Portland cement because it produced a concrete that resembled the color of the natural limestone quarried on the Isle of Portland, a peninsula in the English Channel.

4.5 CEMENT MANUFACTURING

4.5.1 Raw Materials

Raw materials used cement manufacturing can be divided into two categories:

- A) Calcareous: those can be either limestone (Sedimentary or metamorphic), cement rock, shell, and coral.
- B) Argillaceous: those can be clays, shales, marls, mudstone or slate.

4.5.2 Raw Materials

Manufacturing process can be categorized into two types: Dry process and Wet process.

4.5.3 Manufacturing Process Procedures

- Raw Material Proportioned
- Grinding
- Heated in Kiln (1500°C)
- Converted to Clinker
- Gypsum (Calcium Sulfate) Added
- Pulverized

4.5.4 Manufacturing Process Schematics

Manufacturing process schematics for Wet process and Dry process, are demonstrated below in Figure 47 and Figure 48, respectively

4.5.4.1 Wet Process

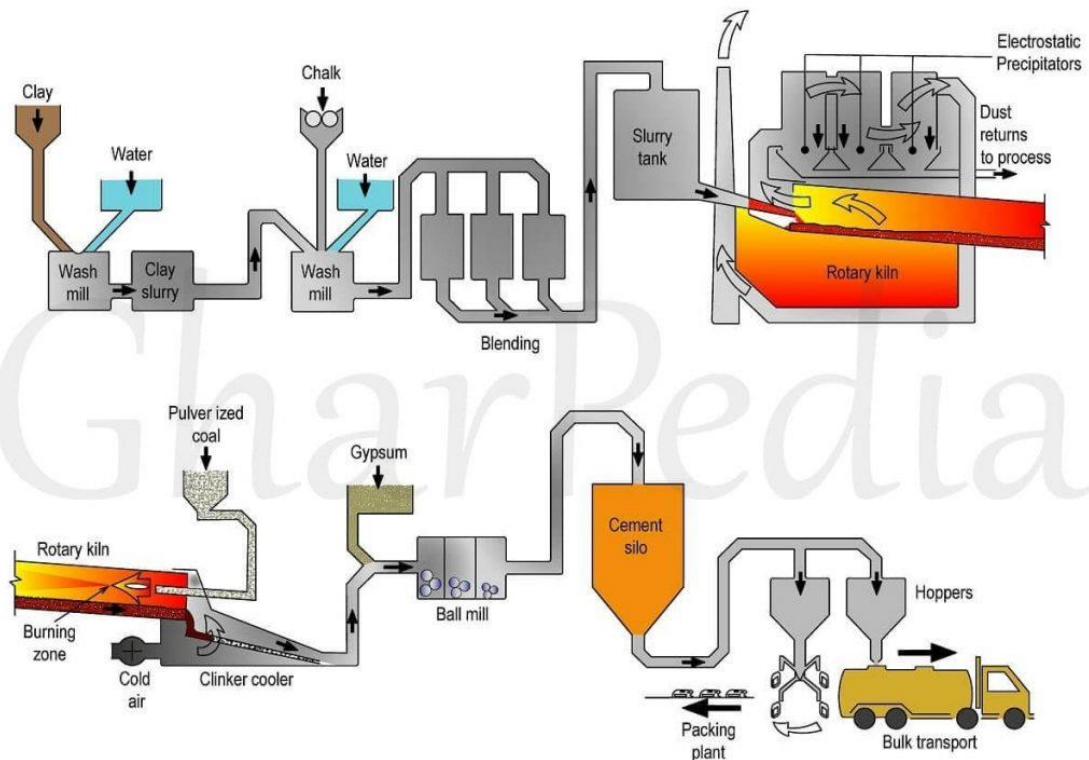

Figure 47 Wet Process for Manufacturing of Cement

4.5.4.2 Dry Process

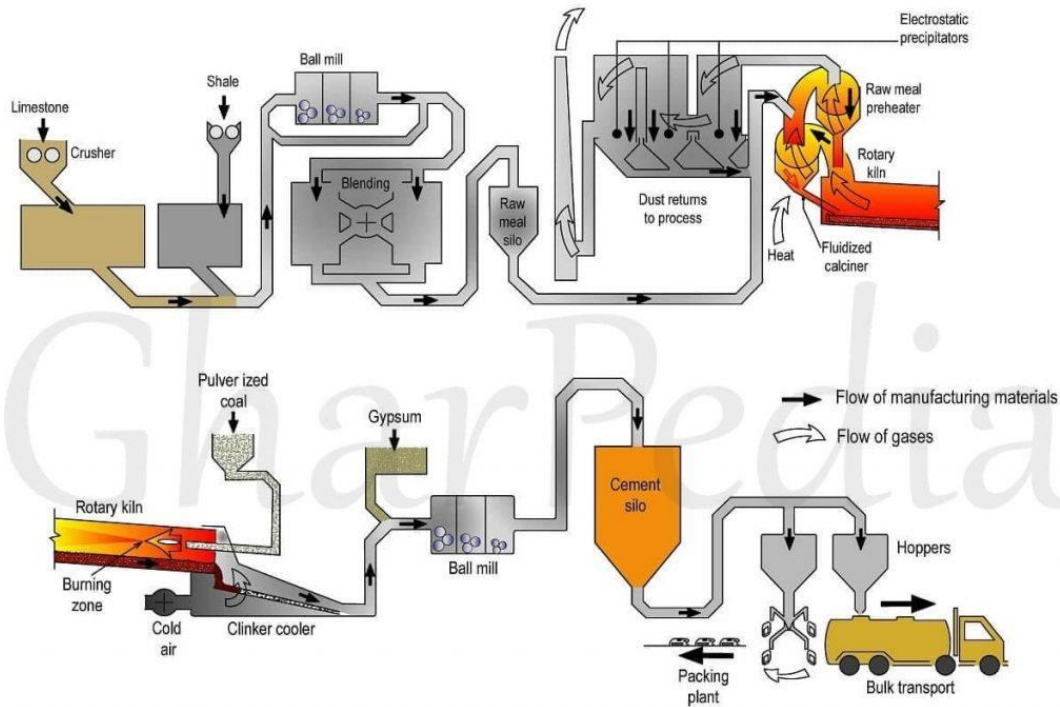

Figure 48 Dry Process for Manufacturing of Cement

4.6 CEMENT TYPES

Below is a general description of each API class, with its ASTM equivalent when appropriate.

Class A: Intended for use from surface to a depth of 6,000 ft (1,830 m), when special properties are not required. Available only in Ordinary type, Class A is similar to ASTM Type I cement.

Class B: Intended for use from surface to a depth of 6,000 ft (1,830 m), when conditions require moderate to high sulfate resistance. Class B is similar to ASTM Type II, and has a lower C3A content than Class A.

Class C: Intended for use from surface to a depth of 6,000 ft (1,830 m), when conditions require high early strength. Class C is available in all three degrees of sulfate resistance, and is roughly equivalent to ASTM Type III. To achieve high early strength, the C3S content and the surface area are relatively high.

Classes D, E and F are also known as “retarded cements,” intended for use in deeper wells. The retardation is accomplished by significantly reducing the number of faster-hydrating phases (C3S and C3A), and increasing the particle size of the cement grains. Since these classes were first manufactured, the technology of chemical retarders has significantly improved; consequently, they are rarely found today.

Class D: Intended for use at depths from 6,000 ft (1,830 m) to 10,000 ft (3,050 m), under conditions of moderately high temperatures and pressures. It is available in MSR and HSR types.

Class E: Intended for use from 10,000 ft (3,050 m) to 14,000 ft (4,270 m) depth, under conditions of high temperatures and pressures. It is available in MSR and HSR types.

Class F: Intended for use from 10,000 ft (3,050 m) to 16,000 ft (4,880 m) depth, under conditions of extremely high temperatures and pressures. It is available in MSR and HSR types.

Classes G and H were developed in response to the improved technology in slurry acceleration and retardation by chemical means. The manufacturer is prohibited from adding special chemicals, such as glycols or acetates, to the clinker. Such chemicals improve the efficiency of grinding, but have been shown to interfere with various cement additives. Classes G and H are by far the most commonly used well cements today.

Class G & Class H: Intended for use as a basic well cement from surface to 8,000 ft (2,440 m) depth as manufactured, or can be used with accelerators and retarders to cover a wide range of well depths and temperatures. No additions other than calcium sulfate or water, or both, shall be interground or blended with the clinker during manufacture of Class G and H well cements. They are available in MSR and HSR types.

The chemical compositions of Classes G and H are essentially identical. The principal difference is the surface area. Class H is significantly coarser than Class G, as evidenced by their different water requirements.

4.7 ADDITIVES

In well cementing, Portland cement systems are designed for temperatures ranges from below freezing in permafrost zones to 662°F (350°C) in thermal recovery and geothermal wells They also encounter pressures ranging from ambient to 30,000 psi (200 MPa) in deep wells. Accommodation of such variations in conditions was only possible through the development of cement additives. According to American Petroleum Institute Recommended Practice 10B, additives are materials added to cement slurry to modify or enhance desired property.

- Accelerators: Added to cement slurries to shorten the setting time and/or to accelerate the hardening process.
- Retarders: Any material which delays the setting time of cement slurry.
- Extenders: Allow addition of more water in a slurry, giving a higher yield(volume) and lower density.
- Weighting Agents: Increase the density of the cement slurry.
- Fluid Loss Additives: Controls fluid loss rate in cement slurries during placement and to the setting time.
- Lost circulation additives: Prevent cement slurry losses during cement placement.
- Dispersants: Adjust the particle surface charge on the cement grain to obtain the desired flow properties of the slurry.
- Antifoam agents: To control or eliminate entrapped air in the cement slurry, which can cause mixing problems

4.8 COMMONLY MEASURED CEMENT PROPERTIES

There are several properties of Portland cement, which are commonly measured. These properties are

- Thickening time
- Compressive strength
- Slurry volume
- Free water/fluid separation
- Rheological properties
- Fluid Loss rate
- Gas Migration

4.9 LABORATORY PROCEDURE AND METHODS OF REPORTING

- HPHT Consistometer: Thickening time testing
- Curing Chamber: Compressive strength testing
- Ultrasonic Cement Analyzer: Ultrasonic strength testing:
- Rotational Viscometer: Rheological testing
- Filter press: Fluid loss testing Measuring Cylinder: Free fluid cement specification test
- API Settling Tube: Slurry sedimentation test
- Static Gel Strength Analyzer: Static gel strength testing

4.10 PRIMARY CEMENTING

The main objective of primary cementing is placing cement slurry behind the casing. This can be performed in different methods: single stage, multi-stage and inner string cementing. In single stage, the cement is pumped into the casing, down to the shoe then up into the annulus. In some cases, when the casing string is long or the formation cannot support the hydrostatic pressure of a column of cement, a multi-stage can be applied. The procedure is cementing the bottom part of the annulus (up to the stage cementing tool depth), and then the second part is cemented by pumping the cement through a multi stage tool from the casing to the annulus up to the surface or pre-determined depth.

The height of the cement in the annulus depends on the objective of the job. For the conductor and surface casing, the annulus is covered all the way to the surface in order to provide more support to the casing. For the intermediate and production casing, the top of cement depends on the troublesome zones which have to be covered.

4.10.1 Stage Cementing (Single Stage)

It is the most common cementing operation in the drilling process. After running the casing with all its accessories: shoe, float collar and centralizers, and spacing out the casing string from the bottom, the cementing head is set at the top of the string. It has to be sure about the top and bottom plugs which are very important for a successful job. The casing is circulated at least for one string volume to clean it and to cool the bottom of the wellbore. The spacer is pumped and then the bottom plug (wiper plug) is dropped. The cement is pumped after dropping the bottom plug, and then the cement is followed by the top plug. When the bottom plug reaches its seat at the float collar, its diaphragm is ruptured (Pressure increase at the surface is an indication of plug landing) and the cement flows through the plug down to the casing

shoe, up into the annulus. When the top plug reaches the float collar, it lands on the bottom plug and stops the displacement of the cement by the drilling fluid. The pumping rates should be slowed when the plugs reach the float collar. The casing has to be pressure tested when the top plug lands on the float collar. The pressure has to be bled off slowly to check the valves functioning in the float collar and the casing shoe. If there is any back flow, the volume has to be pumped again, increase the pressure and keep it till the cement hardens. (See Figure 49 for single stage Cementing job).

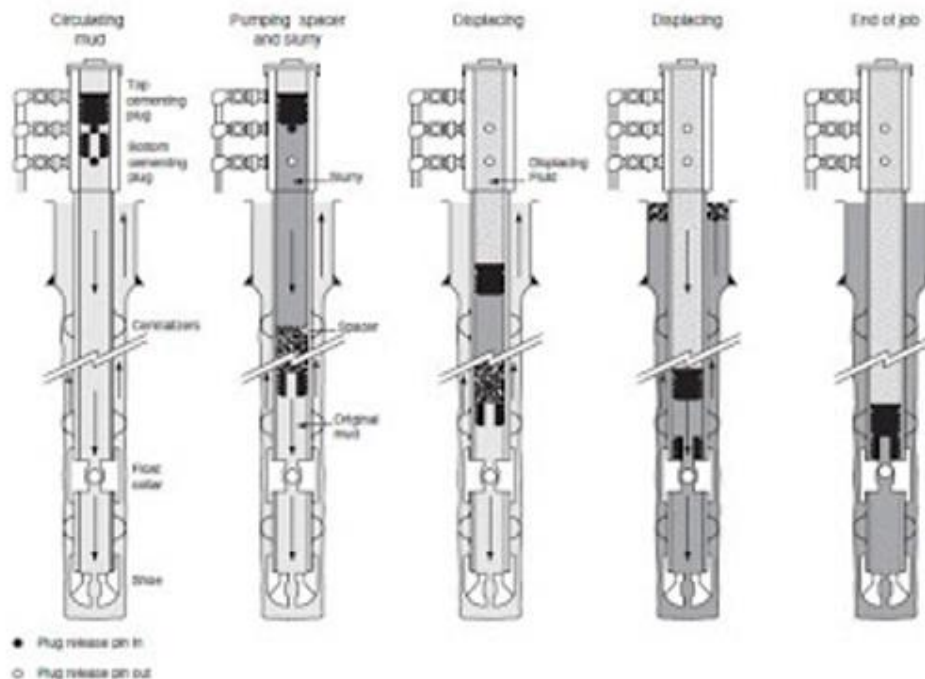

Figure 49 Single Stage Cementing Job

The displacement volume has to be well estimated before the job and controlled during the operations. When the volume is nearly to be totally pumped, the flow rate should be slowed to not generate any excessive pressure when the plugs land on the float collar. The mud return should be closely monitored to check if there is any fluid losses while cement displacement.



Figure 50 Cementing Head

4.10.2 Stage Cementing (Multi Stage)

This procedure of cementing is used when the pumping rate is long, high pump pressures or the hydrostatic pressure can exceed the fracture pressure of some troublesome formations. The operation is split into two stages See Figure 51:

- First stage: this part of the job is similar to single stage cementing except that a bottom plug is not used. A special plug is used to pass freely through the stage collar. the first stage is performed after the cement plug lands at the landing collar.
- Second stage: this final part of the job requires the use of a stage collar which allows pumping cement from inner part of the casing string into the annulus. The openings in the stage collar are sealed off by the inner sleeve. When the first stage is completed, a special dart/bomb is dropped from the surface and lands in the inner sleeve, and then the pressure is increased above the dart to open the ports. The annulus is cemented by pumping slurry through the ports, then a cement plug is dropped and displaced by drilling fluids till it lands at the stage collar, then the casing string is pressure tested.

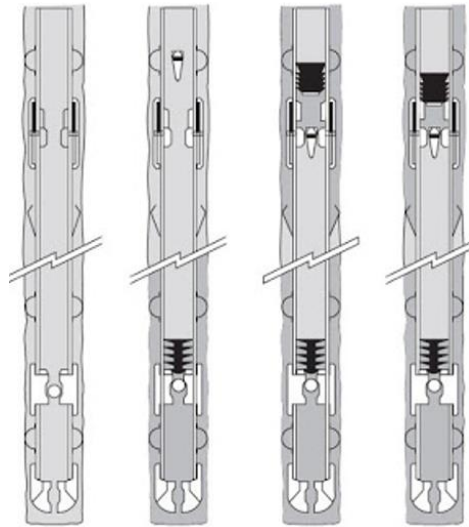

Figure 51 Multi-Stage Cementing Job

4.10.3 Inner String Cementing

Conventional cementing techniques are not suitable for large diameter casing due to many reasons:

- Large displacement volumes
- Long pumping time
- Plugs can get stuck in the casing due their large dimensions

Inner string cementing (Figure 52) is performed by using the stinger which is run by the drill pipe to the casing shoe and stabbed in it. Once the stinger is engaged, drilling fluids are circulated to ensure that there is no leak which can allow fluids to flow from the drill pipe into the casing. The cement slurry is then pumped through the drill pipe, down to the casing shoe up to surface through the annulus. The job is finished when getting cement on surface into the cellar and then the stinger is disconnected and pulled above the shoe. Circulation through the drill pipe is necessary in such situation to flush the drill pipe from any cement. In this type of cementing operations, no cement plugs are used.

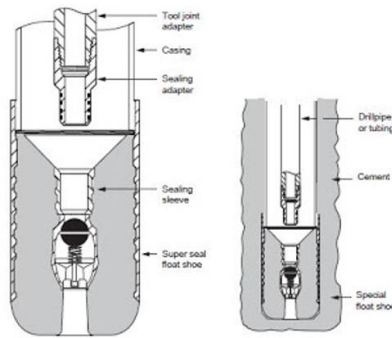

Figure 52 Inner String Cementing Job

4.11 SQUEEZE CEMENTING JOBS

This type of jobs is based on forcing the cement slurry through perforated casing into the annulus or the formation. Squeezing process is performed as a remedial operation and it is applied to:

- Maximizing oil production by sealing off gas and water production zones.
- Cementing parts of the annulus in case of primary cementing failure
- Sealing off lost circulation
- Preventing undesirable fluids migration into producing zones
- Repairing casing by forcing cement at leaking points

The squeezing jobs are performed in two ways: high pressure squeeze and low-pressure squeeze.

4.11.1 High Pressure Squeeze

In this process, the formation is fractured in order to allow slurry to flow into the fractured zones. The formation is initially fractured by pumping solids free fluids like water or brine to avoid making a filter cake. The fractures appear in the perpendicular plane to the less compressive stress. After fracturing the formation, the slurry is placed against the fractured zones and forced with slow rate to flow into fractures. When the cement is squeezed, any back flow is checked by releasing the pressure.

4.11.2 Low Pressure Squeeze

In this process the fracture gradient is not exceeded but the cement slurry is spotted against the formation, and when increasing the pressure, the fluid content of the slurry is forced to flow into the formation and the solid material of the cement builds a cake on the outer part of the formation. Applying this process helps to create an impermeable barrier across the perforated zone. Designing and controlling the fluid loss additives is very important in such operations. High fluid loss results in rapid dehydration of cement which leads to bridging and this can make it difficult to seal off the other perforated zones. Very low fluid loss leads to long process time due to slow filter cake building up.

Low pressure squeeze can be carried into two processes:

Running squeeze:

The cement in this process is pumped slowly and continuously till reaching the final planned pressure.

Hesitation squeeze:

In this method the slurry is allowed to dehydrate and form a required filter cake by stopping the pumping at planned and regular intervals of time.

4.12 CEMENT PLUGS

Cement plugs are placed into the casing or the open hole for many purposes:

- Abandoning depleted zones.
- Sealing off lost circulation zones.
- Sidetracking or directional drilling.
- Abandoning the entire well.

There are two techniques to place cement plugs: dump bailer and balanced plug.

Dump bailer:

This method requires the use of a bridge plug. The tool which contains the cement slurry is run with the wireline and it is opened when it touches the bridge plug and then the cement is dumped while pulling the tool. This method is used for shallow depths.

Balanced plugs:

It is the most common method. It is performed by running drill pipe string or tubing at the desired depth. The mud contamination is avoided by pumping spacer to provide proper placement. The volumes should be carefully calculated to obtain equal height of cement in the annulus and the drill pipe string when completing the displacement and then the string is slowly pulled with no rotation in order to do not disturb the balanced cement plug.

4.13 CEMENT PREPERATION

In preparing a well for cementing, it is important to establish the amount of cement required for the job. This is done by measuring the diameter of the borehole along its depth, using a caliper log. Utilizing both mechanical and sonic means, multifinger caliper logs measure the diameter of the well at numerous locations simultaneously in order to accommodate for variations in the wellbore diameter and determine the volume of the open hole.

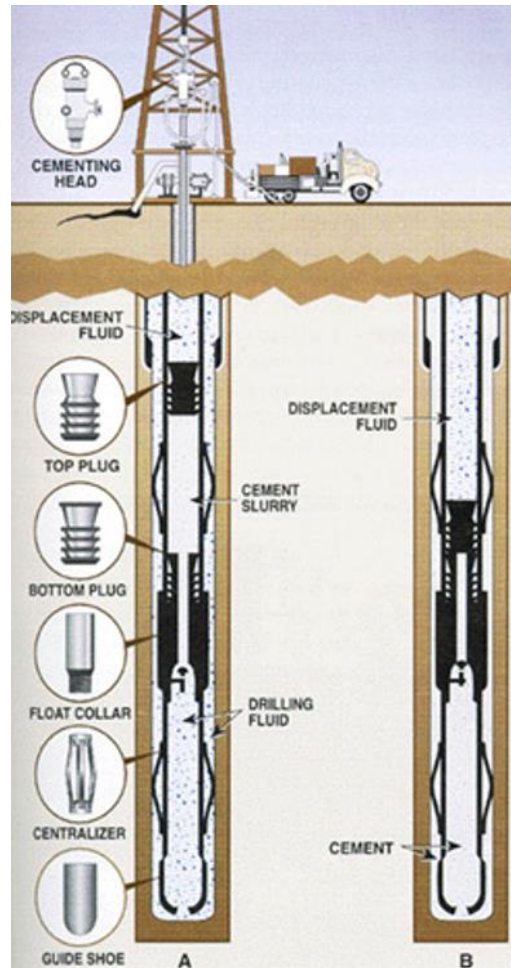

Figure 53 Cementing operation

Additionally, the required physical properties of the cement are essential before commencing cementing operations. The proper set cement is also determined, including the density and viscosity of the material, before actually pumping the cement into the hole.

4.14 CEMENTING A WELL

Special mixers, including hydraulic jet mixers, re-circulating mixers or batch mixers, are used to combine dry cement with water to create the wet cement, also known as cement slurry. The cement used in the well cementing process is Portland cement.

Cementing additives can include accelerators, which shorten the setting time required for the cement, as well as retarders, which do the opposite and make the cement setting time longer. In order to decrease or increase the density of the cement, lightweight and heavyweight additives are added. Additives can be added to transform the compressive strength of the cement, as well as flow properties and dehydration rates. Extenders can be used to expand the cement in an effort to reduce the cost of cementing, and antifoam additives can be added to prevent foaming during the cementing job. In order to plug lost circulation zones, bridging materials are added, as well.

4.15 ACCESSORIES

4.15.1 Float Shoe

Float shoe is a short and rounded shape component with non-return valve inside which is installed at the end of the casing. The advantages of a float shoe are as follows;

- Prevent mud flowing back while running casing and prevent cement from outside U-tubing back into casing due to unbalanced conditions while performing cementing operation.
- Help running casing to the well. The round shape of a float shoe prevents a casing string from hanging up and guiding a string into a wellbore. Some float shoes are made of high strength drillable material and can be used to reciprocate and rotate to pass any obstructions in a wellbore.



Figure 54 Float (guide) shoe

4.15.2 Float Collar

Also known a non-return valve is normally installed one or three joints above a float shoe. The advantages of a float collar are as listed below;

- Prevent mud and cement from U-tubing back into a casing string and float casing if required. This is the same advantage as a float shoe, and this also serves as a backup check valve in the casing string. If the check valve in a float shoe fails, a check valve in a float collar still performs the same purpose.
- Land cement wiper plug. Some models of float collars have non-rotating profiles. A cement plug landed into the profile will have fewer tendencies to be spun while drilling out. This will minimize time to drill out cementing plug because a cement wiper plug will not be spanned.
- Contain contaminated cement. The space between a float shoe and float collar called a “shoe track” will contain any contaminated cement when the top plug wipes any residual mud inside the casing. This will prevent bad cement at a casing shoe and help operators to achieve good formation integrity test (FIT) or leak off test (LOT) of the next well section.

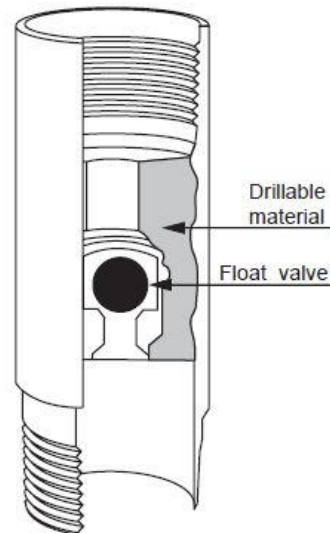

Figure 55 Float collar

4.15.3 DV Tool-Stage-cementing tools

- Or differential valve (DV) tools, are used to cement multiple sections behind the same casing string, or to cement a critical long section in multistage. Stage cementing may reduce mud contamination and lessens the possibility of high filtrate loss or formation breakdown caused by high hydrostatic pressures, which is often a cause for lost circulation.
- Stage tools are installed at a specific point in the casing string as casing is being run into the hole. The first (or bottom) cement stage is pumped through the tool to the end of the casing and up the annulus to the calculated-fill volume (height). When this stage is completed, a shutoff or bypass plug can be dropped or pumped in the casing to seal the stage tool. A free-falling plug/bomb or pump down dart is then used to hydraulically set the stage tool and open the side ports, allowing the second cement stage (top stage) to be displaced above the tool. A closing

plug is used to close the sliding sleeve over the side ports at the end of the second stage and serves as a check valve to keep the cement from U-tubing above and back through the tool.

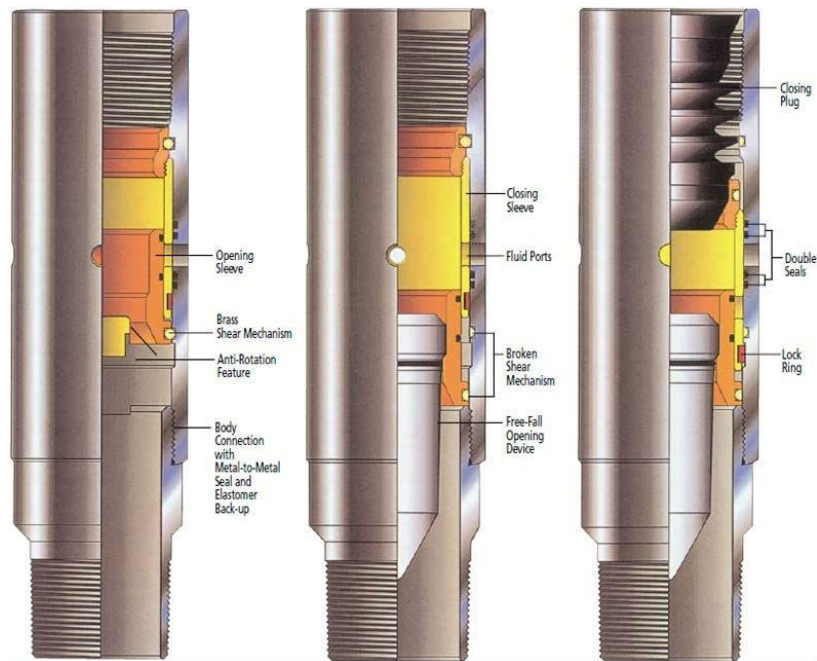

Figure 56 DV tool for stage cementing

4.15.4 Centralizer

Is a device to keep a casing string out of the well bore wall. The advantages of casing centralizers are listed below;

- Centralize casing string and minimize contact between casing string and wellbore
- Achieve proper cement around casing string and reduce cement channeling
- Minimize differential sticking and drag while running in hole



Figure 57 Centralizers

4.15.5 Stop Collar

Is provided for restricting centralizers from sliding lengthwise along the length of a casing.



Figure 58 Stop Collar

4.15.6 Wall Scratchers

These are most useful when running casing through a high fluid-loss drilling fluid. There are two types of wall scratchers, rotating scratchers used when the casing can be rotated (normally in vertical wells), and reciprocating scratchers used when the pipe is reciprocated (moved up and down). When these scratchers are placed in 15 to 20 foot intervals, overlapping cleaning occurs.

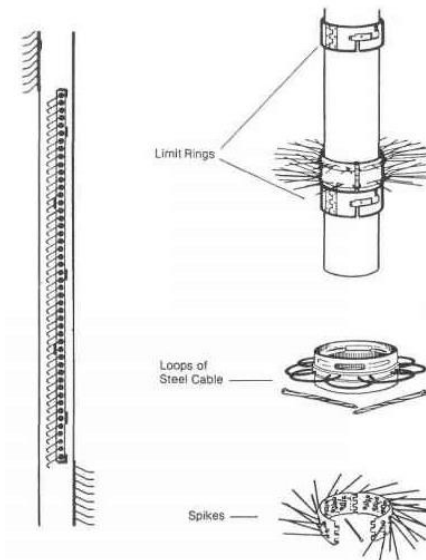

Figure 59 Scratcher

4.16 RUNNING TOOLS

4.16.1 Casing Scraper

Casing scraper is designed to mechanically assist in cleaning wellbore casings by scoring and removing mud film and other restrictive material from the inner casing wall diameters.



Figure 60 Casing scraper

4.16.2 Watermelon Mill

Watermelon mill was made to run in tandem with other mills designed and dressed in such a way that it can mill up or down. The watermelon mill is also designed to grind up casing into a fine metal powder instead of metal shavings.



Figure 61 String Mill

5 LINER HANGER

5.1 DEFINITION

Any string of casing with the top of the string below the surface of the ground.

5.2 TYPICAL LINER ASSEMBLY

Components of a Liner System

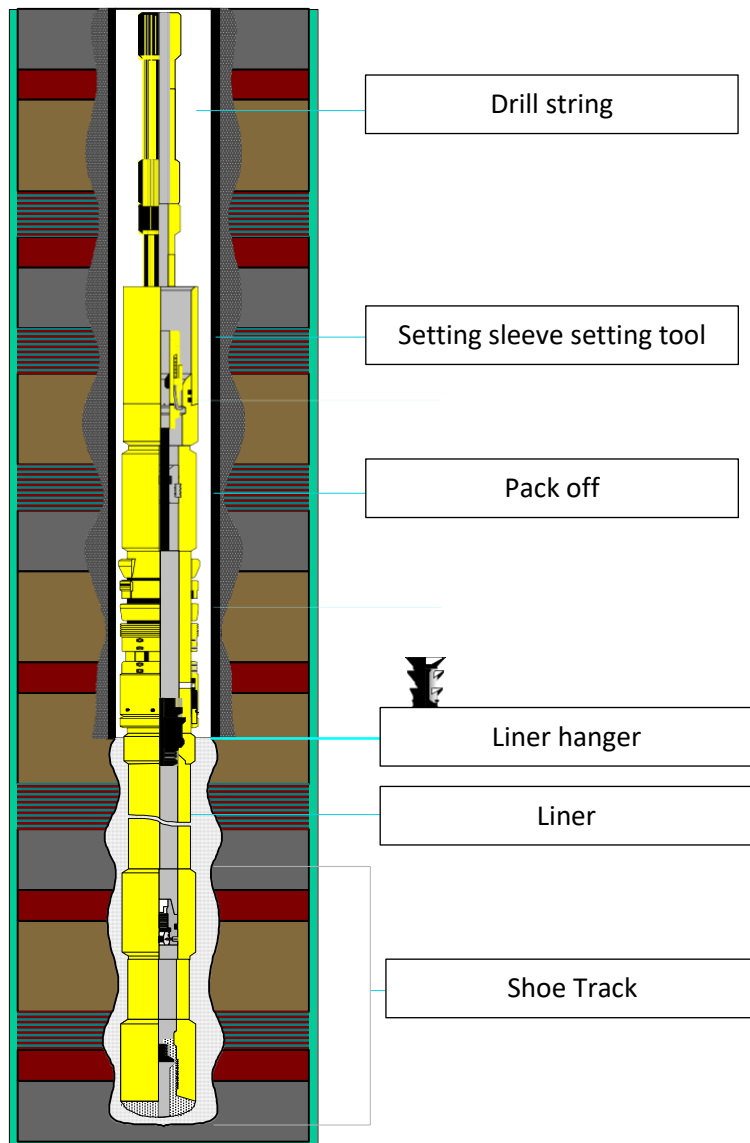

Figure 62 Liner hanger system components

5.3 REASONS FOR RUNNING LINERS

- Reduced casing cost.
- Case off open hole more rapidly and easily.
- Complete wells with less weight landed on the wellhead.
- Provide improved cement jobs.
- Provides good well control while drilling and completing.
- Good economics:
 - Cheaper to suspend casing from the bottom of an existing liner than to run casing to surface.
 - Prevents casing from buckling under its own weight if set on bottom.
- Less ID restriction:
 - Increased flow rate during drilling and cementing
- Drill with tapered string.
- Tensile load may exceed casing specifications.
- Well Construction Requirements.
 - Sidetracks.
 - Multi-Laterals.
 - Slotted Liner.

5.4 LINERS TYPES

5.4.1 Drilling Liner

- Set through a section of hole with further drilling planned.
- Extends intermediate casing.
- Isolates troublesome zones.
- Isolates weak or pressurized zones.

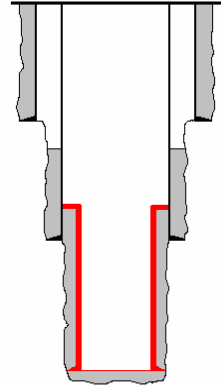

Figure 63 Drilling liner

5.4.2 Production Liner

- Set through or immediately above productive interval.
- Serves as completion casing.

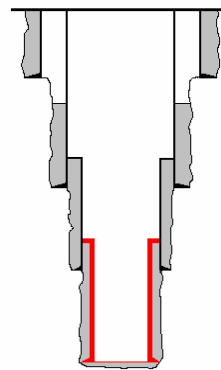

Figure 64 Production liner

5.4.3 Scab or Stub Liner

- Extends from top of previously set liner to a point up hole, but not reaching wellhead.
- Repair damaged or parted casing.

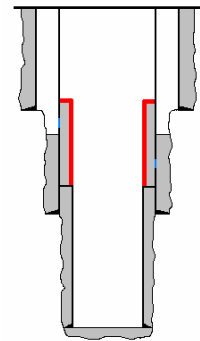

Figure 65 Scab/stub liner

5.4.4 Tie-Back Liner

- Extends from top of previously set liner to wellhead.
- Protects previous casings.
- Isolates previous liner top.

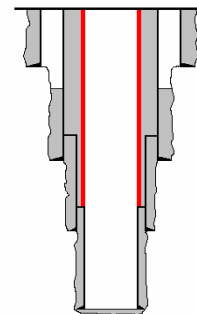

Figure 66 Tie-back liner

5.5 CONSIDERATION IN SELECTING TYPE OF LINER HANGER TO USE

- Mechanical or hydraulic set.
- Single or multiple cone.
- Liner rotation and/or reciprocation during cementing.
- Hole geometry.
- Liner hanger passing through the top of another line.

5.6 COMMON COMPONENTS IN LINER APPLICATIONS

A typical liner hanger system consists of the following components:

- A. Liner-top polished bore receptacle (PBR)
- B. Liner Top Packer OR Liner Setting Tool
- C. Cementing Pack-off
- D. Liner Hanger:
 - a. Mechanical set Hanger
 - b. Hydraulic Set Hanger
- E. Landing Collar
- F. Float Equipment:
 - a. Float Shoe.
 - b. Float Collar.
 - c. Reamer Shoe with Dual float valve
- G. Cement displacement system:
 - a. Wiper plug,
 - b. Drill pipe dart plug.

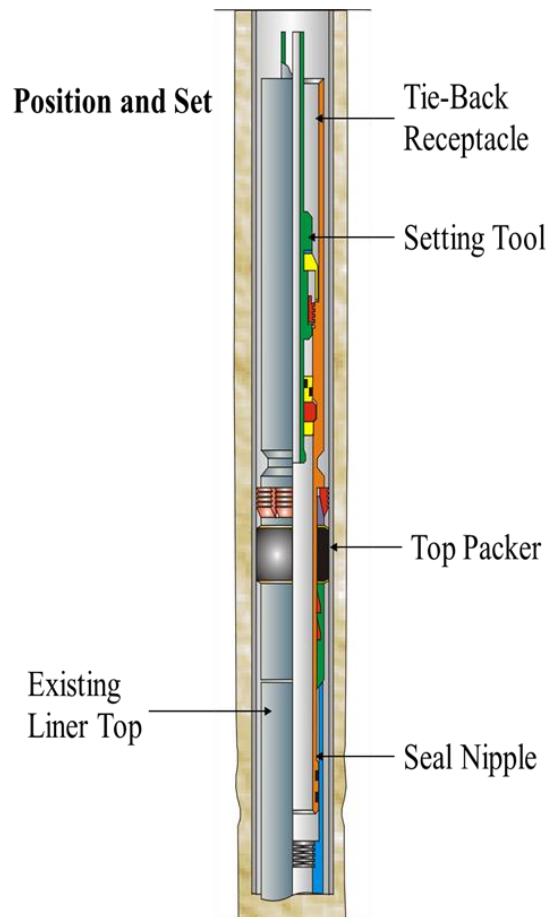

Figure 67 Common liner components and setting tool

5.6.1 Liner-Top Polished Bore Receptacle (PBR)

- Polished bore receptacle is a device that is honed with the internal diameter of the sealing surface. It is mainly used in tieback casing and for landing production seal assembly.
- It serves as the stem to isolate the hanger of installed cementing system, also it isolates the liner ID from the formation pressure that force out cement during the cementing process.

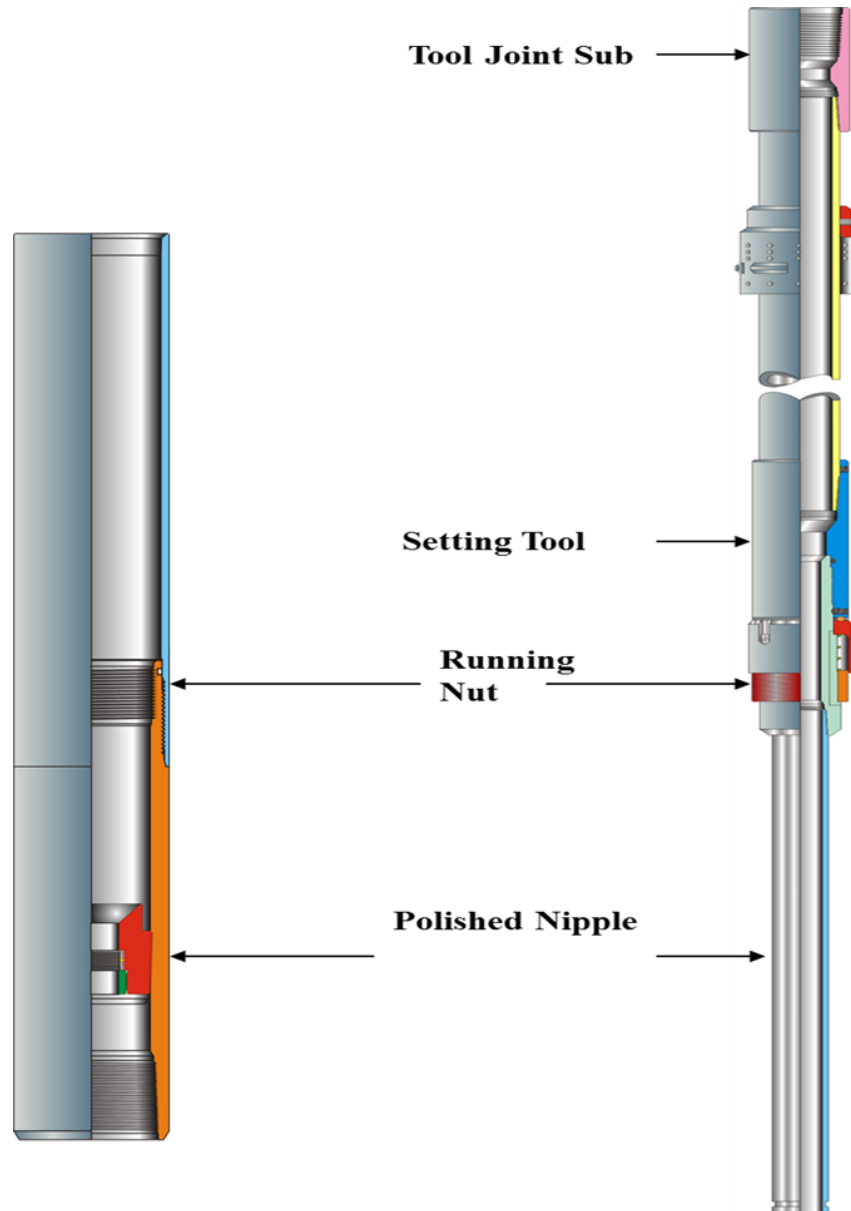

Figure 68 Liner-top polished bore receptacle (PBR)

5.6.2 Liner Top Packer OR Liner Setting Sleeve

- For many reasons liner-top packers are used to isolate the liner top after the hanger is set and cementing operations are completed:
- Isolation of formation pressure below the liner-top from the casing ID above.
- Isolation of treating pressures below the liner-top during fracture or acid work.
- Isolation of formation fluids while the cement sets, helping to stop gas migration.
- Isolation of lost-circulation zones.
- The only isolation above the production zone in un cemented liners.
- The liner-top packer can also be used as a tie-back completion or production packer.
- Has the profile for the attachment of the setting tool.
- The uppermost part of the liner.
- Comes with or without a tieback extension.
- Has a casing connection down for other tools.

5.6.3 Cementing Pack-off

- Run on bottom of the setting tool
- Serves as a pressure seal at the top of the liner
- Forces fluids to go around the bottom of the liner
- Allows actuation of hydraulically set tools
- Has casing connections on top and bottom

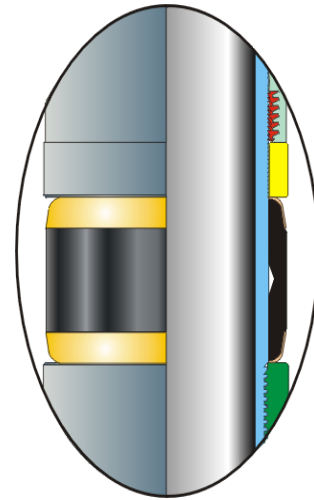

Figure 69 Liner Top Packer

5.6.4 Liner Hanger

- Supports the entire weight of the liner.
- Most liner hangers can be categorized by their setting mechanism, which is either hydraulic or mechanical.
- Hangers can be further defined by other features or abilities, such as the number of cones and the ability to rotate after the hanger has been set.
- Cones. In general, a greater number of cones means increased hanging capacity, but it also means longer and more expensive assemblies.
- Keeps the liner off the bottom of the well.
- Four basic types:
 - ◇ Mechanical set.
 - ◇ Mechanical rotating set.
 - ◇ Hydraulic set.
 - ◇ Hydraulic rotating set.
- Has casing connections top and bottom.

5.6.4.1 Mechanical Liner Hanger

- A mechanical liner hanger is set by string manipulation. The simplest mechanical liner hanger setting feature is a J mechanism. This design is easy to operate and reliably sets the hanger: It is picked up and rotated in the setting direction (usually right); then weight is slacked down on the hanger to set it.
- The main advantage of mechanical liner hangers over hydraulic models is the absence of a port in the body to transmit setting pressure.
- The main disadvantage of mechanical liner hangers is that deploying them to bottom and in deviated and/or extremely deep wells can be difficult.
- With mechanical liner hangers, manipulating the liner with the drill pipe through tight spots and setting it are difficult tasks. Rotation while running in hole can be problematic and can damage the setting mechanism (drag spring). In addition, setting mechanical liner hangers is difficult if not impossible should the liner become stuck.

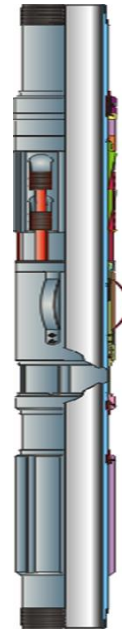

Figure 70 Mechanical liner hanger

5.6.4.2 Hydraulic Liner Hangers

- A hydraulic liner hanger is set by differential pressure across the hydraulic cylinder in the liner hanger.
- To prevent the hanger from pre-setting during deployment, the hydraulic cylinder is shear-pinned in place. Usually the maximum circulating pressure before the hanger is set is 50 percent of this setting pressure.
- A typical setting procedure for a hydraulic liner hanger requires dropping a ball, landing the ball on seat, pressuring up against it to activate the liner hanger, and then slacking down weight on the liner hanger.
- The main advantage of hydraulic liner hangers over mechanical models is that they can be set in high-angle and/or extremely deep wells because drill string or liner manipulation is not required to activate them. Unlike mechanical models, hydraulic liner hangers do not feature drag springs; therefore, they can be rotated and reciprocated to bottom with the correct running tools.

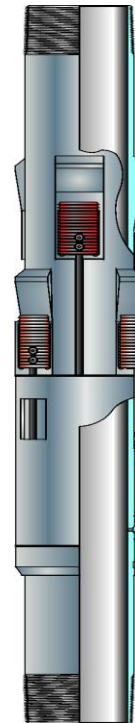

Figure 71 Hydraulic liner hanger

5.6.5 Landing Collar

- Located 1-2 joints above the bottom of the liner.
- When a setting ball is dropped and seated, pressure may be applied to activate hydraulic devices in the liner string, such as hydraulic-set liner hangers and external casing packers.
- Further increase in pressure shears out the ball and seat, restoring full circulation through the shoe for cementing operations.
- Two types of landing collars:
 - ◇ Type 1
 - * Catches liner wiper plug.
 - ◇ Type 2
 - * Catches liner wiper plug.
 - * Contains ball seat for actuating hydraulic tools.

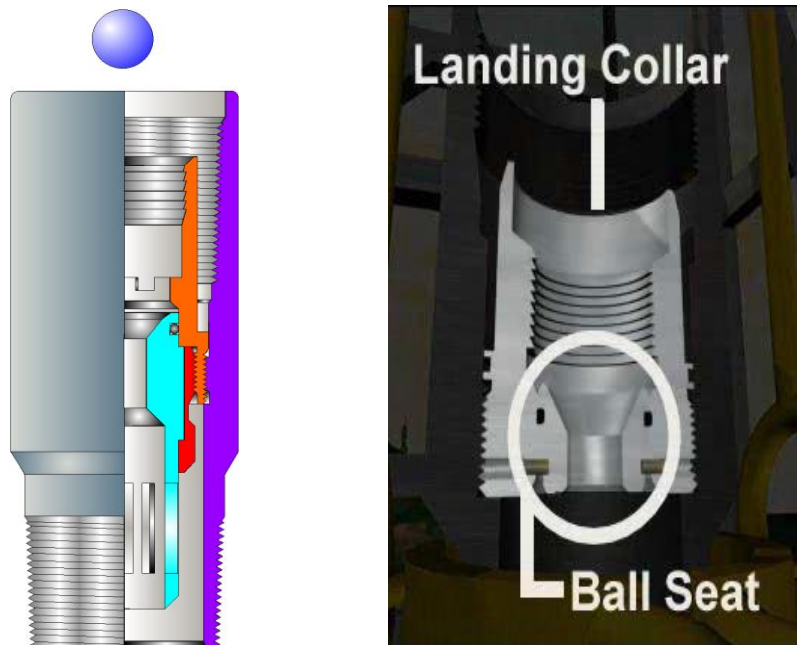

Figure 72 Landing collar

5.6.6 Float Equipment

5.6.6.1 *Float shoe*

It provides two main functions:

The shape of the shoe helps to guide the liner through open hole.

Single or double check valves prevent backflow inside the liner.

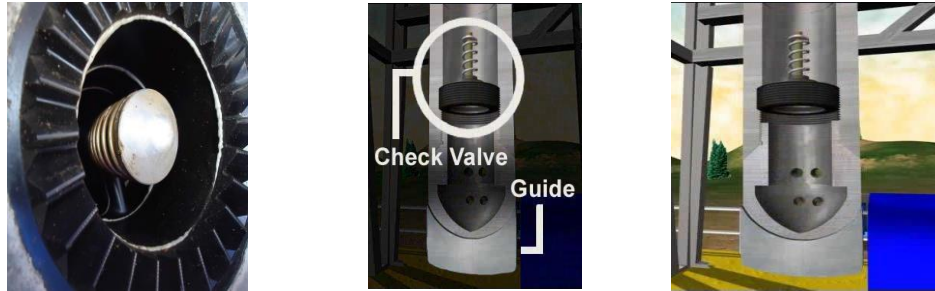

Figure 73 Float shoe

5.6.6.2 *Float collar*

- Insert tools or integral to liner.
- Provides back pressure valve in the liner.
- Prevents cement from "u-tubing" back into the liner after displacement around liner.
- Integral tools have casing connections top and bottom.

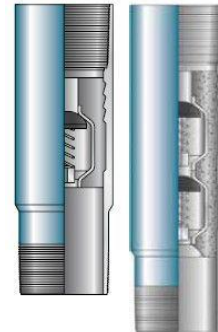

Figure 74 Float collar

5.6.6.3 *Reamer shoe with dual float valve*

- Rigid standoff stabilizer blades, combined with the cutting structure, clear a path for the casing or liner and most types of rigid centralizers installed above.
- Blade cutting structure facilitates both rotating and reciprocating applications to ensure safe passage of casing and liners.
- Large flow-directed ports cover the entire wellbore during rotating and reaming and prevent.
- Channeling during cement pumping.
- Dual float valve prevents cement backflow.
- Aluminum nose enables fast drill out with PDC or tri-cone bits.



Figure 75 Reamer shoe

5.7 CEMENT DISPLACEMENT SYSTEM

5.7.1 Liner Wiper Plug

- ◇ Separates cement from the displacing fluid
- ◇ After release, it wipes the cement from the inside of liner
- ◇ Latches into the landing collar

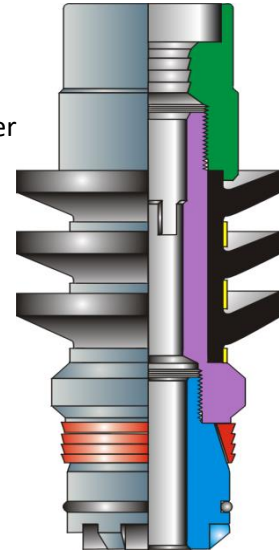

Figure 76 Liner wiper plug

5.7.2 Pump Down Plug (drill pipe dart)

- ◇ Dropped from surface.
- ◇ Acts nearly identically to a wiper plug except that it displaces the cement in the drill pipe and wipes the drill pipe ID.
- ◇ The drill pipe dart lands in the liner wiper plug and is used to launch it from the bottom of the running tools. The drill pipe dart features an anti-rotation ring, which locks it in position when it latches into the wiper plug.
- ◇ Separates cement from the displacing fluid.
- ◇ Allows the liner wiper plug to be released.

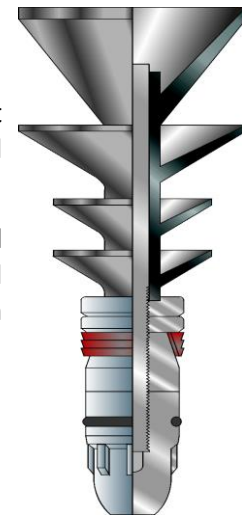

Figure 77 Drill pipe dart

5.8 OIL FIELD PRACTICAL PROCEDURE

5.8.1 Running a Hydraulic Liner Hanger with a Weight Set Packer

Note: Procedure is generalized and may vary depending upon well conditions/customer requirements.

So, Prior to running the Liner, a meeting with all personnel involved with the Liner running and cementing operations should be held to discuss and plan operations in detail. The discussion should also include known hole conditions, such as dog legs, tight spots, hole angle and other drilling problems encountered while drilling the hole, in addition to the type and volume of cement and displacement.

Features:

1. Float shoe.
2. Float collar.
3. Landing collar.
Receptacle.
4. Weight set packer with setting adapter. and Tieback
5. Hydraulic hanger.
6. Liner wiper plug.
7. Drill pipe pump down plug.
8. Setting tool.
9. Cementing manifold with plug valve and ball drop valve.

Operation:

Step 1: Make up cementing manifold onto one joint of drill pipe and lay down same. This is for easy access once liner is at desired depth.

Step 2: Pick up the first liner joint with the float shoe and check same.

Step 3: Make up float collar onto next liner joint (or to customer requirements)

Step 4: Check operation of float equipment.

Step 5: Make up landing collar at least one joint above float collar.

Step 6: Continue RIH with the determined casing joints as per running program. At last casing joint, complete fill the casing.

Step 7: The assembled liner hanger should now be picked up. Check all liner hanger parts and Be sure the hanger slips do not get damaged when picking up. Install liner wiper plug on the bottom of the slick joint.

Step 8: Make Up and torque the liner hanger with casing and torque all the liner hanger connections.

Step 9: Fill the liner TBR with mud.

Step 10: Slack down till the liner setting tool on the slips.

Step 11: Fill from the liner setting tool to remove the trapped air under the liner back off bushing.

Step 12: Pick up the cement manifold with its joint and Mack Up same with the liner setting tool.

Step 13: Check the liner Back off bushing and Cement Manifold by Circulation with maximum 500 psi with the total casing capacity while that performing safety meeting to explain the following: -

- Rabbit any D/P joint go in hole.
- No rotation to the right or to the left-hand side for any reason all the time.
- If circulation required, the max. pressure will be 500 psi or max 4 BBM for.
- The running speed will be approximately 2-3 minutes per stand from slips out till slips in.
- Fill every 10 stands to avoid the effecting back pressure against the shoe.

Step 14: Recording the string P/UP wt. = Klbs & S/D wt = Klbs.

Step 15: Lay Down the cement manifold with its joint.

Step 16: Make up running string on top of setting tool. Run liner in hole, approximately 2-3 minutes per stand.

Step 17: When liner is at previous casing depth, note string weight up and down.

Step 18: When shoe is at +/- 20 ft from the desired depth, Pick up the cement manifold with the landing joint and Mack Up same with string, wash down till tag the bottom and confirm same.

Step 19: start circulating bottoms up through the cementing manifold, with no more than 6 BBM To avoid wash out the shoe.

Step 20: Monitor pressure throughout circulation.

Recording the string P/UP wt = Klbs & S/D wt = Klbs.

Step 21: Set liner hanger and release the setting tool as following: -

- Set rotary slips while the bottom of shoe +/- 3 ft off bottom.
- Drop setting ball and circulate down at a rate of 2 bbls./min. When the ball seats slowly pressure up, apply 1700 psi to set the liner hanger.
- Slack of, observe weight indicator for loss of weight as the hanger slips set. Slack off liner weight plus 20 Klbs of drill pipe weight.
- Pressure up to +- 3000 PSI to shear out the ball seat from the landing collar.
- With weight of liner + 10,000 lbs. of drill pipe weight on the hanger slips, the rotational locking dogs on the running tool move out of the locking slots in the setting adapter and the thrust bearing moves down against the bearing shoulder in the setting adapter, allowing load to be taken by the bearing. With the locking dogs and thrust bearing in this position, the running nut is now in the neutral position.
- Set the rotary slips.
- Rotate drill string 25 – 30 right hand turns with free torque, this will disengage the nut and release the running tool. Pick up max. 3 feet to see that the setting tool is release Set back down the 10,000 lbs. on the running tool. Break circulation and record circulating pressure while mixing cement slurry.

Step 22: Performing cement job by pumping pre-flush and spacer.

Step 23: Commence displacing with cementing unit/rig pumps, as the drill pipe pump down plug reaches the liner wiper plug, slow displacement to approximately two (2) bbls. per min. or less. When pump down plug latches into liner wiper plug, the pressure will increase approx. 1,000 PSI (field adjustable).

Step 24: When the liner wiper plug shears (indicated by a drop in pressure) continue to displace until the plug seats in landing collar. Bump plug with approx. 500-1000 PSI over the final displacement pressure, or as required by customer.

Step 25: Hold pressure for one (1) to three (3) minutes and bleed off, check if floats are holding.

Step 26: Set the packer as following: -

- Mark the D/P's Before pick-up.
- Pick up drill string 6 ft to exit the tamping setting dogs out of the liner TBR.
- Slack down and observe the weight will slack off in another position.
- Continue slack down, observe the packer shearing @ (20 – 40 klbs), continue slack down till apply total of 60 – 70 klbs against the packer.
- P/U till get the D/P wt.
- Repeat slack down and applying 60 – 70 klbs against the liner packer.

Step 27: Pick up drill string. At the lower end of the slick joint is a reduced O.D. which allows the dogs of the retrievable cement bushing to retract from the R.C.B. profile in the setting adapter. Picking up, moves the reduced O.D. to a position directly under the R.C.B. allowing the dogs to collapse onto the smaller O.D. of the slick joint, thus enabling the R.C.B. to be pulled out the setting adapter, and retrieved along with the running tool.

Step 28: Continue P/U drill string till the end of the slick joint just above the liner TBR.

Step 29: AS per customer Requirement, Pressure test the packer.

Step 30: Long way or Reverse circulate as per the customer requirement.

Step 31: Pull out of hole with running tool.

6 UNDER BALANCE DRILLING

6.1 WHAT IS UNDERBALANCED DRILLING?

In underbalanced drilling (UBD), the hydrostatic head of the drilling fluid is intentionally designed to be lower than the pressure of the formations that are being drilled.

The effective down hole circulating pressure of the drilling fluid is equal to the hydrostatic pressure of the fluid column, plus associated friction pressures, plus any pressure applied on surface.

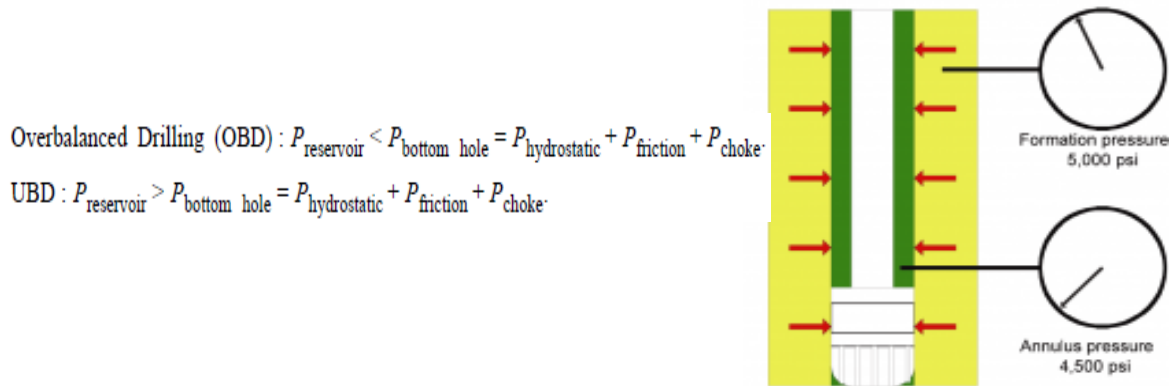

Figure 78 Hydrostatic and formation pressure relationship

Flow from any porous and permeable zones is likely to result when drilling underbalanced. This inflow of formation fluids must be controlled, and any hydrocarbon fluids must be handled safely at surface.

One of the main differences from conventional drilling. In conventional drilling, pressure control is the main well control principle, while in UBD, flow control is the main well-control principle.

In UBD, the fluids from the well are returned to a closed system at surface to control the well. With the well flowing, the blowout preventer (BOP) system is kept closed while drilling, whereas in conventional overbalanced operations, drilling fluids are returned to an open system with the BOPs open to atmosphere.

6.2 WHY DRILL UNDERBALANCED?

The reasons for UBD can be broken down into two main categories:

A. Maximizing hydrocarbon recovery.

There is no invasion of solids or mud filtrate into the reservoir formation. This often eliminates the requirement for any well cleanup after drilling is completed.

1. **Early Production**, the well is producing as soon as the reservoir is penetrated with a bit.
2. **Reduced Stimulation**, because there is no filtrate or solids invasion in an underbalanced drilled reservoir.
3. **Enhanced Recovery**, Because of the increased productivity of an underbalanced drilled well combined with the ability to drill infill wells in depleted fields, the recovery of bypassed hydrocarbons is possible.
4. **Increased Reservoir Knowledge**, during an underbalanced drilling operation, reservoir productivity and the produced fluids can be measured and analyzed while drilling. This allows a well to be drilled longer or shorter, depending on production requirements.

B. Maximizing hydrocarbon recovery.

1. **Differential Sticking**, the absence of an overburden on the formation combined with the lack of any filter cake serves to prevent the drill string from becoming differentially stuck.
2. **No Losses**, a reduction of the hydrostatic pressure in the annulus reduces the fluid losses into a reservoir formation.
3. **Improved Penetration Rate**, the lowering of the wellbore pressure relative to the formation pressure has a significant effect on penetration rate. The reduction in the "chip hold down effect" also has a positive impact on bit life.

6.3 DRILLING FLUID SYSTEMS

Correct selection of the fluid system used in UBD is the key to a successful UBD operation. Initial fluid selection for UBD operations is classified into five fluid types based primarily on equivalent circulating density: gas, mist, foam, gasified liquid, and liquid.

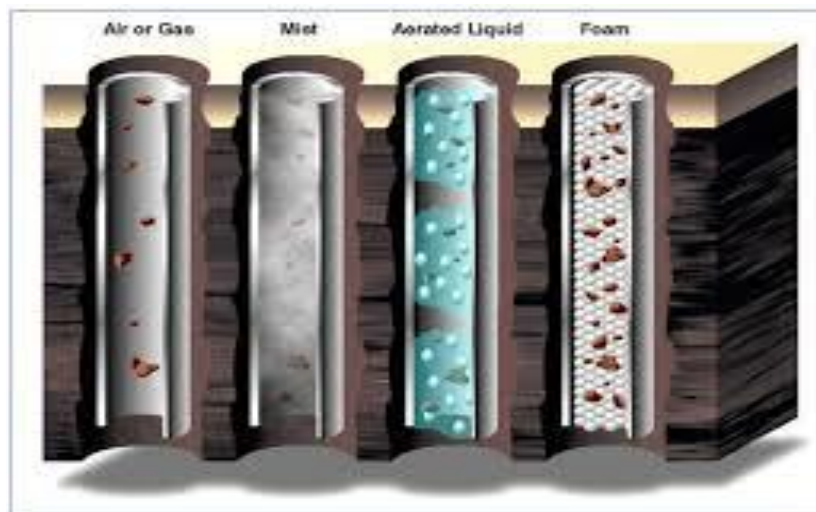

Figure 79 Different underbalance drilling fluid system

6.3.1 Gaseous Fluid

Gaseous fluids are basically the gas systems. In initial UBD operations, air was used for drilling. Today, air drilling or dusting is still applied in hard rock drilling and in the drilling of water wells. The use of air in hydrocarbon-bearing formations is not recommended because the combination of oxygen and natural gas may cause an explosive mixture.

6.3.2 Mist System

Drilling with stable foam has some appeal because foam has some attractive qualities and properties at the very low hydrostatic densities that can be generated with foam systems.

6.3.3 Gasified Systems Gas

is injected into the liquid to reduce the density. The use of gas and liquid as a circulation system in a well significantly complicates the hydraulics program. The ratio of gas and liquid must be calculated to ensure that a stable circulation system is used. If too much gas is used, slugging will occur. If not, enough gas is used, the required bottom hole pressure will be exceeded, and the well will become overbalanced.

6.3.3.1 Drill pipe Injection

The most common method of aeration is to inject gas or multi-phase fluids through the drill string. Injection through the drill string, has the benefit of requiring smaller upper hole and casing sizes and allows the benefit of gas expansion to aid in cuttings transport in horizontal wells. Furthermore, this method requires a lower gas volume for a given underbalanced condition than if the gas is injected part-way up the annulus.

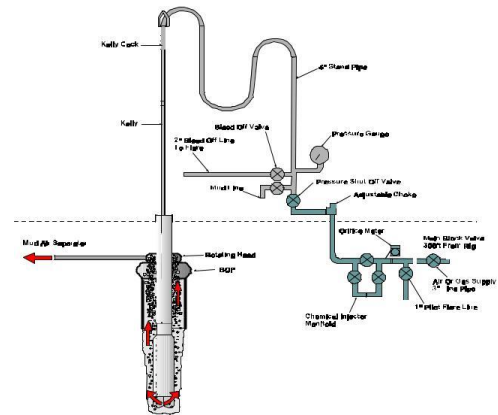

Figure 80 Gas lift system

6.3.3.2 Annular Injection

Annular injection through a concentric string is most commonly utilized offshore in the North Sea. In new wells, a liner is set inside the target formation. The liner is tied back to surface using a modified tubing hanger to suspend the tieback string.

6.3.3.3 Parasite-String Gas Injection

The use of a small parasite string strapped to the outside of the casing for gas injection is used only in vertical wells.

The For-safety reasons, two 1- or 2-in. coiled-tubing strings are strapped to the casing string above the reservoir as the casing is run in. Gas is pumped down the parasite string and injected onto the drilling annulus.

6.4 DOWN HOLE EQUIPMENT FOR UBD OPERATIONS

6.4.1 Pressure While Drilling Sensor "PWD"

Adding a down hole gauge or sensor on the injection side and in the drill string enhances the UBD operation and helps the team optimize the drilling process and increase the knowledge of the reservoir.

The PWD data have several valuable applications, including:

1. Accurate downhole measurement of equivalent circulating density (ECD).
2. Kick detection, including shallow water flows.
3. Swab/surge pressure monitoring while tripping and reaming.
4. Monitoring of hole cleaning.
5. Accurate downhole measurement of hydrostatic pressure and effective mud weight.
6. Accurate leak-off test (LOT) and formation integrity test (FIT) data without circulating to condition the mud.



Figure 81 Pressure while drilling sensor "PWD"

6.4.2 Conventional MWD Tools in UBD

The most common technique for transmitting MWD data uses the drilling fluid pumped down through the drill string as a transmission medium for acoustic waves. Mud-pulse telemetry transmits data to the surface by modifying the flow of mud in the drill pipe in such a way that there are changes in fluid pressure at surface.

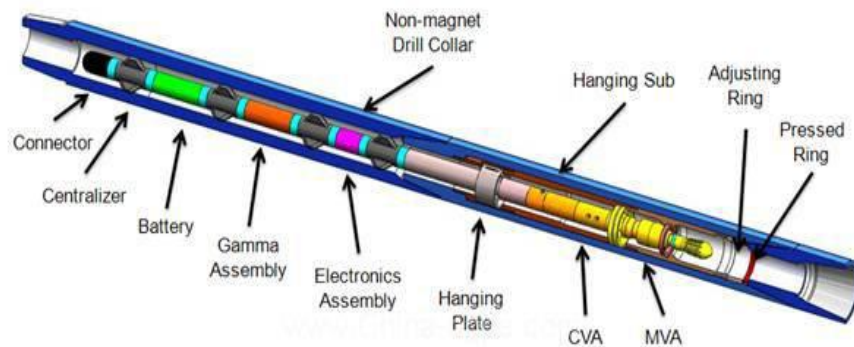

Figure 82 Measuring while drilling "MWD"

6.4.3 Electromagnetic Measurement While Drilling (EMWD)

Electromagnetic telemetry transmits data to the surface by pulsing low-frequency waves through the Earth. The first application of PWD measurements has been primarily for drilling and mud performance, kick detection, and ECD monitoring.



Figure 83 Electromagnetic measurement while drilling “EMWD”

6.4.4 Non-return Valves

Float valves are necessary for UBD to prevent influx of reservoir fluids inside the drill string either when tripping or making connections.

6.4.5 Deployment Valves

The deployment valve is run as an integral part of the casing program, allowing full-bore passage for the drill bit when in the open position. When it becomes necessary to trip the drill string, the string is tripped out until the bit is above the valve, at which time the deployment valve is closed and the annulus above the valve bled off. At this time, the drill string can be tripped out of the well without the use of a snubbing unit and at conventional tripping speeds.



Figure 84 Deployment valve

6.5 UBD OPERATIONS SURFACE EQUIPMENT

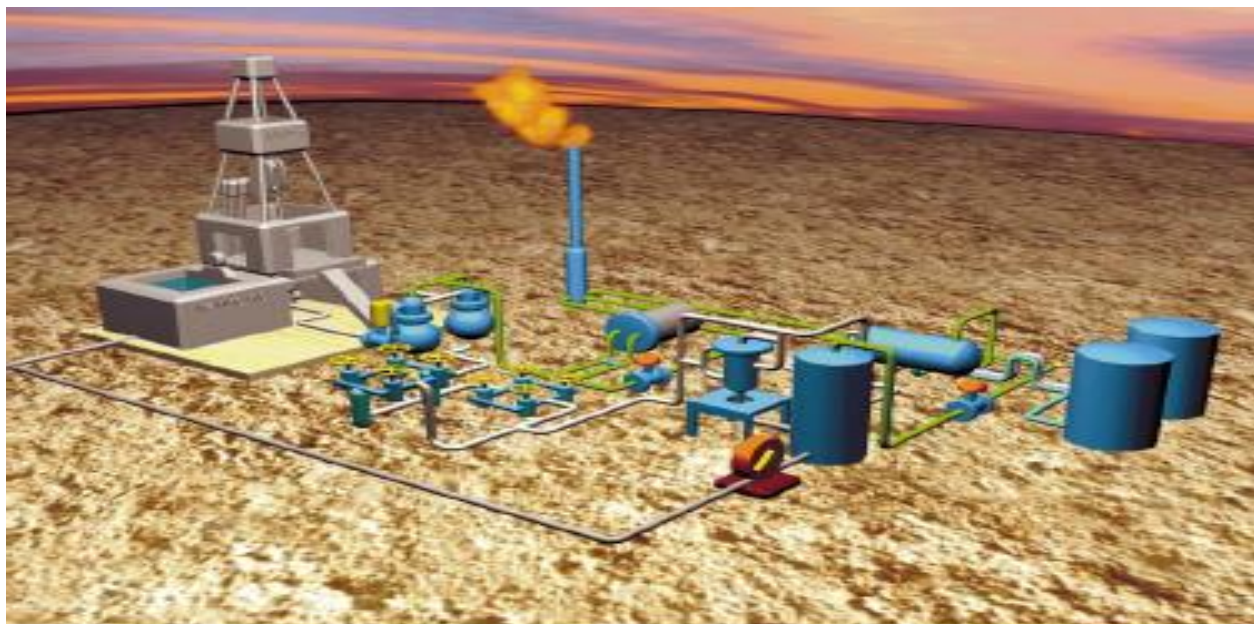

Figure 85 UBD Surface equipment

The surface equipment for UBD can be broken down into four categories:

- Drilling system.
- Gas-generation equipment.
- Well-control equipment.
- Surface separation equipment.

6.5.1 Drilling Systems

Hole size and reservoir penetration, as well as directional trajectory, determine whether coiled tubing or jointed pipe is the optimal drill string medium. If the hole size required is larger than 6 $\frac{1}{8}$ in., jointed pipe may need to be used. For hole sizes of 6 $\frac{1}{8}$ in. or smaller, coiled tubing can be considered.

6.5.2 Gas-generation Equipment

6.5.2.1 *Natural Gas*

If natural gas is used for UBD, a natural gas compressor may be required; this would need to be reviewed once the source of the gas is known. Most production platforms have a source of high-pressure gas, and in this situation, a flow regulator and pressure regulator are required to control the amount of gas injected during the drilling process.

6.5.2.2 *Cryonic Generation*

The use of tanked nitrogen could be considered on onshore locations, where a large truck could be used for its supply. Cryogenic nitrogen in 2,000-gal transport tanks provides high-quality nitrogen and utilizes equipment that is generally less expensive.

6.5.2.3 Nitrogen Generation

A nitrogen generator is no more than a filtering system that filters nitrogen out of the atmosphere.

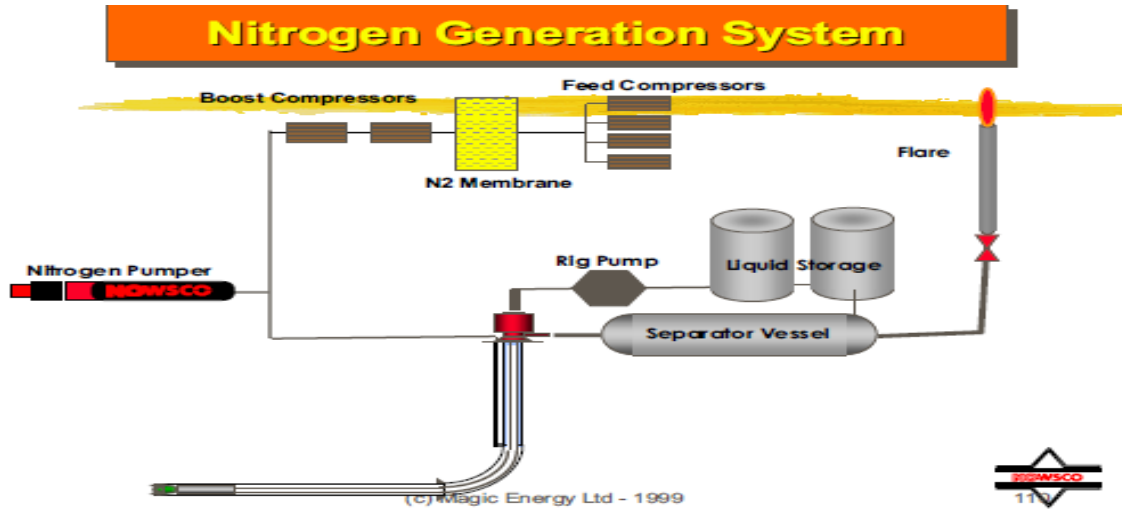

Figure 86 Nitrogen generation

6.5.3 Well-Control Equipment

6.5.3.1 Jointed-Pipe Systems

The conventional BOP stack used for drilling is not compromised during UBD operations, A rotating control-head system and primary flowline with ESD valves is installed on top of the conventional BOP.

If required, a single blind ram, operated by a special Koomey unit, is installed under the BOP stack to allow the drilling BHA to be run under pressure.

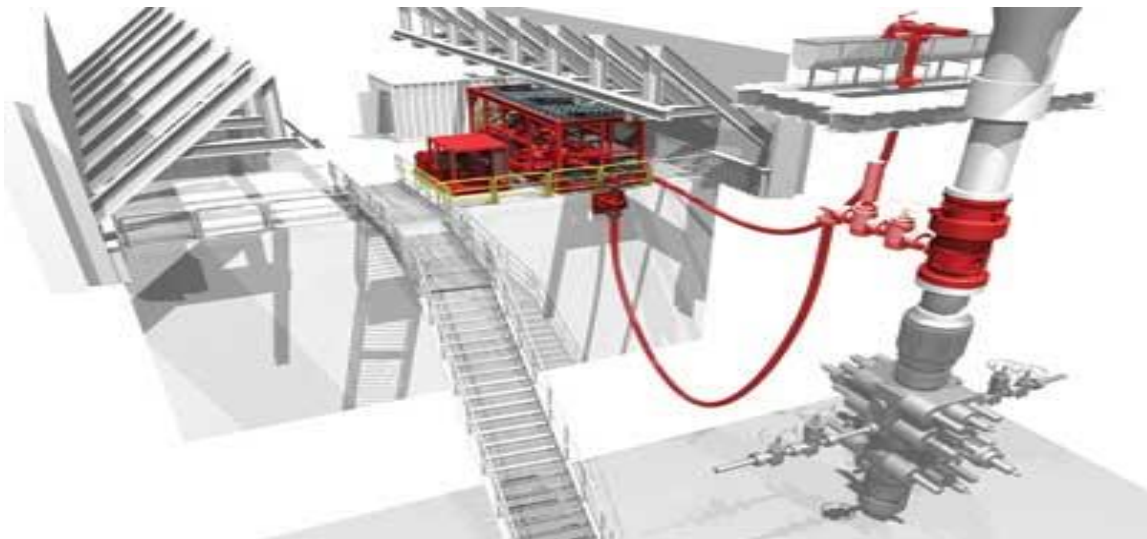

Figure 87 Underbalance system

6.5.3.2 Coiled-Tubing Systems

Well control is much simpler when drilling with reeled systems. A lubricator can be used to stage in the main components of the BHA, or if a suitable downhole safety valve can be used, then a surface lubricator is not required.

6.5.3.3 Rotating Diverter Systems

The principle use of the rotating diverter system is to provide an effective annular seal around the drill pipe during drilling and tripping operations by packing off around the drill pipe.

There are currently two types of rotating diverter: **Active and passive**

6.5.3.3.1 Rotating Control Heads (Passive Systems)

Uses external hydraulic pressure to activate the sealing mechanism and increase the sealing pressure as the annular pressure increases.



Figure 88 Rotating diverter system

6.5.3.3.2 Rotating BOPs (Active Systems)

The rotating blowout preventer (RBOP), as it is commonly referred to under its trade name, is probably the most significant piece of equipment developed, with the biggest impact being its ability to drill underbalanced with jointed pipe in a variety of different reservoir and wellbore scenarios. The rotating control-head system must be sized and selected based on the expected surface pressures.

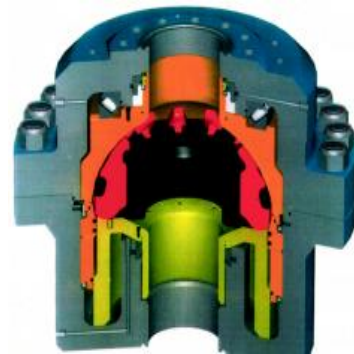

Figure 89 Rotating BOP's

6.5.4 Surface Separation Equipment

The separation system must be designed to handle the expected influx, and it must be able to separate the drilling fluid from the return well flow so that it can be pumped down the well once again.

The surface separation system in UBD can be compared with a process plant, and there are many similarities with the process industry. Fluid streams while drilling underbalanced are often described as four-phase flow because the return flow comprises of oil, water, gas, and solids.

6.6 UNDER BALANCED DRILLING TECHNICAL LIMITATION

6.6.1 Wellbore Stability

Wellbore stability is one of the main limitations of UBD. Borehole collapse as the result of rock stresses is one issue to consider. The other issue is chemical stability, which is a problem seen in shale and clay stone formations. Both these issues can have serious implications in UBD. Defining maximum drawdown and reviewing chemical compatibility with the proposed drilling fluids is a key issue in the feasibility of UBD.

6.6.2 Water Inflow

If the flow rate is high enough, the well will be killed because of the water influx. Gas lifting a well that produces water at a high rate is almost impossible.

6.6.3 Directional Drilling Equipment

Hydraulic operated tools cannot be used in underbalanced wells, and if a gasified system is used, the MWD pulse systems may not work. Certain motors and other directional equipment may be prone to failure because of the rubber components becoming impregnated with the gas used.

6.6.4 Unsuitable Reservoir

The reservoir may not be suitable for UBD. A highly porous, high-permeability reservoir can provide too much inflow at low drawdown. It is important that the perceived benefits of UBD are kept in mind when planning for underbalanced operations.

6.6.5 Safety and Environment

The health, safety, and environment issues of a UBD operation may prove to be too complicated to allow UBD to proceed.

6.6.6 Surface Equipment

The placement of the surface equipment may prove to be impossible on some offshore locations. There can be problems with rig-floor height and with deck space or deck loading.

6.6.7 Personnel

The number of crew required for UBD is still considered large; 15 to 20 extra crewmembers are required for full UBD and completion.

7 Managed Pressure Drilling (MPD)

7.1 OVERVIEW

Managed pressure drilling (MPD) is a drilling technology applied to unconventional prospects where conventional, hydrostatically over balanced drilling methods encounter problems.

MPD finds its greatest success in drilling plays where the margin between pore pressure and fracture gradient is very narrow.

The MPD system constitutes several skids containing manifolds, valves, and sensors that plumb into the drilling rig mud circulating system.

This system creates a closed atmosphere in the wellbore, which allows MPD technology to achieve a target equivalent circulating density (ECD) by adjusting surface backpressure across the wellhead.

Once the target ECD is reached, stable bottom hole pressure is established.

MPD allows drilling operations to continue “at balance” in oil and gas plays where primary well control cannot meet the needs of pore pressures due to weak fracture gradients in the well profile.

7.2 DEFINITION OF BASIC CONCEPTS

7.2.1 Formation Pore Pressure

The formation fluid pressure, or pore pressure, is the pressure exerted by the fluids within the formations being drilled. The sedimentary rocks, which are of primary importance in the search for, and development of oilfields, contain fluid due to their mode of formation.

7.2.2 Overburden Pressure

Overburden pressure is the pressure at any point in the formation exerted by the total weight of the overlying sediments. This is a static load and is a function of the height of the rock column and the density of the rock column.

7.2.3 Fracture Pressure

The pressure at which the formation fractures and circulating fluid is lost. Fracture pressure is usually expressed as a gradient, with the common units' psi/ft (kg/m) or ppg (kPa).

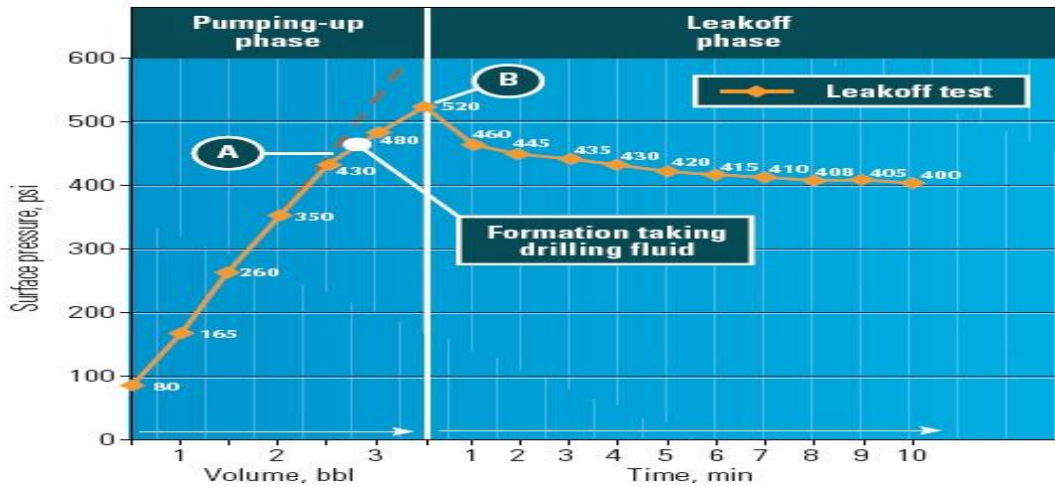

Figure 90 Leak off test

7.2.4 Hydrostatic Pressure (Ph)

Pressure of fluids present in a hydrocarbon reservoir. This pressure is usually exerted by a column of water on sea level from the depth of a hydrocarbon reservoir inside the earth's surface.

7.2.5 Bottom Hole Pressure (BHP)

Pressure exerted by a column of fluid at the base of the wellbore.

7.3 CONVENTIONAL DRILLING METHOD

In conventional drilling operations, drilling fluid is circulated down the drill string and out of the wellbore through an open flow line above the blowout preventer (BOP).

As result, the annulus is exposed to atmospheric pressure, during such operations wellbore pressure is most commonly controlled by adjusting the density and viscosity of drilling fluid, pump rate and cutting load by adjusting the rate of penetration (ROP) in doing so, drilling engineer can adjust annulus circulating friction and hydrostatic pressure to allow the wellbore to remain between pore & fracture pressure.

Wellbore pressure should be kept high enough to maintain well control and wellbore stability and low enough to avoid lost circulation, reduce stuck pipe event and prevent inefficiencies in bit performance, satisfying these constraints keeps wellbore pressure in an optimized range while drilling.

$$P \text{ formation} < P \text{ stability} < P \text{ wellbore} < P \text{ inefficient ROP \& stuck pipe} < P \text{ fracture}$$

Since adjusting fluid properties require time & effort, conventional drilling operations have a limited capacity to address dynamic operational challenges that are the result of known and unexpected influx, lost circulation, stuck pipe can cause significant Non-productive time (NPT) during drilling operations.

In the event of an influx, traditional well control methods require time to perform shut down, possibly perform a flow check, and finally shut-in blow out preventer (BOP).

During this procedure, bottom hole pressure (BHP) falls due to a loss in circulation friction and the well continues to take additional influx until the BOP is finally shut-in, despite the drop in bottom hole pressure (BHP) and time needed to execute the above operations, the conventional method is robust in terms of ease in which rig personnel can be trained to execute these operations.

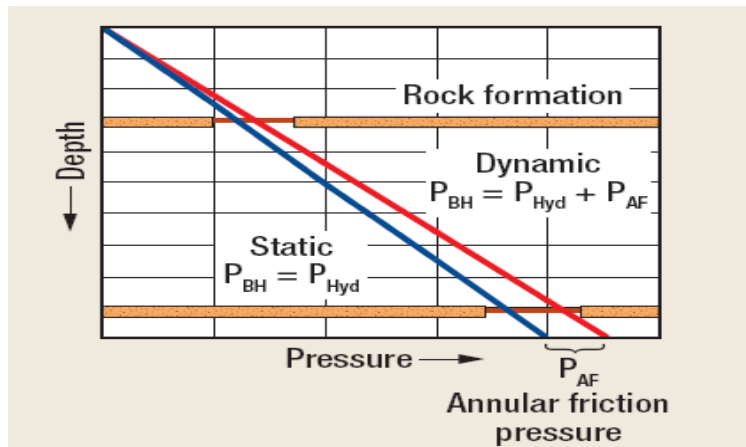

Figure 91 Static Pressure Vs. Dynamic Pressure

7.4 HOW TO MANAGE PRESSURE

The pressure profile in the wellbore can be managed by several techniques. For convenience we can divide this section into two stages:

- 1- Varying the 'Conventional Pressure Management' parameters and
- 2- Managing/optimizing the MPD parameters.

7.4.1 Managed Pressure Drilling Definition

The International Association of Drilling Contractor (IADC) defines managed pressure drilling as follows:

"MPD is an adaptive drilling process used to more precisely control the annular pressure profile throughout the wellbore, the main objectives of managed pressure drilling "MPD" are to ascertain the down hole pressure environment limits and manage the annular hydraulic pressure profile accordingly.

7.4.2 MPD Benefits

The primary purpose of MPD is to enhance well construction by minimizing drilling problems, with reservoir benefits a secondary advantage. As a drilling solution, MPD can improve ROP and extend bit life, as well as minimize differential sticking and lost circulation. Able to drill narrow pressure margins efficiently and safely, MPD can reduce the number of casing strings required and allow integration of MWD/LWD, directional, engineering, and mud logging services by maintain bottom hole pressure slightly above or equal to reservoir pore pressure.

- Mitigate drilling hazards such as fluid loss, differential sticking, kicks, and lost circulation.
- Optimize rate of penetration and prolong bit life to enhance drilling efficiency.
- Reduce the number of casing strings from conventional drilling techniques.
- Minimize the number of mud changes to the target depth.
- Minimize health, safety, and environmental risks.
- Enable the completion of otherwise un drillable well.
- Extend the conventionally-viable depth of existing projects.
- Reduce the downtime / NPT issues.
- Provide well-over-well drilling consultation and optimization.

7.4.3 Narrow Pressure Windows

Narrow pressure windows are a challenge commonly encountered in many deep-water wells. The slightest excess or lack of wellbore pressure can mean the difference between success and failure with conventional drilling.

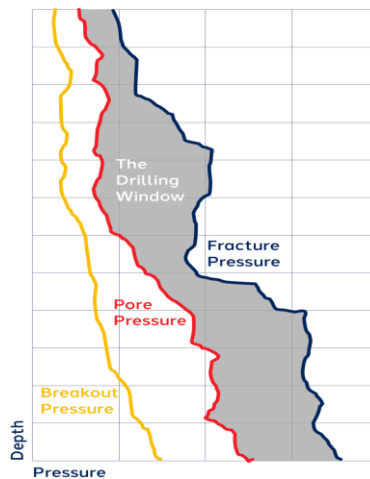

Figure 92 Drilling window

One solution to this problem is the use of MPD systems with hydrostatically underbalanced drilling fluids to be able to decrease the ECD to a point that will allow the well to be drilled to the planned depth without experiencing loss of circulation.

7.4.4 Managed Pressure Drilling Techniques

There are four key variations of MPD. Each is addressed in the context of the drilling hazards to which it has proved applicable.

7.4.4.1 *HSE OR Returns flow control (RCF).*

- Enclosed wellbore vs. open to atmospheric system.
- Diverts flow away from rig floor, avoids closing the BOP Allows pipe movement whilst killing the well.

7.4.4.2 *Mud Cap Drilling (MCD).*

Mud cap drilling defined as a sacrificial fluid used to drill Cap fluid to maintain well control, Offset wells have experienced total losses or near total losses.

- Pressurized Mud Cap Drilling (PMCD).
- Floating Mud Cap Drilling (FMCD).
- Controlled Mud Cap Drilling (CMCD).

7.4.4.3 *Constant Bottom Hole Pressure (CBHP).*

Offset wells have experienced Narrow Margins, kick losses scenarios, ballooning, "breathing", "high ECD", wellbore instability, surface pressure applied to maintain bottom hole pressure Well closed in on connections ECD compensated.

- Friction Management Method.
- Continuous Circulation Method.

7.4.4.4 *Dual Gradient (DG).*

- Annulus Injection Method.
- Riser less Dual Gradient Method.
- Two fluid gradients used to control the well mainly associated with Deepwater.
- Light fluids or solids injection into casing or marine riser.

7.4.5 Limitations of MPD

- Limited space avoids using specific MPD equipment and downsize them.
- Difficulties in control of pump ramp speed and movement of the pipe when connection.
- Sacrificial fluid must be available or reserve in large quantity.
- MPD operations involve specialized and trained operators.
- Surplus in regulatory requirements, logistic, reparation and planning.
- Two or more techniques must be applied to meet some situation.

7.4.6 Managed Pressure Drilling Tools

key tools for most techniques of MPD are;

7.4.6.1 *Rotating Control Device on Floating Rigs (wave heave)*

- External Riser RCD.

- Subsea RCD.

- Internal Riser RCD (IRRCH).

7.4.6.2 *Rotating Control Device on Fixed Rigs (no wave heave)*

- Passive & Active annular seal design “land” models

- Marine Diverter Converter RCD

- Bell Nipple Insert RCD

- IRRCH (in marine diverter or surface annular)

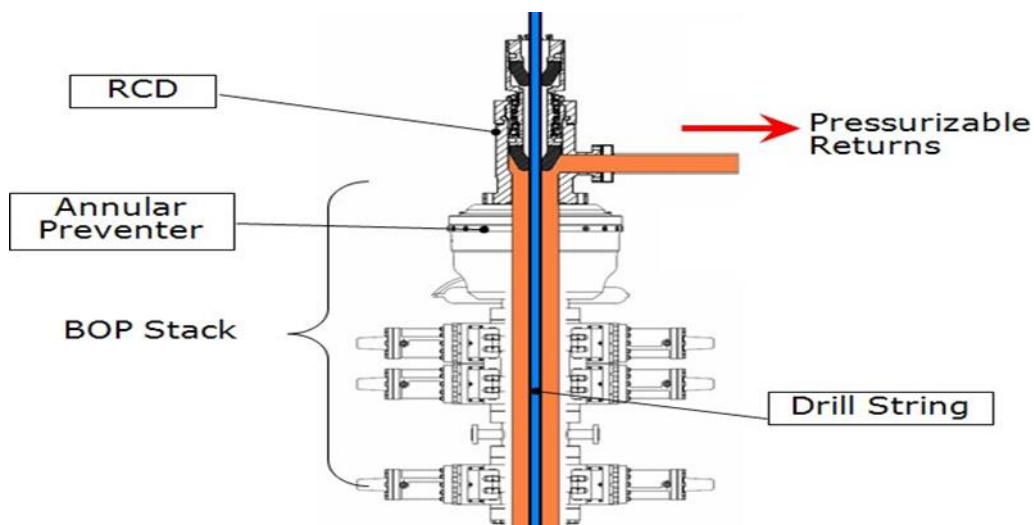

Figure 93 Rotating control device (RCD)

7.4.6.3 *Non-Return Valves*

Float valves are necessary for MPD to prevent influx of reservoir fluids inside the drill string either when tripping or making connections.

7.4.6.4 *Choke Options (dedicated recommended, except HSE)*

- Manual.

- Semi-automatic.

- PC Controlled Automatic.

8 WELL COMPLETION

8.1 OBJECTIVES

After studying this section, the trainees should be able to perform the following:

- Describe the function of well completion operation in well servicing.
- Describe the function of all components of the Rig Up equipment.
- Describe the preventive maintenance.
- Describe the operational procedures.
- Describe the rig up/rig down procedures related to well completion.
- Describe completion operator's general safety precautions and emergency response procedures.

8.2 OUTCOMES

Upon completing their training, the participants should be able to:

- Execute written and verbal instructions and effectively exchange information with peers and superiors.
- Perform basic mathematical calculations and basic reading comprehension and writing skills.
- Demonstrate proficient knowledge of the well completion and related products.

8.3 OVERVIEW

While many important procedures are involved in the successful production of oil and gas from a petroleum reservoir, probably none is more important than the actual completion of the well.

After a well has been drilled, there is only one opportunity to complete it properly. The completion affects all subsequent events during the entire producing life of the well.

The fluid used during the completion of a well has a significant impact on preserving the potential for satisfactory production. It is critical to match the completion method and fluid requirements with the formation characteristics. Completing a well is essentially preparing it to produce oil and/or gas.

The most common completion method is made up of the following steps:

- 1- The production casing is run into the well and cemented.
- 2- Flow-control valves are installed at the wellhead, and production tubing is run into the well and sealed inside the casing with a packer.
- 3-The well is perforated opposite the producing zone and production begins.

A typical well completion includes the following subcomponents:

1. A wellhead assembly which seals and controls well pressure and flows at the surface (valves, spools and flanges).

2. A casing and tubing arrangement to provide zonal isolation and allow fluids to flow from the producing zone to the surface.
3. A bottom-hole completion assembly which seals and provides control over the producing zone.

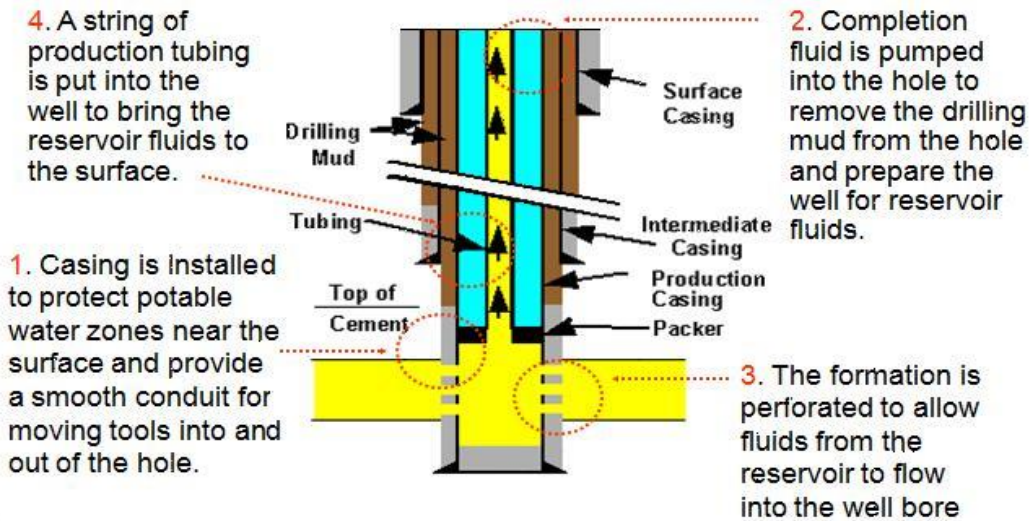

Figure 94 Typical well completion diagram

8.4 COMPLETION DEFINITION

The completion operation is defined, as all the operation required to complete the well after finishing the drilling to produce the well in a safe way.

8.5 TYPES OF COMPLETION

The completion can be classified based on three criteria.

1. The interface between the wellbore and the reservoir.
2. The production method.
3. The number of zones completed.

The interface between the wellbore and the reservoir.

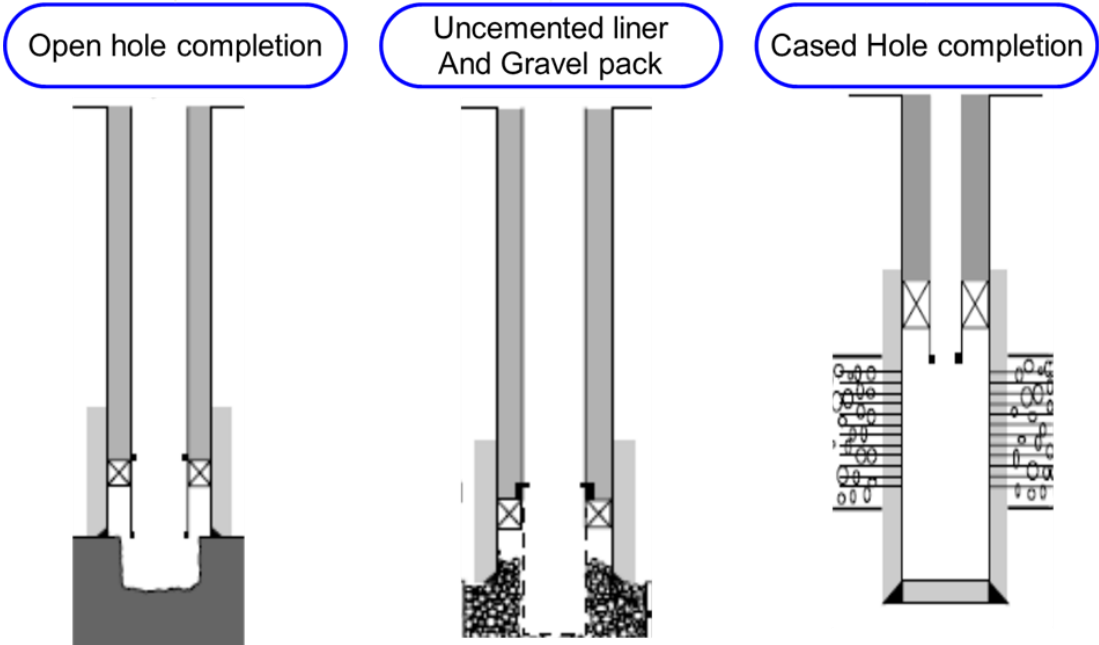

Figure 95 Wellbore interface completion types

Production Method

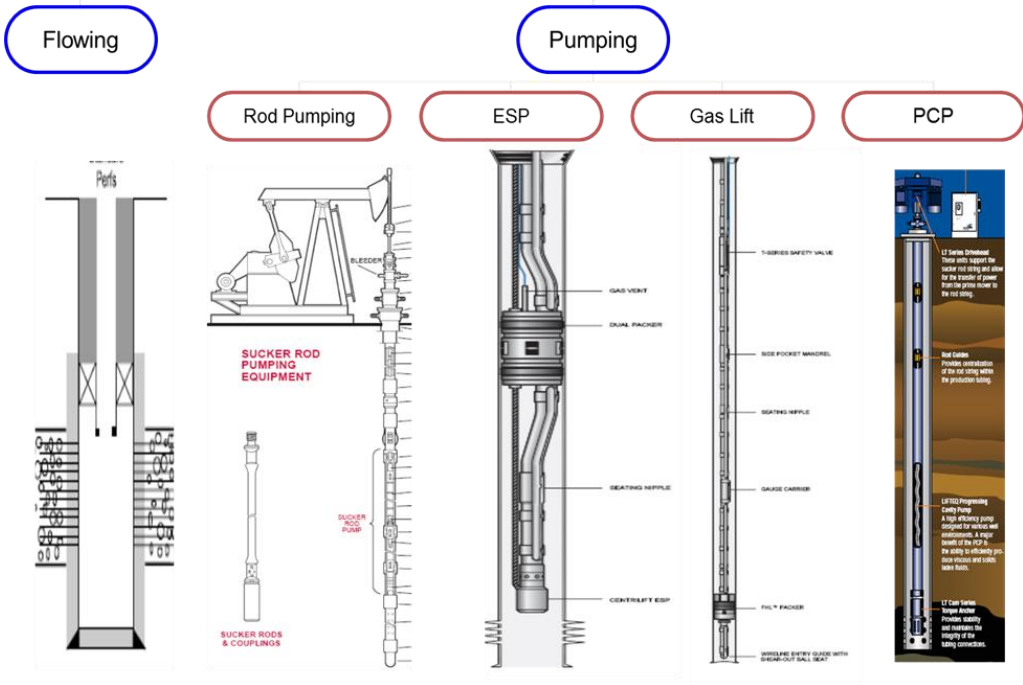

Figure 96 Production method completion types

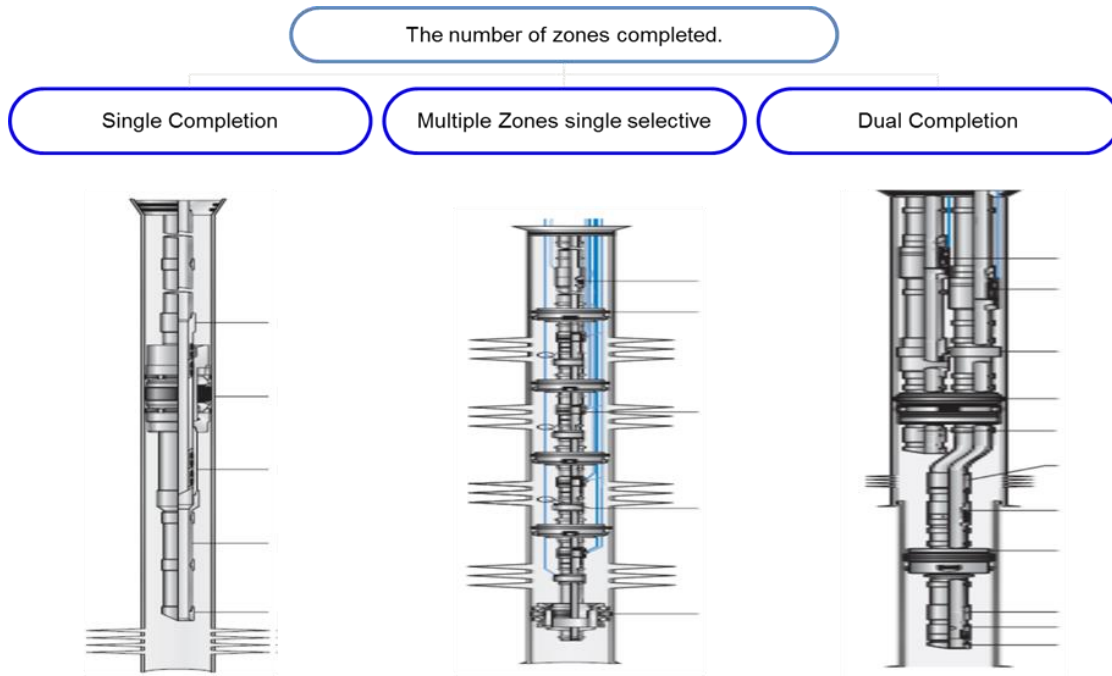

Figure 97 Zonal Production methods

8.6 WHY WE NEED TO PERFORATE THE WELL?

The perforation is needed to:

- 1) To open pass for the oil through the casing.
- 2) To the cemented and damaged zone behind the casing.

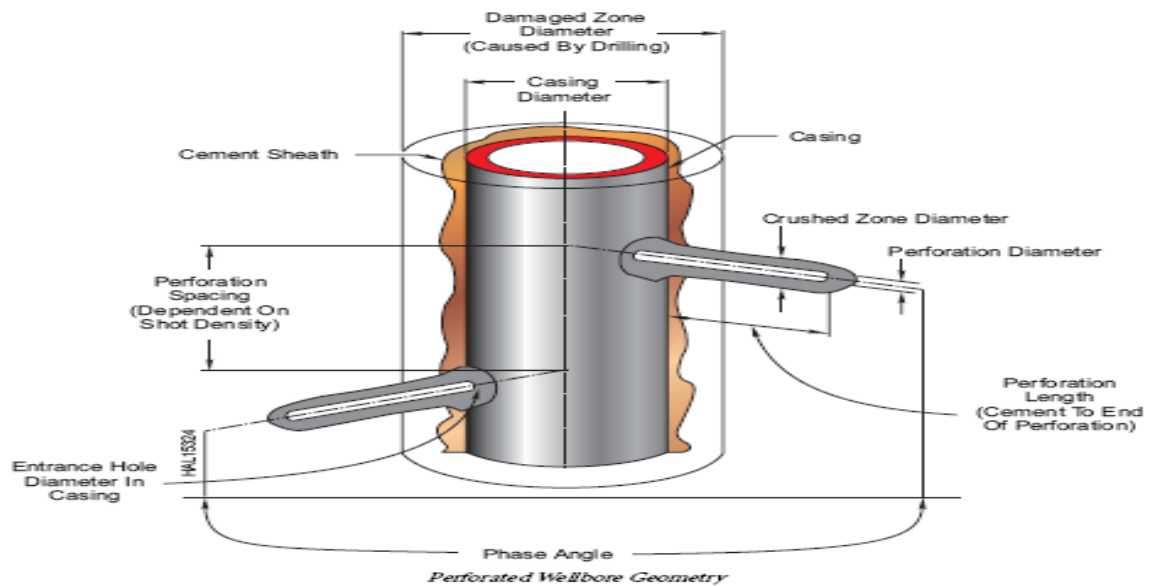

Figure 98 Perforation operation

8.7 FACTORS INFLUENCING WELL COMPLETION SELECTION.

- Natural occurrences of the field, i.e. does it have a big reserve to justify development?
- Potential of oil production and the planning of tertiary recovery, i.e. do we need any artificial lift in the future?
- Limitations within the operation and the field, i.e. is the oil field located at a remote area?

8.8 TYPE OF FLOW

Three types of flow, namely casing flow, tubing and annulus flow, and tubing flow.

- ❖ **Casing Flow:** Large flow rate. No tubing is required.
- ❖ **Tubing and Annulus Flow:** Large flow rate.
- ❖ **Tubing Flow:** Used widely due to safety. May use one tubing string or more.

8.9 COMMON COMPLETION EQUIPMENTS

Picture show a typical example of a simple and versatile design. The equipment used in this completion is in common use, the specific applications and uses are outlined in the sub-sections herein.

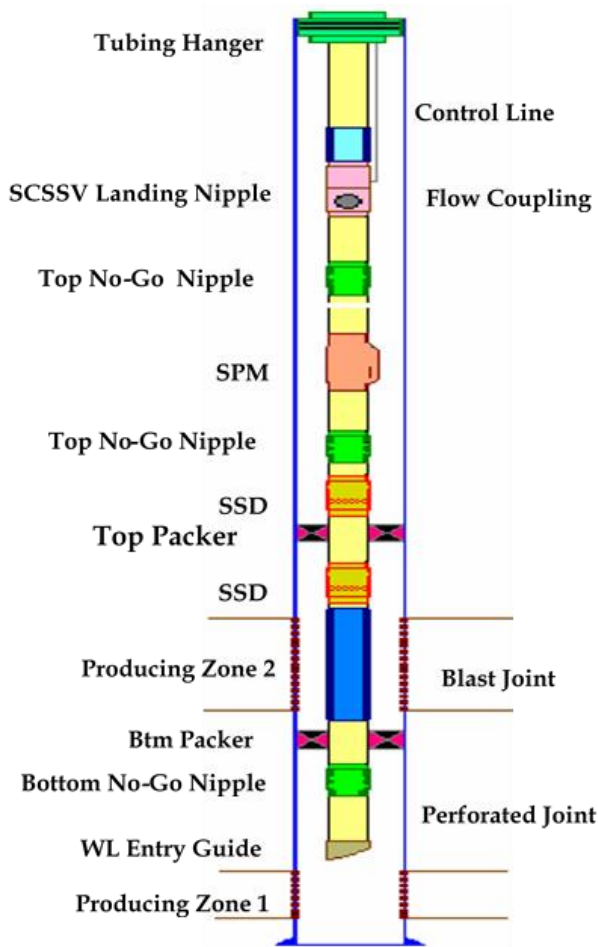

Figure 99 Common completion equipment

8.9.1 Well head/X-Mass Tree

The wellhead provides the basis for mechanical construction of the well at surface or the sea bed.

It provides for:

1. Suspension of all individual casings and tubular in the well.
2. Ability to install a surface closure / flow control device on top of the well.

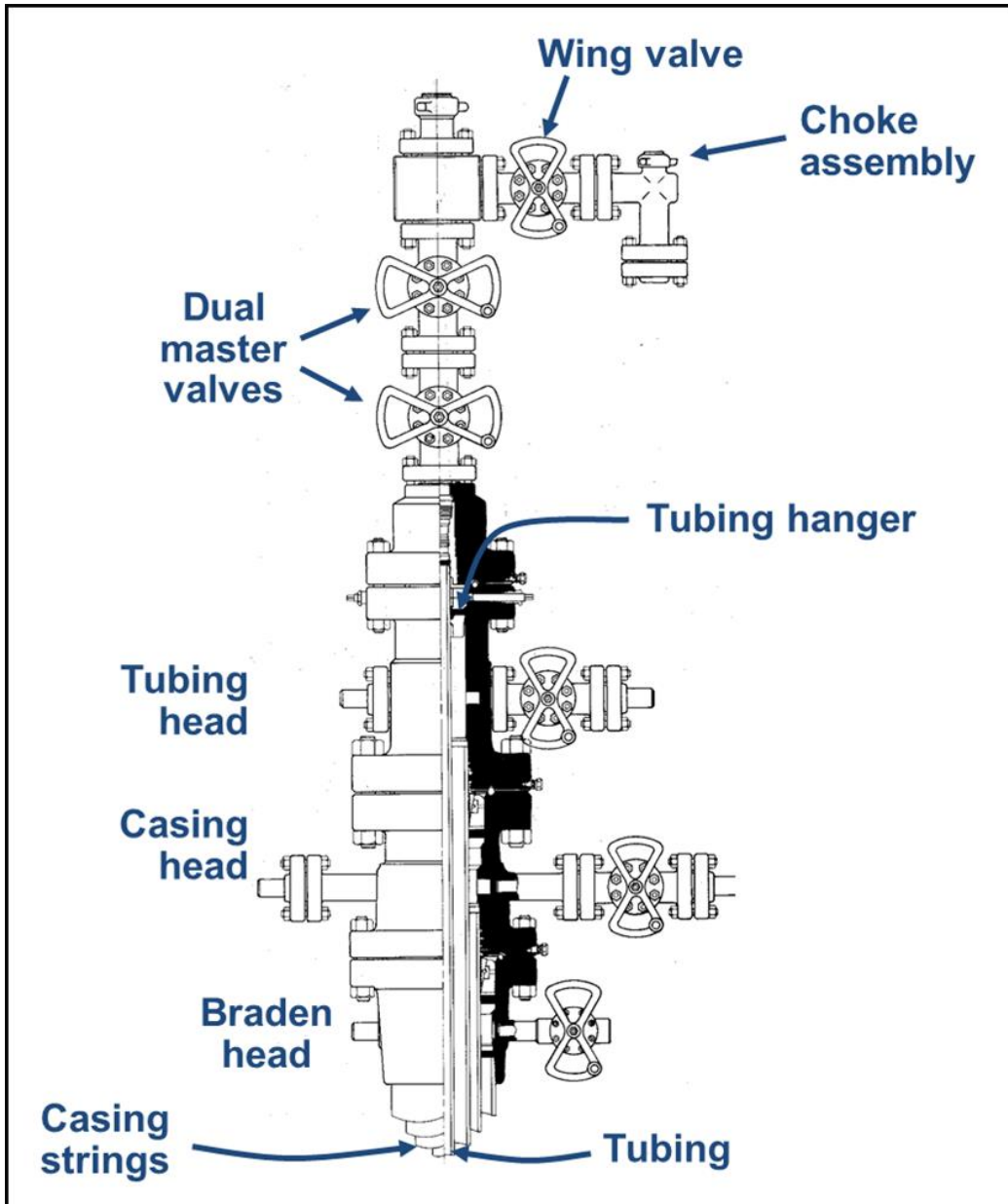

Figure 100 Well head

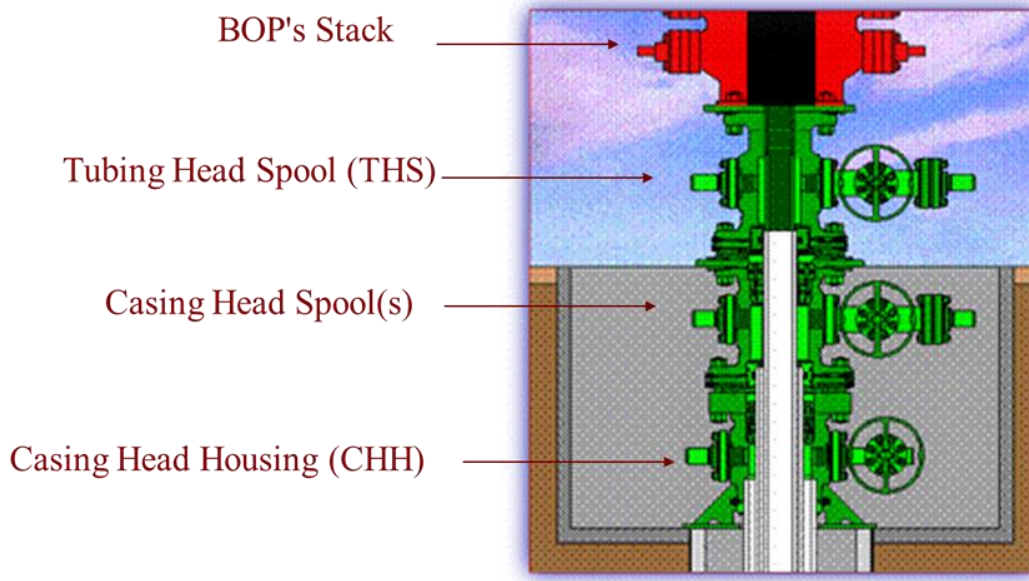

Figure 101 Well head configuration

8.9.2 Production Tubing

When selecting production tubing, the following data must be specified:

1. The grade of steel selected for the manufacture of the tubing. N80 , L-80 etc . Will be dependent on several factors such as the strength requirements for the string and, the possible presence of corrosive components such as CO₂ or H₂S.
2. The wall thickness of the tubing must be specified based on the difference between internal and external pressures.
3. The threaded coupling is an important part of the design specification as it defines both the tensile strength and the hydraulic integrity of the completion string, threads commonly selected for production tubing are EUE, VAM, VAM-TOP etc.

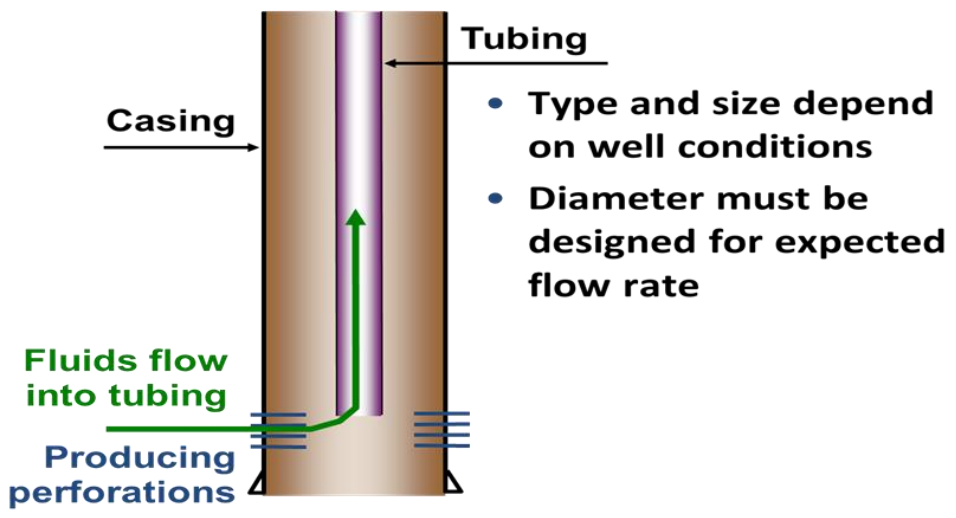

Figure 102 Production tubing

8.9.3 Production Packer

The function of the production PKR is to seal the flow in the tubing/CSG annulus, and use for one of the following reasons:

1. To improve flow stability and production control.
2. To provide the facility to select or isolate various zones during stimulation or production, e.g. to isolate two producing zones having different fluid properties, GOR, pressure or permeability (especially relevant for injection) or to stimulate or pressure maintenance.

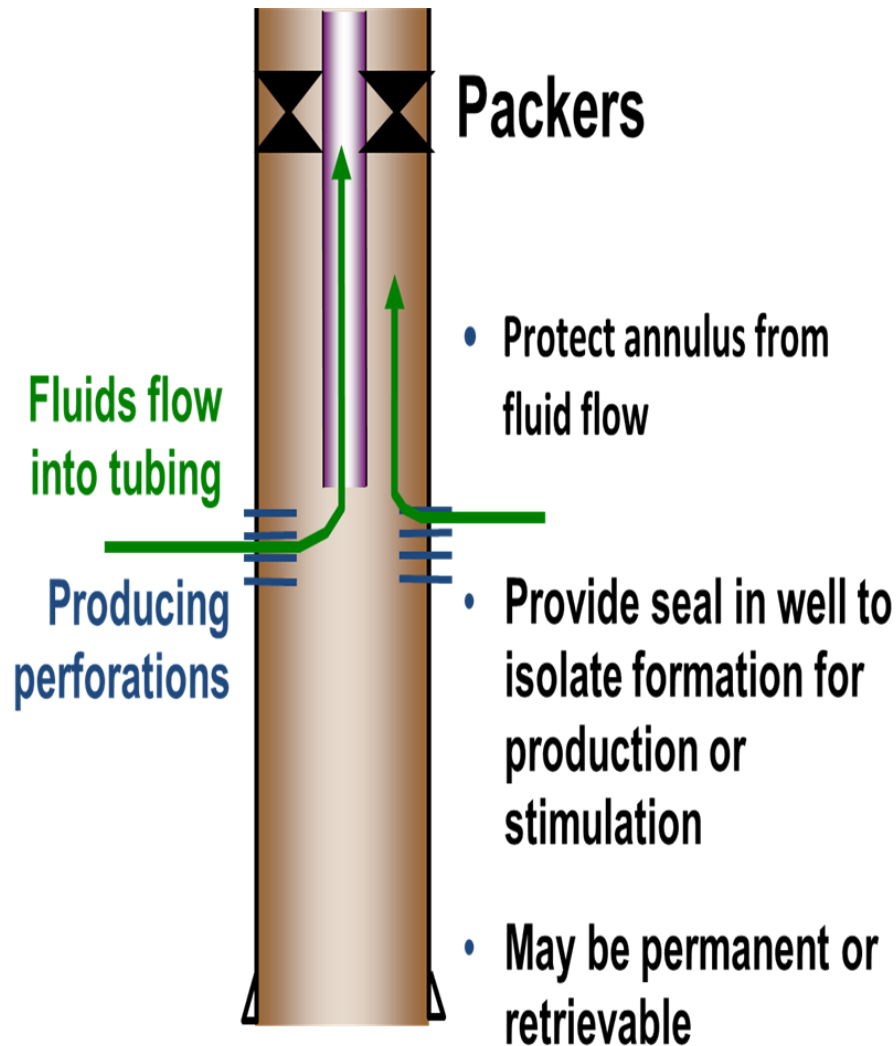

Figure 103 Production packer

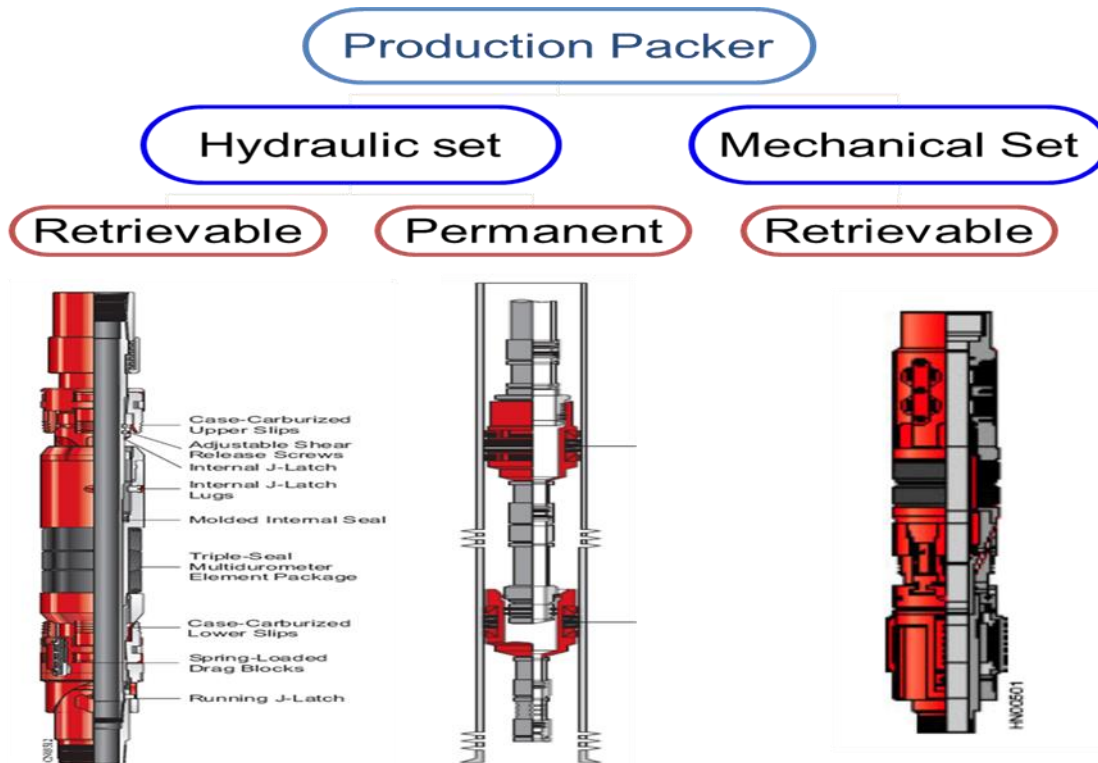

Figure 104 Production packer types

The main completion production packer types available are:

8.9.3.1 *Permanent*

A type of packer usually distinguished by its high pressure and temperature ratings, large bore, and its requirement to be milled-out' in order to retrieve it from the well.

8.9.3.2 *Retrievable*

Have the advantage of being able to be retrieved from the Well by a straight pull of circa 40,000lbs. Usually these packers will have lower pressure/temperature ratings and possibly smaller through bores.

8.9.4 TUBING ANCHOR CATCHER.

The function the TAC is to anchor the TBG to prevent TBG movement in the sucker rod completion.



Figure 105 Tubing Anchor catcher

8.9.5 Landing Nipple

A landing nipple is a short tubular device which has an internally machined profile capable of accommodating and securing a mandrel run into its bore on wireline or coiled tubing.

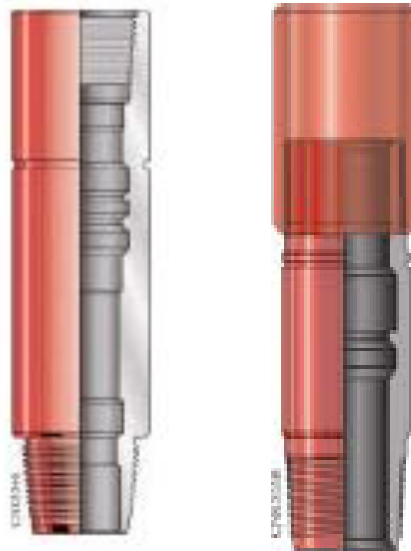

Figure 106 Bottom No-Go/ Top No-Go

Nipples are installed at various points in the string to Plug the tubing for:

- 1) Pressure testing.
- 2) Setting hydraulic set packers.
- 3) Zonal isolation.

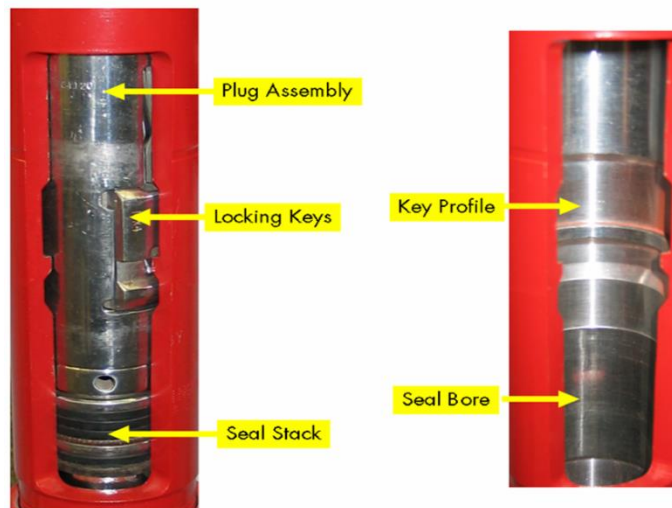

Figure 107 Nipple with plug set

8.9.6 Slide Side Door (SSD)

The function of the SSD is to open or close the flow from the annulus to the tubing selectively.



Figure 108 Slide side door" SSD"

8.9.7 Control Line

Control line is normally a ¼ inch OD Monel or stainless-steel tubing, connected between the safety valve nipple (or tubing retrievable valve) and the tubing hanger. The control line is secured to the tubing by clamps (these may be steel or plastic). It is the conduit used for the supply of hydraulic pressure from the surface control panel to the safety valve.

8.9.8 Sub-Surface Safety Valve (SSSV)

The function of the SSSV is to close the well from sub-surface by using hydraulic control.

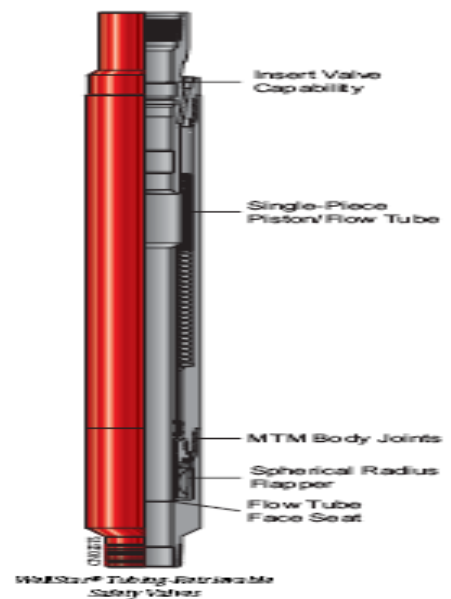

Figure 109 Sub surface safety valve

8.9.9 Side Pocket Mandrel (SPM)

Pocket with ports into this component, contains an off-Centre annulus and can be used as a pocket for:

1. Gas Lift valves.
2. Chemical Injection Valves.

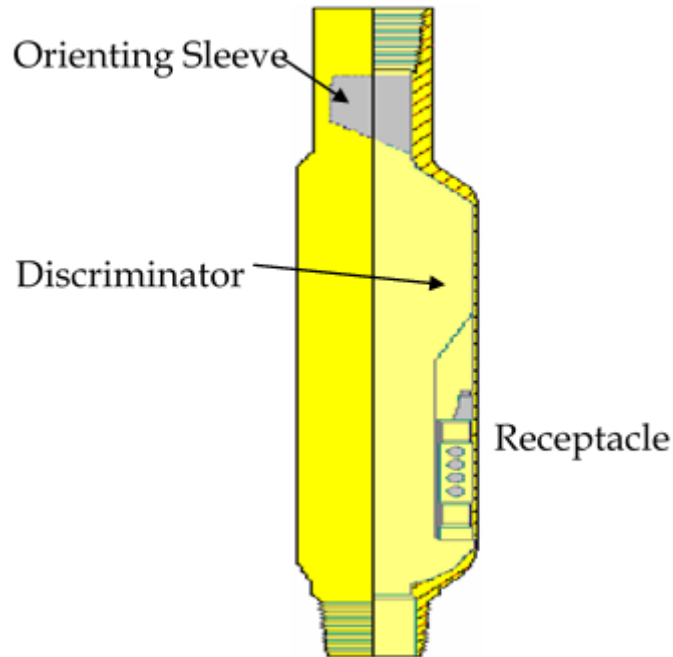

Figure 110 Side pocket mandrel (SPM)

8.9.10 Polished Bore Receptacle (PBR)

Polished Bore Receptacle is a device that is honed the internal diameter of sealing surface, it is mainly used in tieback casing and for landing production casing seal assembly. The seal receptacle is attached to the top of the packer. The seal assembly, which mates with the PBR, is attached to the bottom of the tubing string. The function of the PBR is to allow travel upwards and downwards within the PBR to cater for tubing movement due to expansion or contraction of the tubing caused by temperature increase/decrease, ballooning and piston effects. Sometimes the seals are attached to the PBR with shear-pins or a shear-ring in order that the completion can be installed in one trip. The shear pins or shear ring can then be hydraulically or mechanically sheared to allow travel, after the packer has been set. The major advantage of Polished Bore Receptacle is to provide a seal bore above liner.

8.9.11 Flow Coupling

When flowing a high rate well, the fluid will move at extremely high speed. when meeting a restriction, such as a nipple profile, excessive turbulence will develop immediately above the nipple causing excessive erosion. To cater for this excessive erosion, a 6 ft joint of heavy walled tubing would be installed above (and sometimes below) the nipple. Although the same amount of erosion will be experienced, the added wall thickness of the flow coupling will leave enough material intact to prevent any leakage and maintain tensile strength during the life of the well.

8.9.12 Tubing Hanger

The tubing hanger supports the weight of the completion string in the wellhead and seals between the tubing/Xmas tree bore and the annulus.

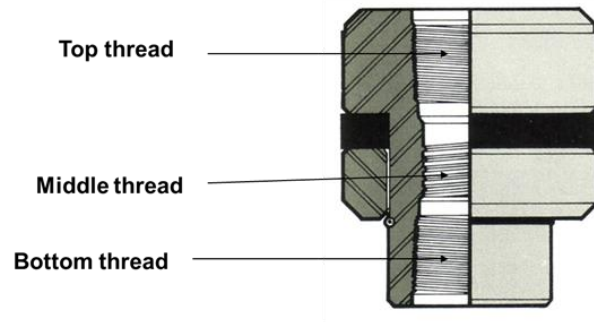

Figure 111 Tubing Hanger

The tubing / casing annulus is the space between the ID of the casing and OD of the tubing above the packer. It is usually filled with fluid such as water, mud or brine. This fluid usually contains a corrosion inhibitor which protects the tubing and casing from corrosion.

As it is always the tubing in which the wire line operations are carried out, it is necessary for the wire line operator to know the following facts about tubing.

8.9.13 Blast Joint

Fluids entering perforations may display a jetting behavior. This fluid-jetting phenomenon may abrade the tubing string at the point of fluid entry, ultimately causing tubing failure.

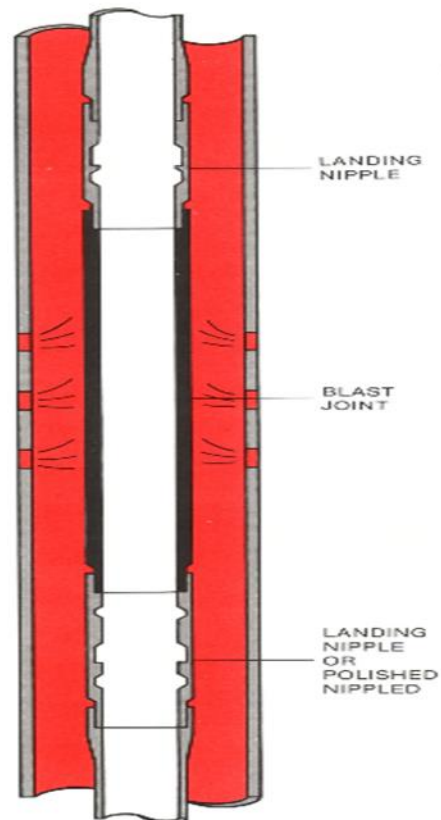

Figure 112 Blast Joint

8.9.14 Wire Line Entry Guide (WLEG)

It is used in the tail of the TBG to allow easy re-entry of well intervention string as slick line, E/L and CT.

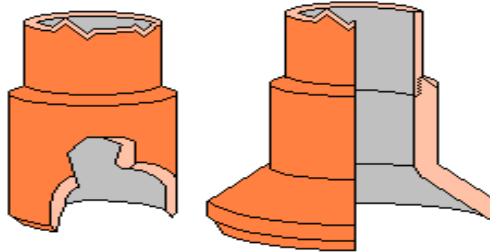

Figure 113 Wire line entry guide (WLEG)

8.9.15 Perforated Pup Joint

- It may be included in the string for purpose of providing by pass flow if bottom hole pressure and temperature are used for reservoir monitoring.
- The design criteria in perforated pup joint is that the total flow area is not less than the cross-sectional area of the TBG.
- In wells having large flow volumes, a restriction in the tubing such as a gauge hanger, may hold some back pressure causing false pressure recordings. Vibration due to flow turbulence may also cause extensive damage to the gauges, therefore a perforated pup joint (approximately 8 ft long) is installed above the gauge hanger nipple, this allows flow to pass unrestricted around the gauges and hangers, providing accurate pressure/temperature recordings with the limits of the gauge. The total area of the perforations must be greater than the ID of the pup joint (generally 3-4 times the area).

Perforated flow tube

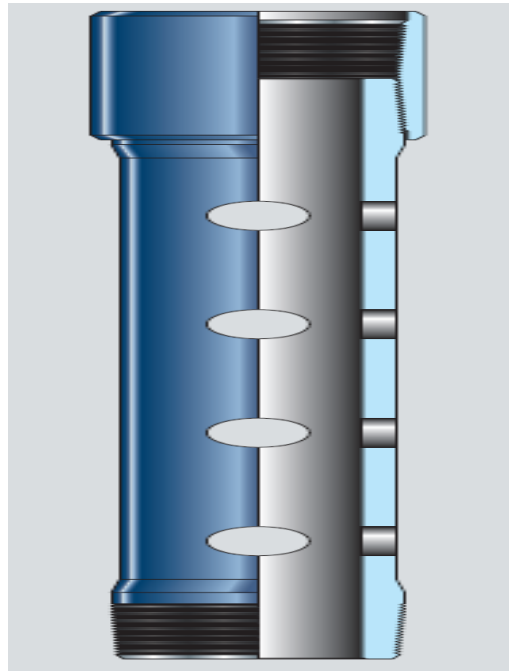
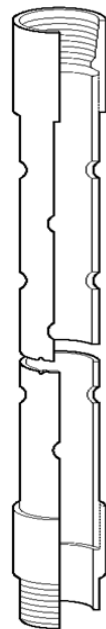

Figure 114 Perforated Pup joint

8.9.16 Pup Joint

It is a short TBG pipe from the same material and specification as the main TBG pipes but has different lengths used in space out operations when positioning of completion equipment is critical as perforation gun or PKR depth or sting in top of PKR.

8.9.17 Cross Over

A crossover is a connector which fits between two different sizes or types of threaded connections. For instance, between 4 ½ inches to 5 ½ inches or 3 inches to 4 inches tubing, etc.

9 WIRELINE, SLICKLINE, WIRELINE LOGS and PERFORATIONS

9.1 OBJECTIVES

After studying this section, the trainees should be able to perform the following:

- Describe the function of wireline operation in drilling and workover.
- Describe the function of all components of the Rig Up Equipment.
- Describe the operational procedures.
- Describe the rig up/rig down procedures related to wireline.
- Describe wireline operator's general safety precautions and emergency response procedures.

9.2 OUTCOMES

Upon completing their training, the participants should be able to:

- Execute written and verbal instructions and effectively exchange information with peers and Superiors.
- Demonstrate knowledge of all wireline services and related products.
- Demonstrate proficient knowledge of the wireline tools and related products.

9.3 OVERVIEW

Through all stages of drilling, testing, completion and production, wireline procedures will be used extensively for workover, data gathering and operational requirements. Modern wireline techniques and equipment have developed and improved enormously as the whole oil industry itself has developed. Originally, wireline was conceived as an early method of determining the depth of a well accurately, by lowering a flat section, graduated steel tape into the well from a hand-operated reel.

As depths increased, the difficulties associated with this technique grew until it was no longer safe or practicable. The tape was replaced by a circular section of slickline or measuring line, which allowed superior sealing properties when the survey was performed under well pressure.

The line was marked in equal increments and calibrated measuring wheels introduced. These 'Veeder Root' counters are very similar to those in use today. Larger diameter lines were introduced as new demands on the line, such as removal of deposits; installation and removal of flow control devices were made.

The grade of solid steel line has progressed to the modern line in use today of +25,000 ft. length and extremely high tensile strength.

Downhole equipment was now being designed with the greater wireline capability in mind. This equipment included tubing plugs, to enable the tubing to be run and pulled under pressure, bottom hole chokes for gas wells to prevent freezing of surface flow lines caused by choking at the surface, running straight hole survey instruments, known as 'syphon' and operation of the first regulated gas lift valve, known as the Nixon valve. The Nixon valve was opened by upward movement of the slickline, controlled at the surface by timing devices. As the wireline was pulled upward, tools attached to the lower end opened the valve, allowing the gas to enter the tubing from the annulus. This early method of gas lift operations was followed by gas lift valves which could be removed and repaired or adjusted and reset using wireline tools.

The wireline winch unit has developed from a hand-operated reel or motor, driven from the rear axle of a car, to the modern skid-mounted, self-contained module, driven electrically, mechanically or hydraulically and fully equipped with tools and wellhead equipment to safely service gas or oil wells under pressure.

Wireline may be referred to by several names. Solid single strand line may be described as:

- Slickline
- Wireline.

Multistrand wirelines are usually described as braided line.

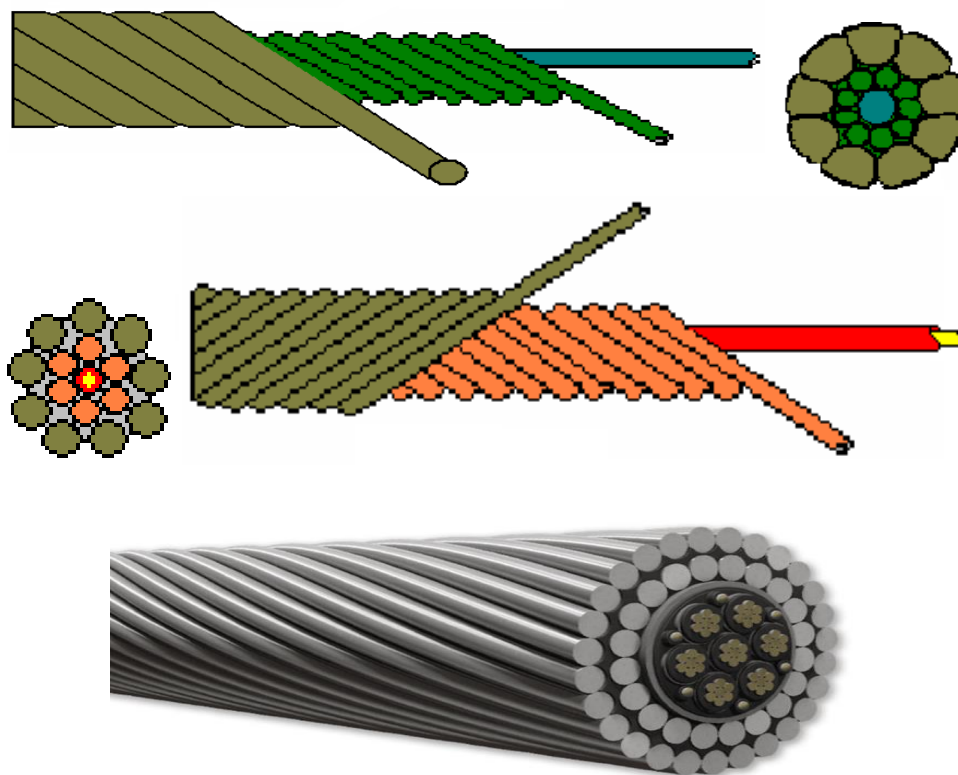

Figure 115 Wireline

As well depths have increased over the years since the first measuring lines were brought into use, accompanied by increased working loads, it has become necessary to develop wireline having a high strength/weight ratio.

There is a need for strength to accomplish the operation without the wire breaking, and a need to keep the diameter of the wire as small as possible for the following reasons:

- It reduces the load of its own weight.
- It can be run over smaller diameter sheaves and wound on smaller diameter spools or reels without overstressing by bending.
- It keeps the reel drum size to a minimum.
- It provides a small cross-section area for operation under pressure.

The sizes of solid wireline in most common uses are: 0.092ins 0.108ins and 0.125ins diameter, and are obtainable from the drawing mills in one-piece standard lengths of 18,000, 20,000, 25,000 and 30,000 ft. However, due to advances in Wireline unit counter-heads leading to more accurate depth correlation, 0.142ins and 0.160ins wirelines are also obtainable for running heavier loads such as packers and perforators. The most popular material for wireline is improved plough steel (IPS), because of its high ultimate tensile strength, good ductility, and relatively low cost. Experience indicates that improved plough steel usually performs better than the more expensive special steel lines in low corrosive conditions- although then it must be used with an appropriate inhibitor. For Sweet Wells IPS can be used

with inhibitor for high loads and long service. For Sour Wells IPS can be used with inhibitor for high loads and short operating time. When selecting or operating with wireline, various factors, such as the following, have been considered:

- Physical properties.
- Resistance to corrosion.
- Effect of bending.
- Total stress.
- Care and handling.

Due to the H₂S content of many wells special materials such as the 'SUPA' range of wirelines have been developed and manufactured by Bridon Wire, or stainless-steel wirelines are used. Although these are not as strong as IPS, they have an excellent resistance to H₂S corrosion.



Figure 116 Wireline and Slickline truck

9.4 THE DIFFERENCE BETWEEN SLICKLINE AND WIRE LINE

Wireline truck is used to place and recover wellbore equipment, such as plugs, gauges and valves, slicklines are single-strand non-electric cables lowered into oil and gas wells from the surface. Slicklines can also be used to adjust valves and sleeves located downhole, as well as repair tubing within the wellbore.

Wrapped around a drum on the back of a truck, the slickline is raised and lowered in the well by reeling in and out the wire hydraulically.

Braided line can contain an inner core of insulated wires which provide power to equipment located at the end of the cable, normally referred to as electric line, and provides a pathway for electrical telemetry for communication between the surface and equipment at the end of the cable.

eFire-Slickline firing head system.

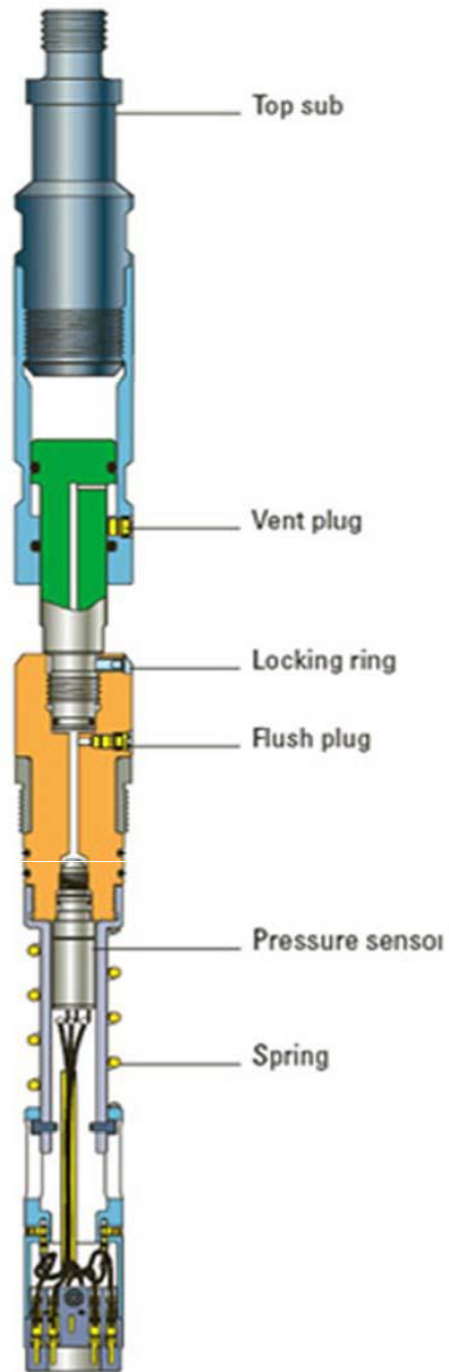

Figure 117 Slickline firing head system



Figure 118 Inside a Wireline truck

On the other hand, wirelines are electric cables that transmit data about the well. Consisting of single strands or multi-strands, the wireline is used for both well intervention and formation evaluation operations. In other words, wirelines are useful in gathering data about the well in logging activities, as well as in workover jobs that require data transmittal.

9.5 BENDING STRESSES

The bending stresses that the line is subjected to are the most common cause of breaking but are generally the least considered. Bending occurs whenever a line deviates from a straight-line condition, such as when it passes over pulleys or reel drum, or when it is flexed by hand. It is necessary to employ specific mechanical equipment, such as the reel drum, hay pulley, stuffing box pulley and measuring wheel, when carrying out wireline operations. Each time the line passes over a pulley it is subjected to two bending stresses - when it changes from a straight to a curved path and again when it reverts to a straight path. It is subject to only one when it leaves the reel drum. So, for each trip in and out of the well, the line probably suffers a minimum of fourteen bending cycles.

Note: To minimize the effect of bending stresses on the wireline, if significant jarring has been carried out, the downhole tool will be sheared off. An amount of wire equal to the complete stressed area is normally cut and discarded, and a new rope-socket is tied. Running in the Well, re-latching will allow jarring to resume with a fresh area of wire around the pulleys. This action will subject a different part of the wireline to bending stresses, thus preventing a break due to wire fatigue.

The partially pulley fatigued wire is now in the straight-line section of the wire below the Wellhead. This wire will recover most of its original ductility.

9.6 RE-SPOOLING

The life span of any wireline can be extended by using correct spooling procedures. The new wire should be spooled on to the unit drum with 250-400 lbs strain on it. Five to seven bedding wraps of carefully aligned wire are recommended to provide a firm base. This also indicates during subsequent wireline operations that only a small amount of wire remains on the drum if the wire is used to this level. With

0.125 ins wire and larger, it is becoming common practice to spool the complete drum of wire the same way as 'bedding wraps'. This method of spooling will considerably reduce the possibility of mechanical damage to the wire, which is often evident with the 'criss-crossing' method. Correct procedures for spooling new wire on a reel are shown below to minimize stress in the line. Always follow the natural curve of the wire.

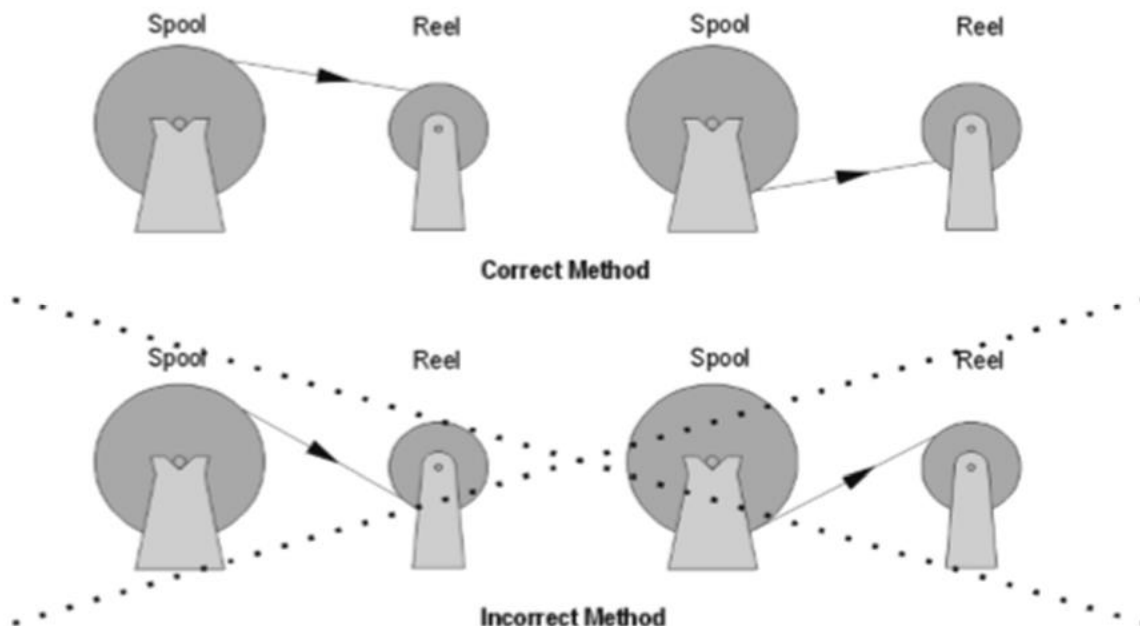

Figure 119 Sekil 1 Re-spooling

9.7 HANDLING AND STORAGE

Although steel wireline has a high strength-to-weight ratio, it still requires proper handling and storage. IPS should be stored with a lubricant covering over the surface of the wire (i.e. grease, grease paper). If not crated, wireline spools should be lifted with a nylon sling to avoid damage to the wire. When a wireline job is completed, the wire should be lubricated and covered to protect against corrosion. Oiling is preferable on used wirelines as grease can trap moisture/well fluids in the drum giving it no chance to evaporate, thus increasing the risk of corrosion. Alloy wire spools should also be kept covered, as they are not totally immune to corrosive/erosive atmospheres.

9.8 TESTING WIRELINE IN SERVICE

Regular testing of wireline in service is strongly recommended to monitor the inevitable deterioration in wire properties, and to prevent wireline failure downhole. The recommended test for API 9a and UHT wireline is the torsion test. The basic principle of the torsion test is that an 8" length of wire is twisted around its own axis until fracture occurs. The fracture is classified as 'A', 'B' or 'C'. A new wireline should give a minimum of 19 torsions to failure with an 'A' type fracture. As the line is used, the torsional ductility will gradually decrease. When less than 19 torsions are achieved, or a 'C' type fracture is obtained, then the wire should be cut back and retested until 'A' type breaks are achieved with a minimum of 19 torsions. Stainless and special alloy ductility cannot be measured using the torsion test. These alloys will always exhibit a low number of twists to failure and 'A' type fractures, regardless of wire quality. The best test for stainless wire quality is the wrap test. In this test the wire is wrapped in a tight helix around its own diameter. A new wireline should withstand 8 + wraps without signs of surface rupture.

9.9 WIRELINE FAILURE

9.9.1 Hydrogen Embrittlement

This may occur when the wireline is exposed to H₂S or CO₂ downhole. Both H₂S or CO₂ release atomic hydrogen, H (CO₂ by reacting with H₂S to form carbonic acid + H), which enters the steel and effectively 'locks' the micro-structure, thus increasing the tensile strength of the wire but reducing the torsional ductility. As the wire is withdrawn from the well, it is brittle and prone to surface cracking as it bends over the pulleys. After removal from the well environment, then eventually the hydrogen leaves the steel and reverts into the atmosphere. However, any micro-cracks incurred during withdrawal from the well remain and may cause premature failure during.

9.9.2 Age Hardening

This is a time-temperature dependent transformation potentially affecting UHT wireline due to their high internal stresses. It is known that UHT wireline is susceptible to age hardening at elevated temperatures, which is why our wire drawing machines are internally water cooled and the temperature is carefully monitored. Aging has a similar effect on the wire as hydrogen embrittlement. (i.e. The tensile strength increases, but the torsional ductility is severely impaired).

9.9.3 Fatigue

This type of failure is often encountered when operating wireline with small pulley diameters. We always recommend a pulley to wireline diameter ratio of 120:1 to ensure a reasonable fatigue life at normal working loads. It has been shown that under laboratory conditions, increasing the pulley diameter from 8" to 14" increases the fatigue life of a 0.108" diameter Supa 70 wireline loaded to 25% of its breaking load from 4,800 to 8,000 cycles (i.e. by 65%). We also advise cutting back lengths of wire to avoid localized fatigue when operating at fixed depths.

9.9.4 Corrosion

This may occur downhole or in storage if the (plain carbon) wireline is not cleaned after use.

9.9.5 Corrosion Fatigue

This occurs when there is a combination of a corrosive environment and fatigue conditions.

9.9.6 Stress Corrosion

This is a potential hazard when operating stainless wireline under heavy loads in a chloride environment. The combination of an aggressive environment and high stresses may cause catastrophic premature failure.

9.9.7 Tensile Overload

This is often experienced during heavy jarring. As explained earlier, the instantaneous shock load applied is not registered by the weight indicator and consequently, the wireline is overloaded. We recommend a safe working load of 70% of the breaking load of the wire during straight pull, with 50% of breaking load when fast jarring.

9.9.8 Snarl

This occurs when the wire is bent and twisted at one point (i.e. when a kink forms under loss of tension during respooling).

This can occur in many ways (e.g. running off a pulley, jarring in a pulley, pinching in guide rollers, or crushing of the reel).

9.9.9 Hydrodynamic Deformation

Several wirelines have been returned for investigation exhibiting 'thinning' over a short length of wire. Our examination has shown that this thinning has occurred by some form of deformation process and not by scraping or wear. No tensile test has been known to produce this effect, and indeed it is not possible to reproduce this effect in pure tension under normal conditions of temperature and pressure. Recent research has provided a theoretical model by which failure of this nature could be explained. It has been shown that the wire can be deformed by up to 30% reduction in area, by passing it through a molten polymer filled tapered tube of slightly larger diameter than the wire.

As the wire is pulled through the tube, shearing takes place at the wire polymer interface.

This shearing action gives rise to a drag force, which generates hydrodynamic pressures of enough magnitude (typically 45,000 psi) to deform the wire. A similar mechanism is thought to occur under certain circumstances when operating a wireline (e.g. during heavy jarring). The stuffing box (basically a chamber containing tightly packed glands and pressurized grease) may act under certain combinations of wire velocity and axial load as the tapered tube in the theoretical model outlined above, with the rubber performing the same function as the molten polymer.

9.10 WIRELINE SURFACE EQUIPMENT

Wireline service is a method by which various well maintenance, remedial, control and safety functions are accomplished under pressure in the wellbore. This is done by using a 'tool string' to run and pull the tools and equipment into and out of the wellbore by use of a small diameter wireline from a wireline unit at the surface. To enable the tools to be run into the well under pressure, we require the surface equipment shown below:

1. Quick unions (Otis or Bowen) Connections for the pressure equipment.
2. Wellhead Adapters/Tree Connection.
3. Pump-in Tees (Optional).
4. Wireline Valve (BOP).
5. Lubricators.
6. Injection Sub. (Optional)
7. Stuffing box (alternate sealing wiper box, grease injector head).
8. Wireline Unit.
9. Hay pulley.
10. Martin Decker weight indicator sensor.
11. Measuring Wheel.
12. Wireline clamp.

9.10.1 Quick Unions

The connections used to assemble the lubricator and related equipment are referred to as Quick Unions. They are designed to be quickly and easily connected by hand. The box end receives the pin end, which carries an 'O'-ring seal. The collar has an internal ACME thread to match the external thread on the box end.

This thread makes up quickly by hand and must be kept clean. The 'O'-ring forms the seal to contain the pressure and must be thoroughly inspected for damage and replaced if necessary. A light film of oil or grease on the pin and 'O'-ring helps in the make-up of the union and helps to prevent cutting of the 'O'-ring. A coating of light oil may be used on the threads (not grease). Pipe wrenches, chain tongs or hammers must never be used to loosen the collar of the union. If it cannot be turned by hand, all precautions must be taken to make sure that the well pressure has been completely released.

NOTE: In general, unions that cannot be loosened easily by hand may indicate that pressure may be trapped inside. Ensure that all pressure is released "before" unscrewing the union.

NOTE: Before making up quick unions the 'O'-ring and threads should be checked.

The collar of the union will make up by hand with the pin end after the pin end has fully engaged into, and shouldered against, the box end. When the collar fully makes up, it should be backed off approximately one quarter of a turn to eliminate any possibility of it sticking due to friction when disconnection is required. Rocking the lubricator to ensure it is correctly aligned will assist in loosening the quick union.

Make sure that tigger lines and hoists are properly positioned to lift the lubricator assembly directly over the wellhead. Otis and Bowen manufacture the two most common types of quick union. (Figure 121).

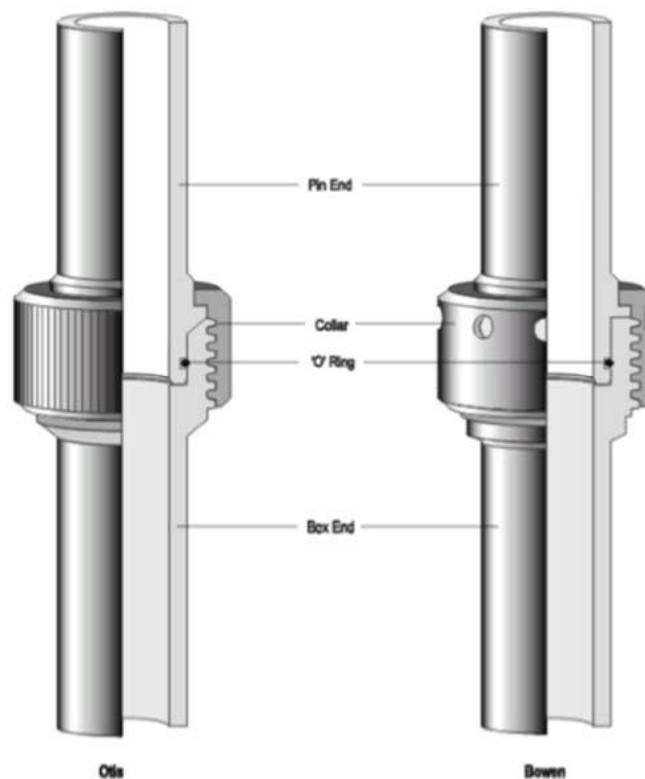
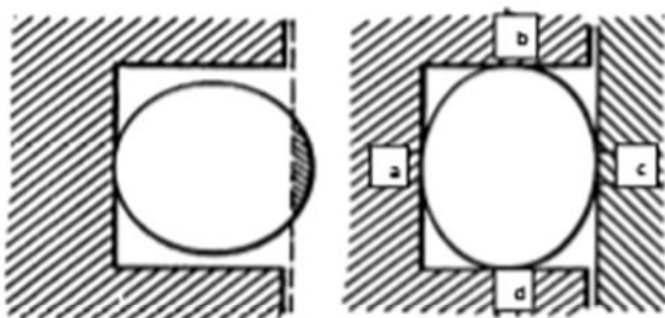

Figure 120 Otis and Bowen Quick unions



A

A correctly sized O-ring in a correspondingly correctly sized groove. The volume of the shaded segment will be displaced when the seal is in its operating position, giving contact areas at a, b, c and d.



B

A larger O-ring in the same size groove would give much greater contact areas at a, b, c, but it would be almost impossible to fit the two components together without damage to the ring.

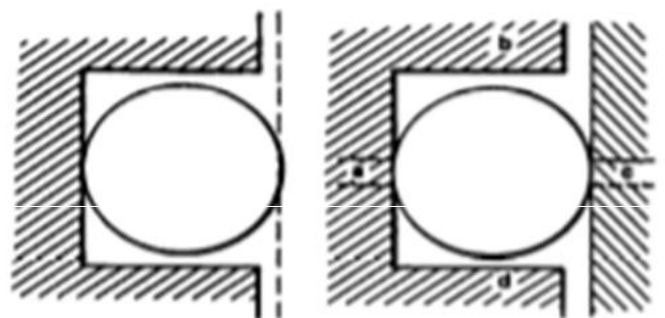

C

Too small an O-ring, or, as in this illustration, too large a diametrical clearance, will give a much smaller volume of ring to be displaced, resulting in poor contact. Contact could be lost altogether at b or d or both.

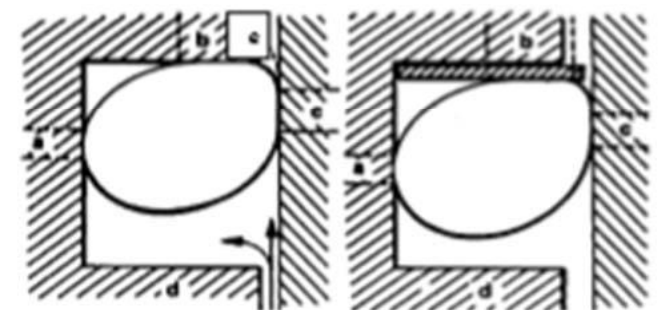

D

In the case of C, should the ring be made of too soft a material, pressure in the case of a static seal, or movement in the case of a dynamic seal, will probably force the ring into a distorted shape, allowing pressure to bleed past C. A sufficiently high pressure may force the ring further (dotted lines), against angle e, where it could sustain circumferential damage. Fitting anti-extrusion or backing rings would prevent this.

Figure 121 O Ring seals

9.10.2 Wellhead Adapter (tree adapter)

All Wellhead Adapters (Figure 123) are crossovers from Xmas tree to the bottom connection of the Wireline Valve or Riser.

It is important to check that the correct type of threads with appropriate pressure ratings are used on the top and bottom of the adapter. In the case of the ACME to Quick Union, it is important that the thread in the top of the Xmas tree is checked for corrosion and/or wear. Three types of Wellhead Adapter; are in common use:

- Quick Union to Quick Union.
- API Flange to Quick Union.
- Acme Thread (or pipe) to Quick Union.

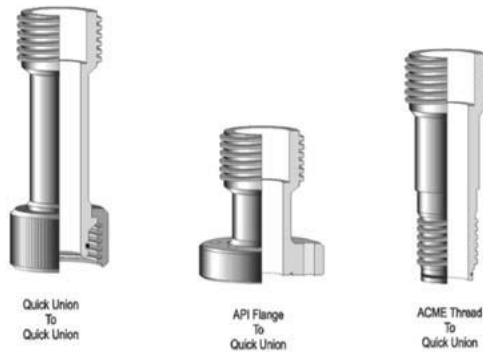

Figure 122 Well head adapter

9.10.3 Pump in tee

A Pump-in Tee; consists of three main parts:

- A Quick Union box end.
- A Quick Union pin end.
- A Chicksan/Weco type connection.

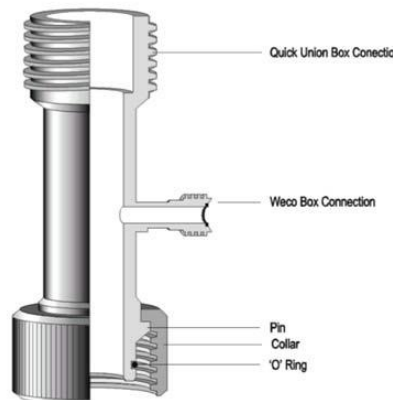

Figure 123 Pump in tree

The Pump-in Tee, can be placed between the Wellhead adapter and the wireline BOP. Therefore, Quick Union sizes and pressure ratings must be compatible with all surface equipment.

Pump-in Tees may be required as part of a wireline rig-up. By connecting a kill-line to the Chicksan/Weco connection, the well can be killed in an emergency situation.

The line can also be used to pressure test or release pressure from the surface equipment.

NOTE: On some locations, the pump-in tee will be part of the wellhead adapter.

9.10.4 Wireline Valve/Blow Out Preventer (BOP)

A wireline valve or blowout preventer (BOP) must always be installed between the wellhead/Xmas tree and wireline lubricator.

The BOP is a piece of safety equipment that can close around the wireline and seal off the well below it. This enables the pressure to be bled off above it, allowing work or repairs to be carried out on equipment above the BOP without pulling the wireline tools to surface. A positive seal is accomplished by means of rams which are manually or hydraulically closed without causing damage to the wire. Hydraulically actuated BOPs are more commonly used because of the speed of closing action and ease of operation. Often during an emergency, the BOP is not easily accessible to allow fast manual operation and therefore remote actuation are preferred. Single or dual ram BOPs are available in various sizes and in a full range of working pressure ratings. Dual rams offer increased safety during slick line work and allow the injection of grease to secure a seal on braided wireline. They are used particularly in gas wells, or wells with a gas cap at surface. BOPs are fitted with equalizing valves that allow lubricator and well pressure to equalize prior to opening the rams when wireline operations are to be resumed. Without this, if the BOP rams were to be opened without first equalizing, the pressure surge can blow the tool or wire into the top of the lubricator, causing damage or breakage. Care must be taken with hydraulic BOPs to ensure that hydraulic pressure is kept to a minimum when opening or closing Rams.

9.10.5 Lubricators

The lubricator is in effect a pressure vessel situated above the Xmas tree, subject to the wellhead shut-in pressure and also test pressures. For this reason, it must be regularly inspected and tested in accordance with statutory regulations. All lubricator sections and accessories subject to pressure are to be banded with stainless steel, with maximum working pressure, test pressure, and date and rating of last hydrostatic test, or uniquely numbered and have a traceable certification file kept where it is easily accessible (Figure 125).

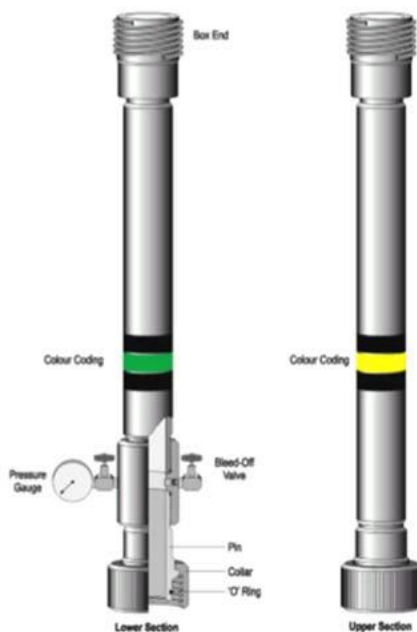

Figure 124 Lubricator

A lubricator allows wireline tools to enter or be removed from the well under pressure. The lubricator is a tube of selected ID and can relate to other sections to the desired length by means of "quick unions".

The following factors govern the selection of lubricators:

- Shut-in wellhead pressure and well fluid.
- Wireline tool diameter.
- Length of wireline tools.
- Type of service (H₂S or sweet gas/oil).

The bottom lubricator section normally has one or more NPT ports installed; a pressure manifold with gauge can be connected to one of the ports to monitor pressure in the lubricator. A second port could be blanked or have a needle valve installed. If the lubricator has no facility to install valves then a "bleed off sub", a short lubricator section with two valves fitted should be connected between the BOP and lubricator. Many lubricators are being manufactured in single piece units where only the quick-unions are changeable. If the NPT thread for the gauge becomes worn, (which can happen very quickly), the lubricator is unserviceable. It is therefore recommended that thread saver subs are used for the mounting of gauge manifolds. The thread savers should not be removed unless necessary
NOTE: The minimum length of the lubricator must be longer than the maximum length of the tool string to be run/pulled.

9.10.6 Injection Sub (Optional)

An injection sub resembles a short lubricator section with quick union connections at either end. The injection sub should be installed immediately below the stuffing box in the surface rig-up. A check valve is installed in the body of the injection sub as part of the injection line. The purpose of the check valve is to contain well pressure in the event of hose failure and must be in working order. The injection sub is used to introduce fluids into the lubricator during wireline operations to counteract one or more of the followings:

- Corrosive environments (e.g. H₂S inhibitors).
- Hydrate formation (glycol injection/methanol injection).
- Dry gas conditions (oil).

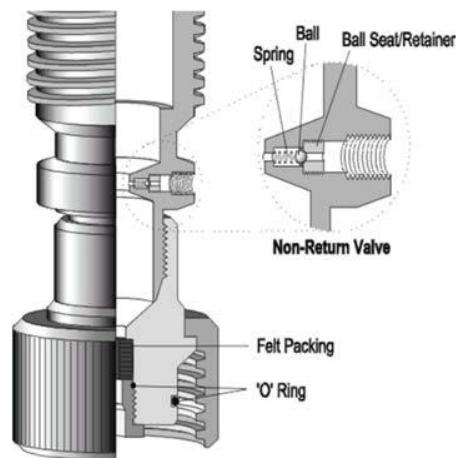

Figure 125 Injection sub

9.10.7 Stuffing box (alternate sealing wiper box, grease injector head)

The stuffing box is a sealing device connected to the top of the lubricator sections (Figure 127). It allows the wireline to enter the well under pressure and provides a seal should the wireline break and be blown

out of the packing. The stuffing box will cater for all sizes of slickline but the size of the wire must be specified to ensure the correct packing rubbers, upper + lower gland, and BOP are installed. If the wireline breaks in the well, the loss of weight on the wire at surface allows well pressure to eject the wire from the well. To prevent well fluids leaking out the hole through the packing stack, an internal blow out preventer plunger is forced up into the stuffing box by well pressure and seals against the lower gland.

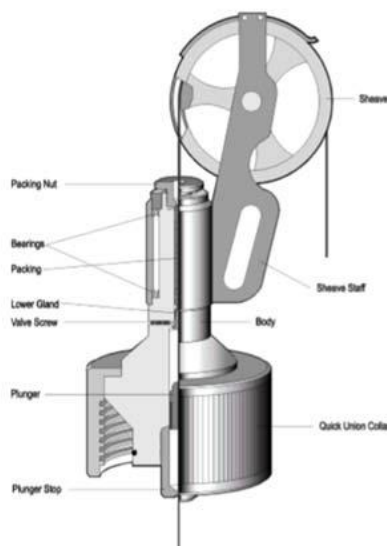

Figure 126 Stuffing box

9.10.8 Wireline Unit

The wireline winch has progressed from a hand-operated reel, driven by a belt and propelled by a pulley attached to the rear axle of a car or pick-up to the present-day truck/skid mounted units. Today's wireline operations are often complex and demanding with wireline work being carried out at ever increasing depths. To meet these demands, the modern wireline unit has been developed to provide increased power and transportability while meeting strict safety requirements. A wireline winch is used as the means of lowering and raising tool strings in wells that require wireline servicing. A winch will consist of these major assemblies:

- Wireline Drum (single or Double).
- Controls.
- Combined Winches / Power Pack.

The drum assembly can be single or double, the double drum offering the facility of running two sizes of wireline from one winch e.g. 0.108" slickline and 3/16 inches braided line, 0.108" and 0.125" or 0.108" slickline and 7/32 inches mono-conductor, for electric line operations etc. A wireline measuring head is installed as part of the unit assembly; head design will be dependent on wire diameter and type. The most common found power units to drive wireline winches are diesel powered hydraulic systems. Electrically powered winches are also used in some areas. (Both of these power packs are discussed later in this Section). Available hydraulic power must be enough to support lengthy jarring operations; the unit must be compact for offshore locations and satisfy zoning regulations for hazardous area use. The power pack and winch may be combined into one unit, or separate components may be utilized which require the connection of hoses to complete the hydraulic circuit. Regardless of winch design, certain basic controls are common to all types of unit. Additional controls and instrumentation are installed to ease winch operation and will be dependent again, on the type of unit used.

Basic controls/instruments are:

- Drum brake - to keep drum stationary or used when jarring.
- Direction lever - to select rotation direction of drum.
- Gear Box - to select speed of drum rotation (usually 4 gears).
- Hydraulic control valve (double A valve) - to control speed of drum rotation.
- Weight indicator - to measure strain on wireline.
- Counter/Odometer - to indicate wireline depth.

Many wireline winches are equipped with a spool-off and cat-head assembly. Hydraulically operated, this provides a facility to spool wire off or onto the wireline drum.



Figure 127 Wireline unit and Power Pack

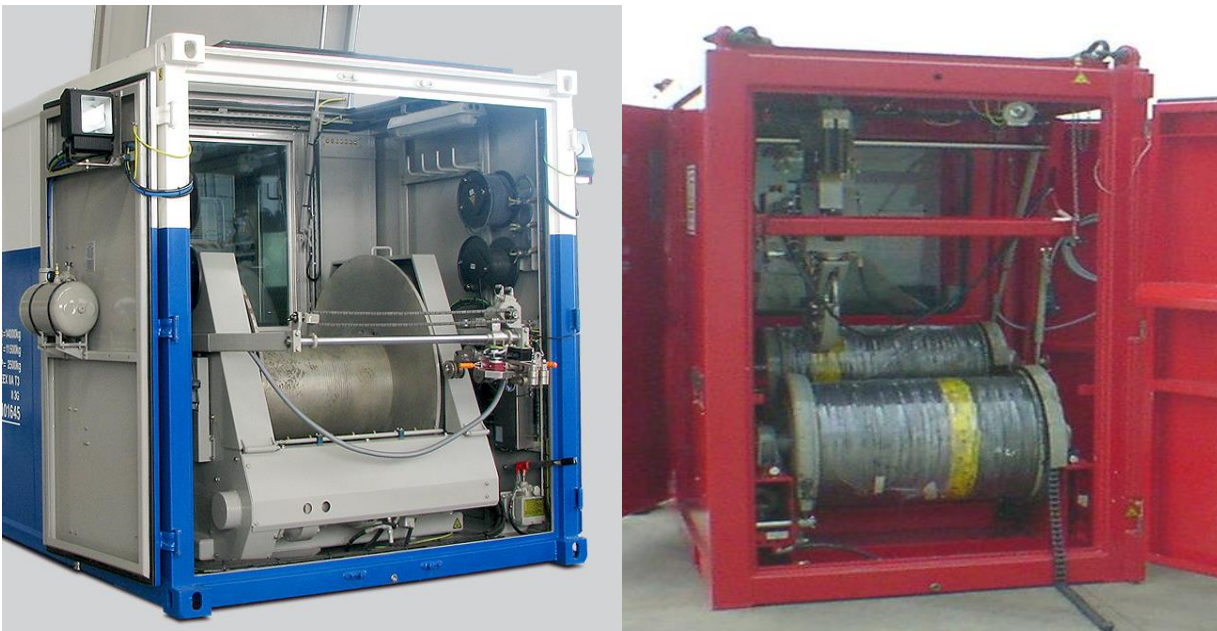

Figure 128 Slickline unit

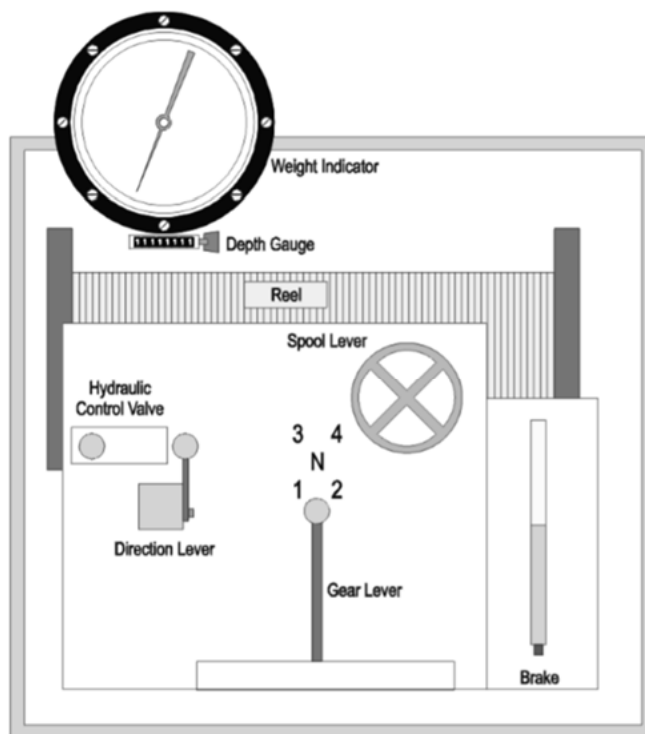

Figure 129 Wireline unit controls

9.10.9 Hay Pulley

There is normally only one hay pulley used, its purpose being to change the direction and level of the wire from vertical at the top of the lubricator to horizontal at the level of the wireline unit. The hay pulley is positioned generally at the wellhead using a pad eye and a certified sling on offshore locations to guide the wireline from the stuffing box to the wireline unit. The hay pulley should be so positioned that the wireline goes through an angle of 90° at the wellhead or lubricator/riser as this is necessary to ensure accurate weight indicator readings when the hay pulley is attached to the wellhead via a weight indicator.

In addition, the location of the hay pulley must be such that wireline handling when jarring up by hand, hand feeling of the wireline tool string into the lubricator or when pulling out of the well, etc. can be readily accomplished. It is also important to secure the hay pulley as close as possible to the wellhead or riser to avoid lateral loading of the lubricator during heavy jarring operations. Securing of the hay pulley to the wellhead must be accomplished by means of a wire sling, never a rope. The hay pulley should be installed with the lock pin facing upwards to ensure that it cannot fall out during wireline operations. Sheaves are manufactured to suit the wireline size. The sheave diameters for well measuring lines should be as large as the design of the equipment will permit but not less than 120 times the diameter of the wire, otherwise cold working of wireline material will occur, resulting in premature failure. The hay pulley generally has a hole for the attachment of a line wiper which is used to remove corrosive liquids and dirt from the line as it is spooled onto the drum.

9.10.10 Martin Decker Weight Indicator Sensor

Weight indicators are instruments which measure the tension placed on the wireline at the surface. There are various types, but all are either hydraulic or electronically operated.

The weight indicators commonly used are:

- The Martin Decker with the tree mounted load cell
- The unit-mounted electronic type as used in advanced wireline unit counter-heads.

9.10.11 Measuring Wheel

The purpose of the measuring wheel is to indicate accurately the length of wire passing through it. It is set to zero with the tool at the wellhead, and therefore measures the depth of the tool in the well.

The main component of the counter is an accurately machined grooved sheave around which the wireline is normally wrapped once. Contact of the wireline with this measuring wheel is maintained by the tension in the wireline and by two adjustable pressure wheels machined to fit into the groove of the measuring wheel.

The wheel is attached, either directly to the axis of a digital meter (odometer) or by means of a flexible drive, permitting location of the meter on the panel inside the cabin of the wireline unit.

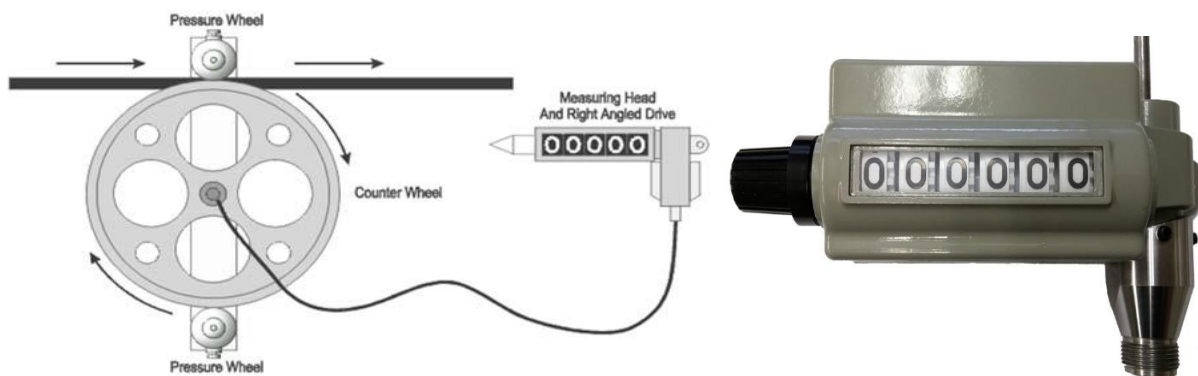

Figure 130 Measuring wheel

9.10.12 Wireline Clamp

The clamp is used to hold the wire while raising or lowering the lubricator and can be utilized during fishing operations.

Clamps must be kept clean and dry to allow maximum grip on the wire.

The clamp is employed when it is necessary to clamp the wire and to hold the tool-string in position, the tension from the unit to be slackened off during rigging up/down or on operations where the tools are to be left in the well.

It is also used in fishing operations to engage a wireline which has parted above the BOP or stuffing box. The clamp has grooves in the clamping jaws which grip the wire without crushing it, assisted by a spring. It is usually attached to the lubricator by a clamp which is bolted around the base of the bottom section of lubricator.

Care must be taken when placing the clamp on the line not to kink the wire. This can result in a weak point or cause the line to stick in the stuffing box.



Figure 131 Wireline clamp

9.11 WIRELINE LOGS AND TOOLS

First developed by Conrad and Marcel Schlumberger in 1927, wireline logs measure formation properties in a well through electrical lines of wire. Different from measurement while drilling (MWD) and mud logs, wireline logs are constant downhole measurements sent through the electrical wireline used to help geologists, drillers and engineers make real-time decisions about drilling operations. Wireline logs can measure resistivity, conductivity and formation pressure, as well as sonic properties and wellbore dimensions. The logging tool, also called a sonde, is located at the bottom of the wireline. The measurements are taken by lowering the wireline to the prescribed depth and then raising it out of the well. The measurements are taken continuously on the way up, to sustain tension on the line. Wireline tools are specially designed instruments lowered into a well bore on the end of the wireline cable. They are individually designed to provide any number of services, such as evaluation of the rock properties, the location of casing collars, formation pressures, information regarding the pore size or fluid identification and sample recovery. Modern wireline tools can be extremely complicated and are often engineered to withstand very harsh conditions such as those found in many modern oil, gas, and geothermal wells. Pressures in gas wells can exceed 30,000 psi, while temperatures can exceed 500 deg Fahrenheit in some geothermal wells. Corrosive or carcinogenic gases such as hydrogen sulfide can also occur downhole. To reduce the amount of time running in the well, several wireline tools are often joined together and run simultaneously in a tool string that can be hundreds of feet long and weigh more than 5000 lbs.

9.11.1 Natural Gamma Ray Tools

Natural gamma ray tools are designed to measure gamma radiation in the Earth caused by the disintegration of naturally occurring potassium, uranium, and thorium. Unlike nuclear tools, these natural gamma ray tools emit no radiation. The tools have a radiation sensor, which is usually a scintillation crystal that emits a light pulse proportional to the strength of the gamma ray striking it. This light pulse is then converted to a current pulse by means of a photomultiplier tube (PMT). From the photomultiplier tube, the current pulse goes to the tool's electronics for further processing and ultimately to the surface system for recording. The strength of the received gamma rays is dependent on the source emitting gamma rays, the density of the formation, and the distance between the source and the tool detector. The log recorded by this tool is used to identify lithology, estimate shale content, and depth correlation of future logs.

9.11.2 Nuclear Tools

Nuclear tools measure formation properties through the interaction of reservoir molecules with radiation emitted from the logging tool. The two most common properties measured by nuclear tools are formation porosity and rock density:

Formation porosity is determined by installing a radiation source capable of emitting fast neutrons into the downhole environment. Any pore spaces in the rock are filled with fluid containing hydrogen atoms, which slow the neutrons down to an epithermal or thermal state. This atomic interaction creates gamma rays which are then measured in the tool through dedicated detectors and interpreted through a calibration to a porosity. A higher number of gamma rays collected at the tool sensor would indicate a larger number of interactions with hydrogen atoms, and thus a larger porosity.

Density tools use gamma ray radiation to determine the lithology and density of the rock in the downhole environment. Modern density tools utilize a Cs-137 radioactive source to generate gamma rays which interact with the rock strata. Since higher density materials absorb gamma rays much better than lower density materials, a gamma ray detector in the wire line tool can accurately determine formation density by measuring the number and associated energy level of returning gamma rays that have interacted with the rock matrix. Density tools usually incorporate an extendable caliper arm, which is used both to press the radioactive source and detectors against the side of the bore and to measure the exact width of the bore to remove the effect of varying bore diameter on the readings. Some modern nuclear tools use an electronically powered source controlled from the surface to generate neutrons. By emitting neutrons of varying energies, the logging engineer can determine formation lithology in fractional percentages.

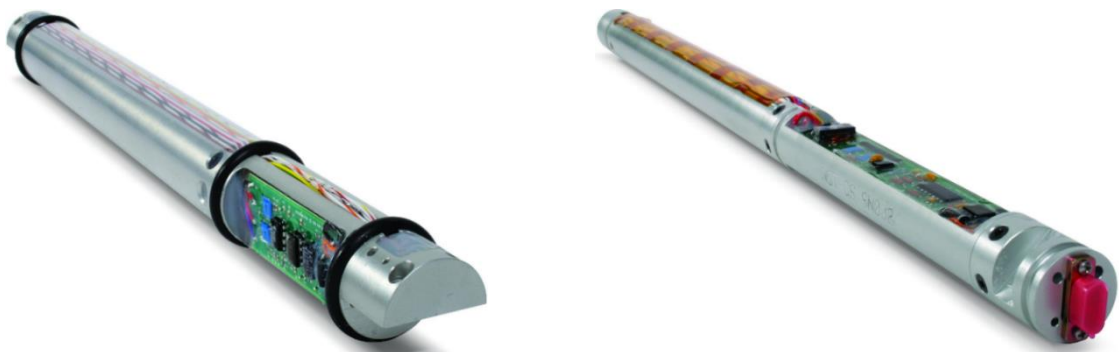

Figure 132 Gamma and Electronic tools

9.11.3 Resistivity Tools

In any matrix which has some porosity, the pore spaces will be filled with a fluid of oil, gas (either hydrocarbon or otherwise) or formation water (sometimes referred to as connate water). This fluid will saturate the rock and change its electrical properties. A wireline resistivity tool direct injects current (laterolog-type tools for conductive water-based muds) or induces (induction-type tools for resistive or oil-based muds) an electric current into the surrounding rock and determines the resistivity via Ohm's law. The resistivity of the formation is used primarily to identify pay zones containing highly resistive hydrocarbons as opposed to those containing water, which is generally more conductive.

It is also useful for determining the location of the oil-water contact in a reservoir. Most wireline tools can measure the resistivity at several depths of investigation into the bore hole wall, allowing log analysts to accurately predict the level of fluid invasion from the drilling mud, and thus determine a qualitative measurement of permeability.

Some resistivity tools have many electrodes mounted on several articulated pads, allowing for multiple micro-resistivity measurements. These micro-resistivities have a very shallow depth of investigation, typically in the range of 0.1 to 0.8 inches, making them suitable for borehole imaging. Resistivity imagers are available which operate using induction methods for resistive mud systems (oil base), and direct current methods for conductive mud systems (water based).

9.11.4 Sonic and Ultrasonic Tools

Sonic tools, such as the Baker Hughes XMAC-F1, consist of multiple piezoelectric transducers and receivers mounted on the tool body at fixed distances. The transmitters generate a pattern of sound waves at varying operating frequencies into the down hole formation. The signal path leaves the transmitter passes through the mud column, travels along the borehole wall and is collected at multiple receivers spaced out along the tool body. The time it takes for the sound wave to travel through the rock is dependent on several properties of the existing rock, including formation porosity, lithology, permeability and rock strength. Different types of pressure waves can be generated in specific axis, allowing geoscientists to determine anisotropic stress regimes. This is very important in determining hole stability and aids drilling engineers in planning for future well design.

Sonic tools are also used extensively to evaluate the cement bond between casing and formation in a completed well, primarily by calculating the accentuation of the signal after it as passed through the casing wall (see Cement Bond Tools below).

Ultrasonic tools use a rotating acoustic transducer to map a 360-degree image of the borehole as the logging tool is pulled to surface. This is especially useful for determining small scale bedding and formation dip, as well as identifying drilling artifacts such as spiraling or induced fractures.

9.11.5 Nuclear Magnetic Resonance Tools

A measurement of the nuclear magnetic resonance (NMR) properties of hydrogen in the formation. There are two phases to the measurement: polarization and acquisition. First, the hydrogen atoms are aligned in the direction of a static magnetic field (B_0). This polarization takes a characteristic time T_1 . Second, the hydrogen atoms are tipped by a short burst from an oscillating magnetic field that is designed so that they process in resonance in a plane perpendicular to B_0 . The frequency of oscillation is the Larmor frequency. The precession of the hydrogen atoms induces a signal in the antenna. The decay of this signal with time is caused by transverse relaxation and is measured by the CPMG pulse sequence. The decay is the sum of different decay times, called T_2 . The T_2 distribution is the basic output of a NMR measurement.

The NMR measurement made by both a laboratory instrument and a logging tool follow the same

principles very closely. An important feature of the NMR measurement is the time needed to acquire it. In the laboratory, time presents no difficulty. In a log, there is a trade-off between the time needed for polarization and acquisition, logging speed and frequency of sampling. The longer the polarization and acquisition, the more complete the measurement. However, the longer times require either lower logging speed or less frequent sampling.

9.11.6 Cement Bond Tools

A cement bond tool, or CBT, is an acoustic tool used to measure the quality of the cement behind the casing. Using a CBT, the bond between the casing and cement as well as the bond between cement and formation can be determined. Using CBT data, a company can troubleshoot problems with the cement sheath if necessary. This tool must be centralized in the well to function properly.

Two of the largest problems found in cement by CBT's are channeling and micro-annulus. A micro annulus is the formation of microscopic cracks in the cement sheath. Channeling is where large, contiguous voids in the cement sheath form, typically caused by poor centralization of the casing. Both situations can, if necessary, be fixed by remedial electric line work.

A CBT makes its measurements by rapidly pulsing out compressional waves across the well bore and into the pipe, cement, and formation. The compressional pulse originates in a transmitter at the top of the tool, which, when powered up on surface sounds like a rapid clicking sound. The tool typically has two receivers, one three feet away from the receiver, and another at five feet from the transmitter. These receivers record the arrival time of the compressional waves. The information from these receivers are logged as travel times for the three- and five-foot receivers and as a micro-seismogram. Recent advances in logging technologies have allowed the receivers to measure 360 degrees of cement integrity and can be represented on a log as a radial cement map and as 6-8 individual sector arrival times.

9.11.7 Casing Collar Locators

Casing collar locator tools, or CCL's, are among the simplest and most essential in cased hole electric line. CCL's are typically used for depth correlation and can be an indicator of line overspeed when logging in heavy fluids.

9.11.8 CCL Log

A CCL operates on Faraday's Law of Induction. Two magnets are separated by a coil of copper wire. As the CCL passes by a casing joint, or collar, the difference in metal thickness across the two magnets induces a current spike in the coil. This current spike is sent up hole and logged as what's called a collar kick on the cased hole log.

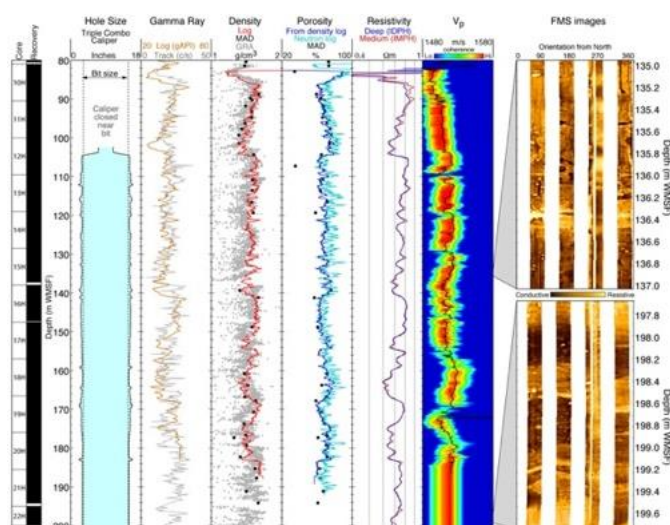

Figure 133 Casing Collar Log

9.11.9 Gamma Perforating Tools

A cased hole gamma perforator is used to perform mechanical services, such as shooting perforations, setting downhole tubing/casing elements, dumping remedial cement, tracer surveys, etc. Typically, a gamma perforator will have some sort of explosively initiated device attached to it, such as a perforating gun, a setting tool, or a dump bailer. In certain instances, the gamma perforator is used to merely spot objects in the well, as in tubing conveyed perforating operations and tracer surveys.

Gamma perforators operate in much the same way as an open hole natural gamma ray tool. Gamma rays given off from naturally occurring radioactive elements bombard the scintillation detector mounted on the tool. The tool processes the gamma ray counts and sends the data up hole where it is processed by a computerized acquisition system and plotted on a log versus depth. The information is then used to ensure that the depth shown on the log is correct. After that, power can be applied through the tool to set off explosive charges for things like perforating, setting plugs or packers, dumping cement, etc.

9.11.10 Wireline Pressure Setting Assemblies (WLSPA)

Setting tools are used to set downhole completion elements such as production packers or bridge plugs. Setting tools typically use the expanding gas energy from a slow burning explosive charge to drive a hydraulic piston assembly. The assembly is attached to the plug or packer by means of a setting mandrel and a sliding sleeve, which when "stroked" by the piston assembly, effectively squeezes the elastomer elements of the packing element, deforming it sufficiently to wedge it into place in the tubing or casing string. Most completion packers or plugs have a specially designed shear mechanism which release the setting tool from the element allowing it to be retrieved back to surface. The packer/plug however, remains down hole as a barrier to isolate production zones or permanently plug off a well bore.

9.11.11 Cable Head

The cable head is the upper most portion of the tool string on any given type of wireline. The cable head is where the conductor wire is made into an electrical connection that can be connected to the rest of the tool string. Cable heads are typically custom built by the wireline operator for every job and depend greatly on depth, pressure and the type of wellbore fluid.

Electric line weak points are also located in the cable head. If the tool is to become stuck in the well, the weak point is where the tool would first separate from the wireline. If the wireline were severed anywhere else along the line, the tool becomes much more difficult to fish.

9.11.12 Tractors

Tractors are electrical tools used to push the tool string into hole, overcoming wireline's disadvantage of being gravity dependent. These are used for in highly deviated and horizontal wells where gravity is insufficient, even with roller stem. They push against the side of the wellbore either using wheels or through a wormlike motion.

9.11.13 Measuring Head

A measuring head is the first piece of equipment the wireline comes into contact with off the drum. The measuring head is composed of several wheels which support the wireline on its way to the winch and they also measure crucial wireline data.

A measuring head records tension, depth, and speed. Current models use optical encoders to derive the revolutions of a wheel with a known circumference, which in turn is used to figure speed and depth. A wheel with a pressure sensor is used to figure tension.

9.12 PERFORATION

Perforating is the process through which communication is established between the reservoir and the wellbore.

It sounds so simple that is difficult to understand how it can be such a source of controversy in our industry.

Decades of misapplication and unsupported “rules of thumb” have made it difficult to sort out the important factors. By investigating the basics, it is possible to gain an appreciation for the vital elements.

9.12.1 Perforated vs. Open hole

While it is widely known that open hole completions generally allow the highest production rates, the clear majority of wells producing hydrocarbons do so through perforated casing. The two most common reasons given for such completions are formation support and zone selectivity.

Without the support of the casing and its associated cement sheath, completions may become restricted or bridge off. Production of large quantities of formation solids can cause serious problems with production equipment as well as subsidence near the wellbore.

Zone selectivity is extremely desirable in a completion to prevent unwanted production of water or gas, for accurate placement of injection fluids in flood and pressure maintenance projects, and for proper application of costly stimulation techniques.

9.12.2 Bullets, Jets, or Hydraulic

Three general methods are available for establishing a selective cased hole completion: bullet perforating, jet perforating, and hydraulic-abrasive jetting.

To appreciate the popularity of jets compared to the earlier methods, one only needs to look at the limitations of each. While bullet perforators are known to produce very uniform diameter holes, their depth of penetration falls off dramatically as compressive strength of rock increases. Figure 134 indicates this fact. Where bullet perforators are still offered commercially today are in those areas where cost and uniform hole size outweigh depth of penetration. Figure 135 also indicates the relative “performances” of shaped-charge jet perforating and hydraulic abrasive perforating. It is easy to see that the hydraulic perforator suffers less performance decline as rock strength increases, but its failure to perforate to any significant depth in a reasonable amount of time make it a costly alternative.

Figure 135 shows how a shaped charge with liner produces a much more concentrated explosive “jet” than other configurations. During the four decades that jet perforating has been popular, the refinement of both the design and materials has led to extremely efficient devices. Intense competition in the marketplace has produced several important breakthroughs.

The charges themselves are all remarkably similar. Shaped charges are all composed of four main components. The explosive or main charge is enclosed in some type of case. It may be made of aluminum, ceramic, glass, rubber, steel, or a combination of these.

The purpose of the case is to physically confine the explosive so that the charge can be loaded physically into a carrier or “gun” that is used to carry the shaped charges into the well for proper placement for firing.

The case also provides a means for attaching detonation cord to the charge as well as controlling charge to target spacing.

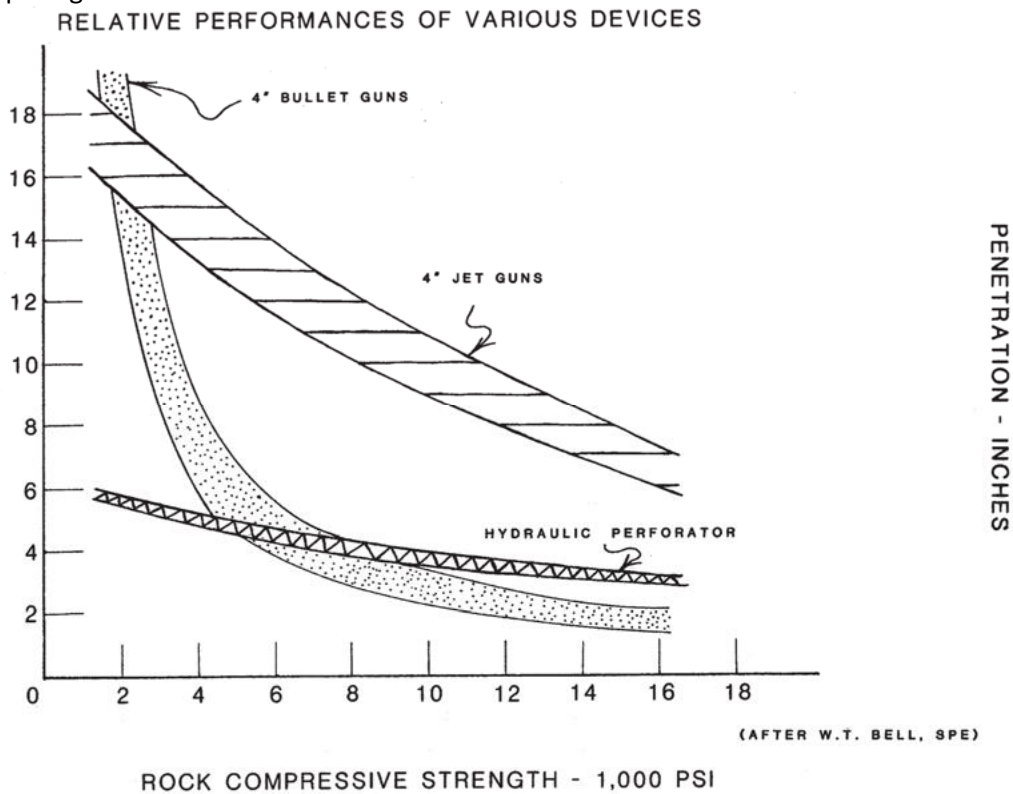

Figure 134 relative “performances” of shaped-charge jet and hydraulic abrasive perforating

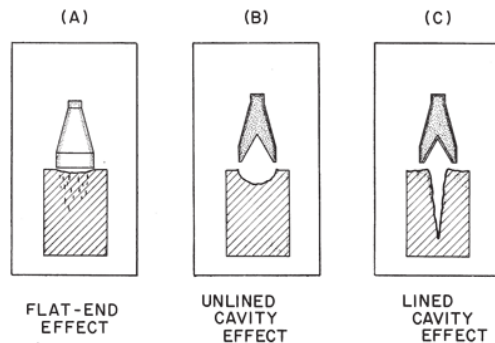

Figure 135 Shaped Charge



10 COILED TUBING

10.1 OBJECTIVES

After studying this section, the trainees should be able to perform the following:

- Describe the function of coiled tubing (CT) operation in drilling and workover.
- Describe the function of all components of the Rig Up Equipment.
- Describe the preventive maintenance.
- Describe the operational procedures.
- Describe the rig up/rig down procedures related to CT.
- Describe CT operator's general safety precautions and emergency response procedures.

10.2 OUTCOMES

Upon completing their training, the participants should be able to:

- Execute written and verbal instructions and effectively exchange information with peers and superiors.
- Perform basic mathematical calculations and basic reading comprehension and writing skills.
- Proficient in product line service equipment and procedures.
- Demonstrate knowledge of all CT services and related products.
- Assemble and prepare equipment for installation and service.
- Maintain general housekeeping and perform pre/post job coiled tubing equipment inspections.
- Assist in CT unit operation (engine, drive train, and hydraulics), minor unit maintenance, and Process documentation.
- Comply with all HSE regulations.

10.3 OVERVIEW

In the oil and gas industries, coiled tubing refers to a very long metal pipe, normally 1 to 3.25 in (25 to 83 mm) in diameter which is supplied spooled on a large reel. It is used for interventions in oil and gas wells and sometimes as production tubing in depleted gas wells. Coil tubing has also been used as a cheaper version of work-over operations. Coiled tubing is often used to carry out operations like wire lining. The main benefits over wireline are the ability to pump chemicals through the coil and the ability to push it into the hole rather than relying on gravity.

The tool string at the bottom of the coil is often called the bottom hole assembly (BHA). It can range from something as simple as a jetting nozzle, for jobs involving pumping chemicals or cement through the coil, to a larger string of logging tools, depending on the operations.

Coil tubing can perform almost any operation for oil well operations if used correctly.

10.4 APPLICATIONS

10.4.1 Circulation

The most typical use for CT is circulation. By running coiled tubing into the bottom of the hole and pumping in the gas, the kill fluid can be forced out to production. Circulating can also be used to clean out light debris, which may have accumulated in the hole.

10.4.2 Pumping

In many cases, the use of coiled tubing to deploy a complex pump can greatly reduce the cost of deployment by eliminating the number of units on site during the deploy.

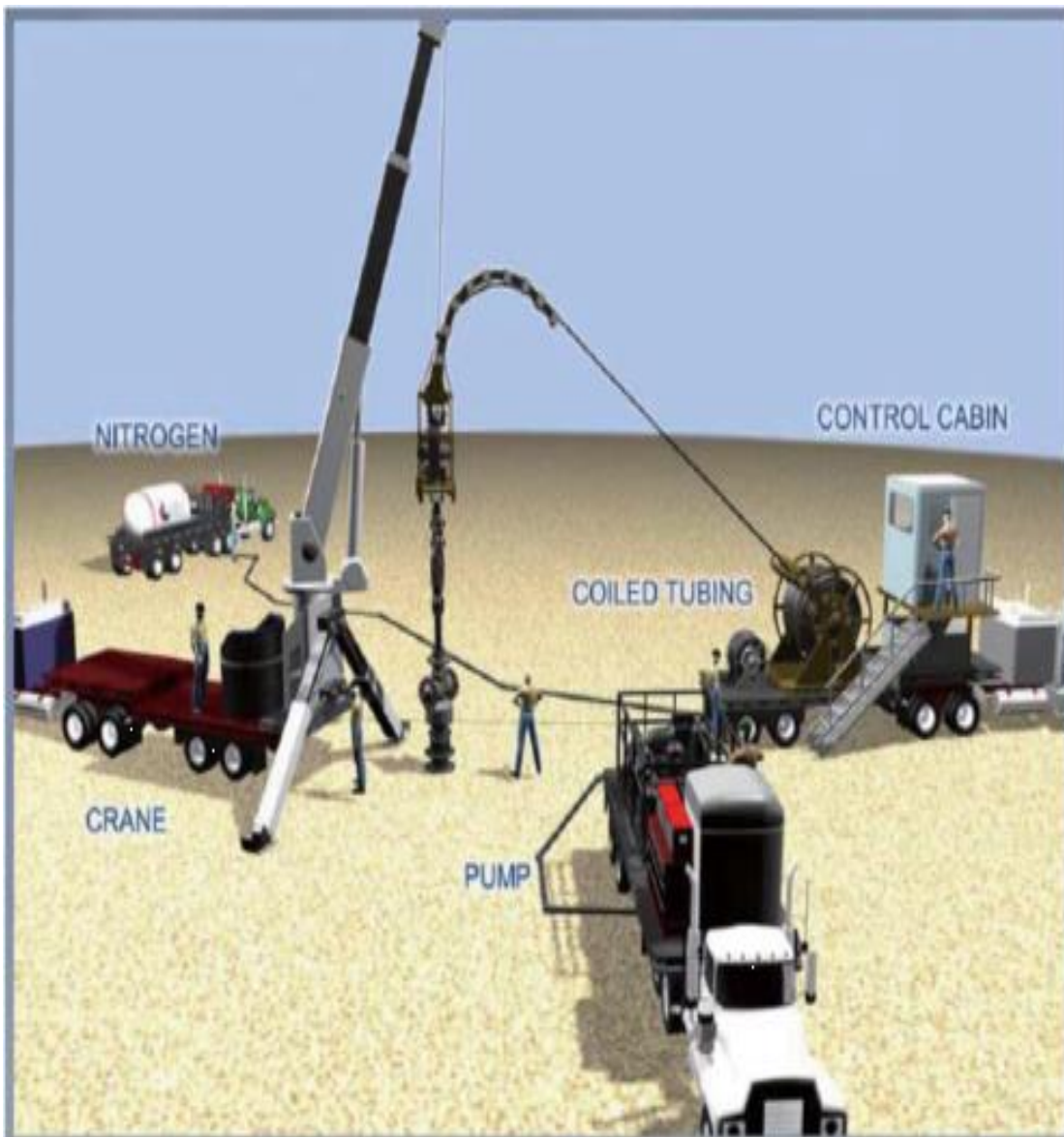

Figure 136 Coiled tubing pumping

10.4.3 Coiled Tubing Drilling (CTD)

A relatively modern drilling technique involves using coiled tubing instead of conventional drill pipe. This has the advantage of requiring less effort to trip in and out of the well (the coil can simply be run in and pulled out while drill pipe must be assembled and dismantled joint by joint while tripping in and out).



Figure 137 Coiled tubing drilling (CTD)

10.4.4 Logging and Perforating

These tasks are by default the area of wire line. Because CT is rigid, it can be pushed into the well from the surface. This is an advantage over wire line.

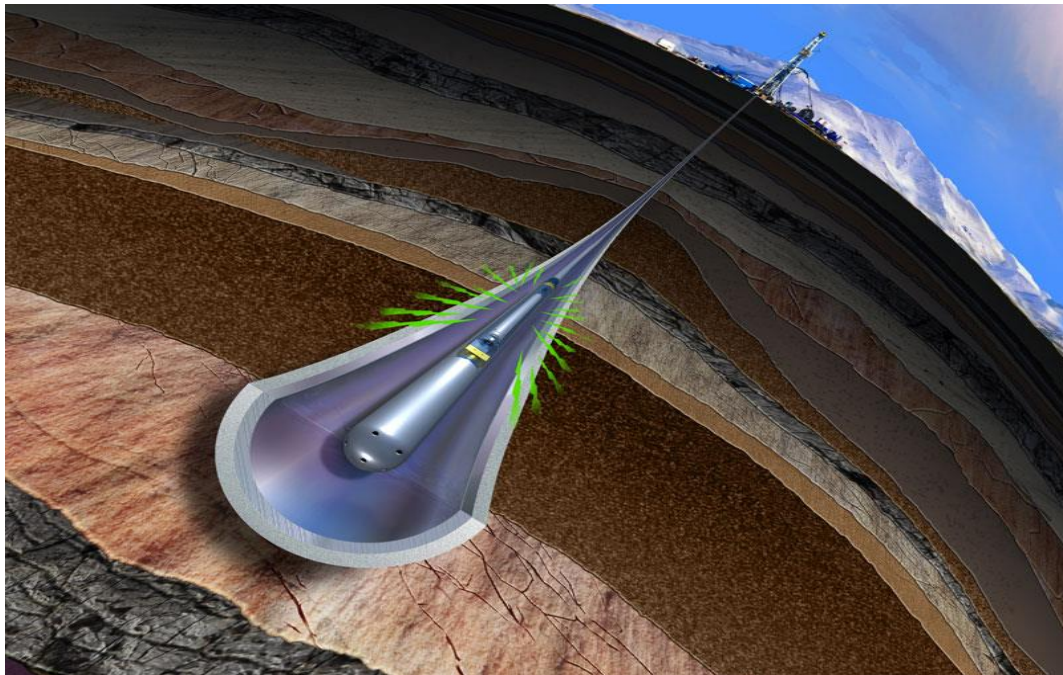

Figure 138 Coiled tubing perforation

10.4.5 Production

CT is often used as a production string in shallow gas wells that produce some water. The narrow internal diameter results in a much higher velocity than would occur inside conventional tubing or inside the casing. This higher velocity assists in lifting liquids to surface.



Figure 139 Coiled tubing production

10.5 MAIN PARTS OF A CT SYSTEM

The basic components of a coiled tubing unit are as follows:

- 1) Tubing Injector Assembly.
- 2) Tubing Guide Arch.
- 3) Service Reel.
- 4) Power Supply / Prime Mover.
- 5) Control Console and Monitoring Equipment.
- 6) Well Control Equipment.



Figure 140 Coiled tubing unit

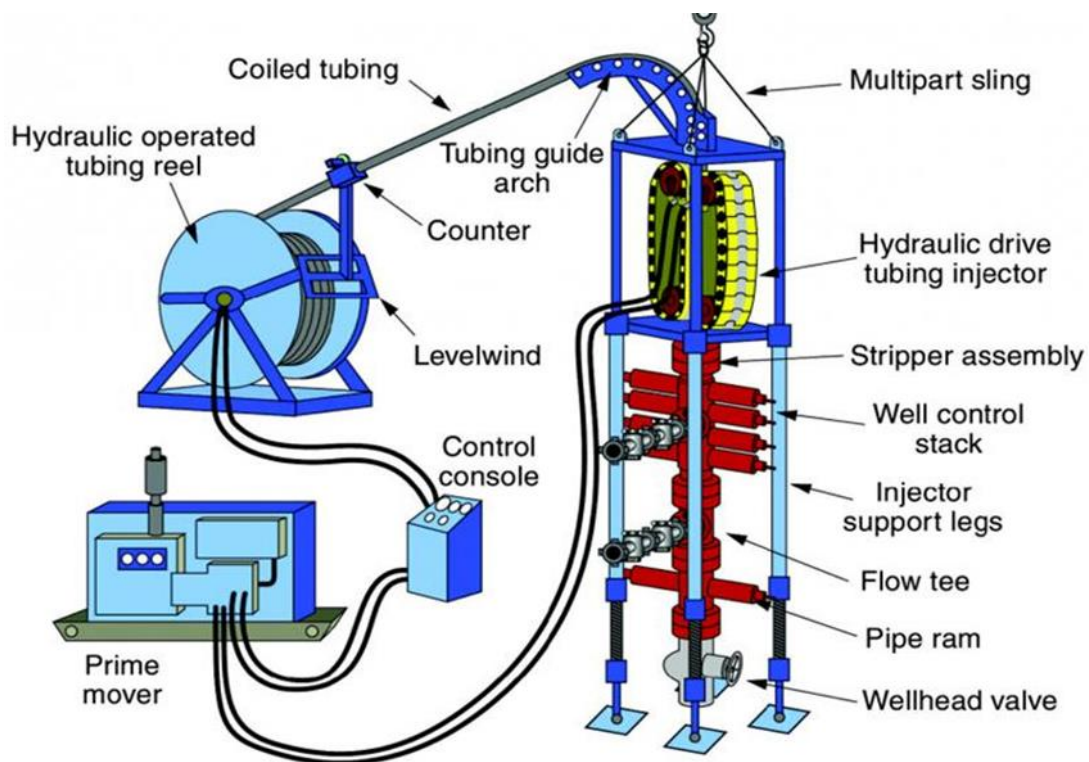

Figure 141 Coiled tubing components

10.5.1 Tubing Injector Assembly

The injector assembly is designed to perform three basic functions:

- Provide the thrust required to snub the tubing into the well against surface pressure and/or to overcome wellbore friction forces.
- Control the rate of lowering the tubing into the well under various well conditions.
- Support the full weight of the tubing and accelerate it to operating speed when extracting it from the well

10.5.1.1 Injector Head – Principal Components

Primary components/functions include:

- Hydraulic drive/brake system (1)
- Drive chains and tensioners (2)
- Gooseneck or guide-arch (3)
- Weight indicator sensor (4)
- Depth system sensor (5)
- Stripper mount (6)

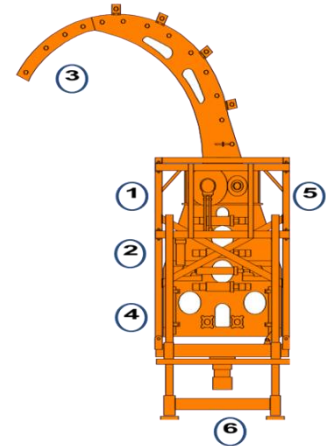

Figure 142 Injector head

10.5.2 Tubing Guide Arch

The tubing arch supports the tubing through the 90 °bending radius and guides the C.T. from the reel into the injector chains.

- Guides tubing into injector.
- Large radius for best tubing life.
- Designed for all typical job set-ups and conditions

API Recommendations	
Tubing Size (in.)	Radius (in.)
1-1/4	48 to 72
1-1/2	48 to 72
1-3/4	72 to 96
2	72 to 96
2-3/8	90 to 120
2-7/8	90 to 120
3-1/2	96 to 120

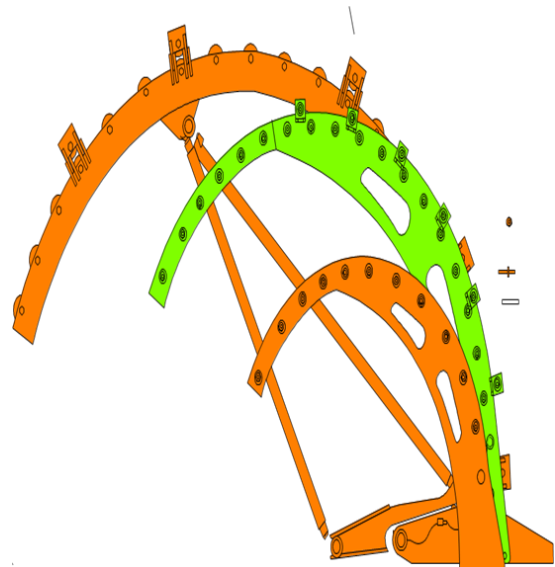

Figure 143 Tubing guide arch

10.5.3 Service Reel

The services reel serves as the C.T. storage mechanism during transport and as the spooling device during C.T. operations.

The rotation of the service reel is controlled by a hydraulic motor.

During R.I.H. slight back pressure is kept on the reel to allow the injector to pull the tubing off of the reel (reel back-tension).

During POOH. This pressure is increased to allow the reel rotation to keep up with the extraction rate of the tubing injector.

Basic functions of the reel or equipment normally mounted on the reel include:

- Storing and protecting the CT string (drum).
- Maintaining proper tension between reel and injector head (reel drive system).
- Efficiently spooling the CT string on to the reel drum (level wind system).
- Circulating fluids with the drum rotating (swivel).
- Application of protective coating or inhibitor on tubing string (tubing lubricator system).
- CT depth measurement system (reel mounted counter).

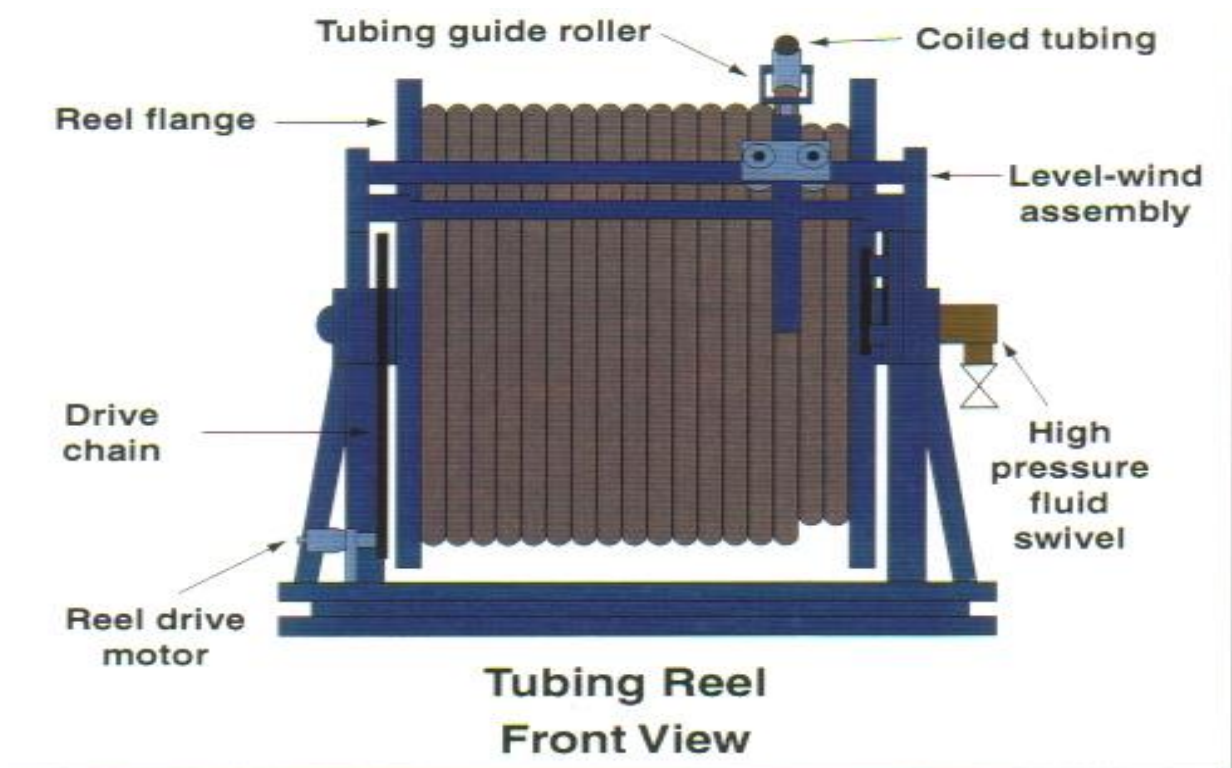

Figure 144 Service reel

10.5.3.1 CT Reel – Primary Components

- Typical reel components:
 - Reel drum (1)
 - Reel drive system (2)
 - Level wind assembly (3)
 - Reel swivel and manifold
 - Lubrication system (4)
 - Depth counter (5)

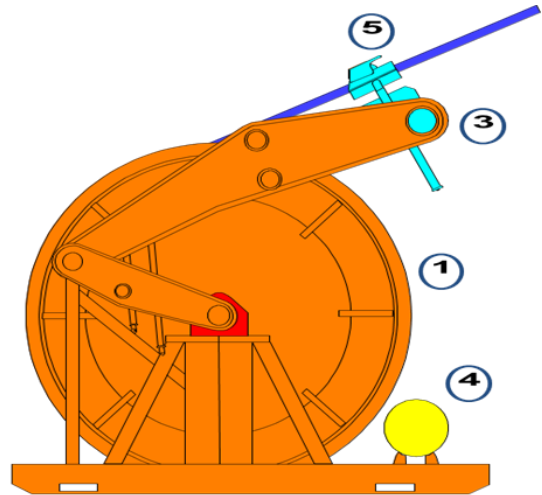

Figure 145 CT Reel side view

10.5.4 Power Supply / Prime Mover

In general, the prime mover packages are equipped with diesel engines and multi-stage hydraulic pumps which are typically rated for pressures of 3,000 psig to 5,000 psig. And in addition, the accumulator package for well control equipment.

The basic functions of the CTU power pack and control cabin are:

- Providing hydraulic power required by the CTU (engine and hydraulic pumps).
- Control and limitation on hydraulic systems (hydraulic control and relief valves/system).
- Hydraulic accumulator storage for secondary well control equipment (BOP accumulator).
- Enables control and monitoring of all operating systems from a single operator's station (control console).
- Providing operations data to enable wellsite design and monitoring.

10.5.4.1 Power Pack – Primary Components

- Power Pack.
 - Engine.
 - Hydraulic pumps.
 - Hydraulic control systems.
 - Onboard accumulators.
- Control cabin
 - System (CTU) instruments and controls.
 - Well/operation monitoring and recording equipment.

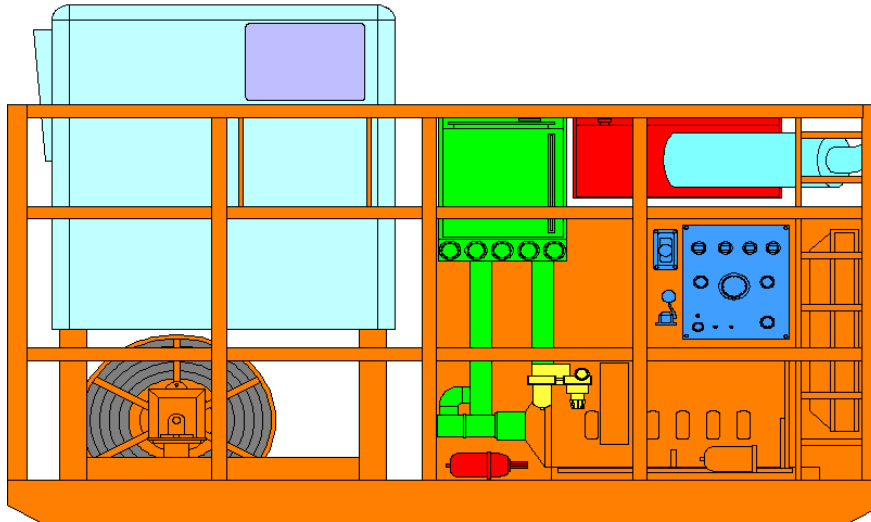

Figure 146 Power supply / prime mover

10.5.5 Control Console & Monitoring System.

The instruments and control systems of any CTU can be categorized as follows: -

- Primary instruments and controls.
 - Weight indicator, circulating and wellhead pressures.
- Secondary instruments and controls.
 - Depth/speed indicator, chain tensioner pressures, stripper system pressure.
- Support instruments and controls.
 - drive system pressures, BOP system pressure, and additional systems.



Figure 147 Control cabin

10.5.6 Well Control Equipment

The well control stack is composed of the stripper assembly and a minimum of four hydraulically

- Operated rams. The four ram components are equipped (from top down) with:
 - **Blind Rams:** Are used to seal the wellbore off at the surface when well control is lost.
 - **Shear Rams:** Are used to mechanically break the C.T. In the event the pipe gets stuck.
 - **Slip Rams:** Are used to support the weight of the pipe below
 - **Pipe Rams:** Are used to isolate the wellbore annulus pressure below.

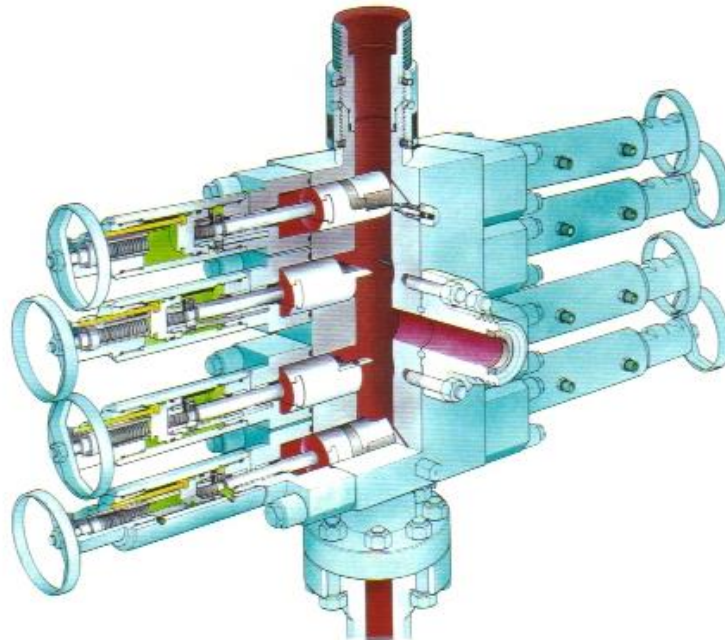

Figure 148 Well control equipment

Pressure control equipment associated with mobilization of a basic CTU for routine service activities includes:

- Stripper.
 - Generally, permanently mounted on the injector head.
- Blow-out preventers.
 - Quad configuration most common.
- Riser, lubricator.
 - Application dependent.
- Auxiliary equipment.
 - Wellhead crossover(s), flow "T", kill line and valves.
- Down hole check valve.
 - Preventing back-flow of wellbore fluids.

10.6 RIG UP

The main engine of a CT intervention is the injector head. This component contains the mechanism to push and pull the coil in and out of the hole. An injector head has a curved guide beam on top called a gooseneck which threads the coil into the injector body. Below the injector is the stripper, which contains rubber pack off elements providing a seal around the tubing to isolate the well's pressure.



Figure 149 General coiled tubing rig up

Below the stripper is the preventer, which provides the ability to cut the coiled tubing pipe and seal the well bore (shear-blind) and hold and seal around the pipe (pipe-slip). Older quad-BOPs have a different ram for each of these functions (blind, shear, pipe, slip).

Newer dual-BOPs combine some of these functions together to need just two distinct rams (shear-blind, pipe-slip).

The BOP sits below the riser, which provides the pressurized tunnel down to the top of the Christmas tree. Between the Christmas tree and the riser is the final pressure barrier, the shear-seal BOP, which can cut and seal the pipe.

10.7 TASKS

Pre-Job Planning

- Well Information
- Pre-Job Calculations
- Equipment Selection
- Application Considerations
- JSA

Pre-Job Procedure

- Job Site Layout
- On-Site Calculations
- Procedure Review
- Questions from the Customer
- On-Site Safety Considerations

Rig-Up

- Unit Components
- Rig-Up Safety Considerations
- Wellhead Control Devices
- Running The Job



11 WELL STIMULATION BY ACIDIZING

11.1 OBJECTIVES

After studying this section, the trainees should be able to perform the following:

- Describe the function of stimulation operation in drilling and workover.
- Describe the function of all components of the Rig Up Equipment.
- Describe the operational procedures.
- Describe the rig up/rig down procedures related to stimulation.
- Describe stimulation operator's general safety precautions and emergency response procedures.

11.2 OUTCOMES

Upon completing their training, the participants should be able to:

- execute written and verbal instructions and effectively exchange information with peers and superiors.
- perform basic mathematical calculations and basic reading comprehension and writing skills.
- demonstrate proficient knowledge of the well stimulation and related products.

11.3 OVERVIEW

Acidizing is the most common form of chemical treatment in use to stimulate a well's ability to produce or accept fluid. The most common type of acidizing is Matrix Acidizing.

Matrix acidizing is injecting the acid into the formation matrix below frac pressure to achieve radial penetration into the formation porosity (intergranular, vugular or fracture porosity).



Figure 150 Matrix Stimulation

11.4 ACID REQUIREMENTS

The ultimate requirement of an acid treatment is to either create or enlarge flow paths downhole. If this is to be accomplished the acid must:

- React with the Objective Material and Yield Soluble Products.
- Be corrosion Inhibited against Reaction with Steel.
- Be Safe to Handle.

Be Low Cost, Readily Available and of Good Quality.

11.5 USES OF ACID

Dissolving Limestone and Dolomite Formation is the major use of hydrochloric acid in oil and gas wells. The purpose of acidizing can be listed below:

- Establish connection to the reservoir.
- Remove damage.
- By-pass damage.
- increase well productivity.
- Increase production rate.
- Decrease injection pressures (injection wells).

Stimulation is achieved by removing the effect of reduced permeability (damage) near the wellbore by enlarging pore spaces and dissolving particles which may be plugging pore spaces.



Figure 151 Acid reaction enlarges pore spaces

12 WELL STIMULATION BY FRACTURING

12.1 OBJECTIVES

After studying this section, the trainees should be able to perform the following:

- Describe the function of stimulation operation in drilling and workover.
- Describe the function of all components of the Rig Up Equipment.
- Describe the operational procedures.
- Describe the rig up/rig down procedures related to stimulation.
- Describe stimulation operator's general safety precautions and emergency response procedures.

12.2 OUTCOMES

Upon completing their training, the participants should be able to:

- execute written and verbal instructions and effectively exchange information with peers and superiors.
- perform basic mathematical calculations and basic reading comprehension and writing skills.
- demonstrate knowledge of all stimulation services and related products.

12.3 OVERVIEW

Fracturing is the stimulation process whereby a crack is made in the earth that connects with the wellbore, thereby providing a greater exposed drainage area of rock that will bleed oil or gas into the wellbore. The crack is created with hydraulic pressure. It extends because fluid is pumped into the crack faster than it can leak off at the walls. It stays open because sand or another proppant is injected into the crack to hold it open.

Physical principles as well as experience dictate that the crack is vertical in all wells deeper than 2,000 feet. It consists of two "wings" that extend radially away from the well in opposite directions. The direction is determined by the stresses in the area, and all the fractures in the same field follow closely the same direction. A few shallow fields in the world may have horizontal "pancake" fractures.

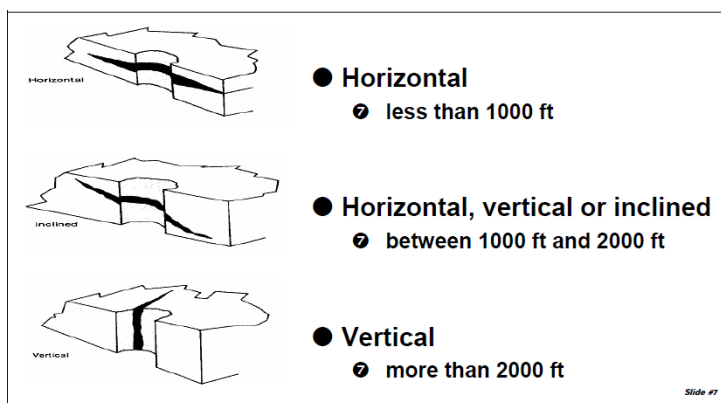

Figure 152 Fracture Orientation

The two vertical cracks become a “flow highway” for the slow bleeding or accumulation of oil or gas from the surface of the crack wall. The process works best in “tight” or low permeability formations (0.001 md to 10 md). Wells with higher permeability pay zones do not usually need this kind of stimulation, and it would have a very small effect on productivity of these good wells.

The process increases recoverable oil and gas, as well as improves the rate of production. Without it, many wells would be uneconomical to produce from the start and would never be drilled. Some 15 billion barrels of additional oil reserves have probably been added because of fracturing.

12.4 EQUIPMENT

12.4.1 Engines

All engines used during a fracturing treatment or high-pressure pumping job should have emergency shut downs, spark-proof ignition systems and water-cooled exhausts.

12.4.2 Pumps

Nearly all service companies use reciprocating triplex pumps for fracturing. Frac pumps are rated between 155 and 1100 hydraulic horsepower (HHP) and are capable of pumping fluid at maximum pressures of 5,000 to 20,000 psi.



Figure 153 Fracturing pump

Wide flexibility in pressure and rate can be achieved with frac pumps by changing plunger sizes and/or fluid ends. Larger diameter plungers are limited to low pumping pressures because of the crankshaft loading but are capable of much higher rates than smaller plungers. In general, it is best to use the largest diameter plunger available for the anticipated treating pressure. Large diameter plungers require fewer valve cycles to pump a given fluid volume and, hence, minimize valve failures due to valve and seat erosion by the abrasive proppant.

12.4.3 Intensifiers

Intensifiers are horizontal triplex pumps with 5-ft. strokes. They are powered by a hydraulic “pressure intensifier” with conventional frac pumps serving as prime movers. The greatest advantage of an intensifier is the relatively few pump strokes and valve actuations required to pump a given volume of fluid. These units have the capability of pumping large proppants in high concentrations at high pressures for sustained periods with a minimum of valve and seat erosion.

12.4.4 Blenders

Blending equipment is the heart of the fracturing operations. The secret to a good blending operation is production of a smooth, even distribution of sand in the fluid fed to the fracture pumps to prevent “slugging” (pulses of high sand concentration).

Blenders consist of two fluid transfer pumps and a mixing tub. The suction pump, which moves fluid from the frac tank into the blending tub, is either a positive displacement pump or a centrifugal pump. Frac fluid is mixed with proppant and other additives in the tub by mechanical agitation with auger screws or paddles or by hydraulic jets. A centrifugal pump moves the mixture from the tub and pressures it to 30-50 psi to feed the frac pumps. Blenders are available to handle 1 to 10 frac pumps at rates of virtually 0 to 100 BPM.

The standard screw or jet blender produces a smooth blend when low- viscosity oil or water is the fracturing fluid and the sand concentration is low. When a very viscous oil-base fluid is used, these blenders do not give enough agitation and must be modified. Normally, addition of an- other screw, additional jets, or some other mechanical agitation device will eliminate this problem.



Figure 154 Frac Blender

12.4.5 Frac Tanks

Most frac tanks have 500 bbl. capacity and are rented from the service company performing the job or from a tank rental company. For most purposes the working capacity of a 500 bbl. frac tank is 475 bbls or 20,000 gals. Also used are 200 bbl. mud tanks or lined earthen pits.

Clean frac tanks are hard to come by. Always inspect the frac tanks and have them steam cleaned, if necessary, to remove any residual material left over from a previous job.



Figure 155 Frac Tank

12.4.6 Standby Equipment Considerations

Experience in the area and with the service company determines this need. Normally 1 extra blender on big jobs is needed. Often 50-100% standby pumping equipment may be needed on very big jobs. The loss of a fracturing pump in the middle of an operation can lower the injection rate, causing a premature screen out or complete job shut-down. This is true whether the failure is in the driving engine, transmission train, or pumps themselves. Failures are likely, especially when large-diameter sand is to be pumped or when pressures above 6000 psi are expected, or when pumping longer than 2 hours.

12.4.7 Gauges and Controls

Have enough recording pressure gauges. Always monitor tubing, casing, and the manifold pump discharge line. Use velocity check valve type connections.

The greatest problem with blenders is their inaccuracy in metering sand to obtain accurate sand-fluid ratios. This problem is minimized if the density of the sand- fluid slurry exiting from the blender is measured instead of the individual sand and fluid rates going to the blender.

12.4.8 Bridge Plugs

Most retrievable bridge plugs are designed with a special fishing neck so that ball sealers, sand, or other material can be washed before removing the plug. The chief problem when using retrievable bridge plugs is plug removal. Serious complications can occur when excessive pressure is built up below the plug or when debris is dumped on top of the bridge plug, thereby sticking the plug in the casing. (Some bridge plugs are made so that it is easier to push the plug to the bottom rathole of the well rather than attempting to remove or drill out the plug).

12.4.9 Crossover Valve

- Permits high volume through tubing and casing.
- Rubber sleeve vulcanized to tubing I.D. Covers holes or ports Allows initial breakdown through tubing.
- Provides 2-4 times volume rate with same HHP.
- Can be closed at any time by reducing pressure on casing All proppant put down tubing.
- Can alter relative quantities to avoid a screen out Can reverse out in event of a screen out.
- Backflowing may clear a formation screen out Screen out in casing would require new treatment.
- Could also require cut and fish job.
- Cannot use with cross-link fluids without risk.
- Sand must be pumped down annulus since sand must be added before cross-linking.

12.4.10 Wellhead Equipment

When fracturing down tubing, the maximum surface frac pressure is governed by either the wellhead equipment or the burst limitation of the top joint of tubing. “Backing-up” the tubing with pressure in the annulus helps resist high pressure but does not increase the pressure limit of any tubing that is exposed above the ground. A 3,000-psi working pressure wellhead can be a substantial hindrance to a successful frac treatment and can be responsible for causing a frac treatment to be marginally successful rather than very successful.

When the pressure limiting component of a well system is above ground, it can usually be “upgraded” safely and reliably by one of these methods:

1. Isolating the wellhead from treating pressure
2. Substitution of a “Treating Tree” for the production Christmas tree
3. Special landing joints or “Top Out Joints” for working through blowout preventers or wellhead assemblies where conventional trees have not been installed.

12.4.11 Diverting Agents

Number of rubber balls injected should equal the number of perforations to be covered, plus 10-100 percent, based on experience.

12.4.12 Fluids

5% excess often planned to allow for amount left in the bottom of frac tanks Additional 5% excess above design volume is often ordered.

12.4.13 Frac String

The simplest and most economical means of fracturing a well is by pumping through existing wellhead equipment. This technique can be utilized where the tubing and packer are in good condition.

If the production tubing and packer are in good mechanical condition, and are to be used as the frac string, rods and pump will have to be removed, but the pump seating nipple presents no obstacle. If a well is on conventional gas lift (gas down annulus and production up tubing), the gas-lift valves need not be removed prior to fracturing, providing the ball checks on all gas-lift valves are holding to prevent frac fluid and proppants from entering the annulus. The above situations are generally the exceptions rather than the rule. Normally, production tubing or the existing packer will not meet requirements, or it requires excessive horsepower for friction, so the tubing must be pulled.



Figure 156 Rig-up Frac pumps to Well Head

Fracturing down the casing saves money on HHP because of the lower friction loss and thereby lower treating pressure. Casing is often not used as a fracture string on workovers because of pressure limitations (burst) of the surface pipe and because of the possibility of casing leaks, squeeze perforations, or completions in intervals other than those to be fractured.

If the well's existing production tubing is to be pulled and a frac string used the largest practical-size tubing should be utilized as a fracture string to minimize friction loss during the operations. However, other considerations such as availability, economics, or after-fracture workover requirements may limit the choice of diameters. Every attempt should be made to eliminate killing the well with heavy brine or mud after the treatment, which may damage the reservoir enough to reduce the benefits of or completely negate the fracturing treatment.

12.4.14 Packers

If a special fracturing string will be run in the well for the fracture treatment, a specialized retrievable packer will generally be furnished on a rental basis by the Service Company. Selection of the type of packer to be employed will depend on the wellbore configuration and experience in operation.

Frac fluids are made from oil, water, acid, emulsions, and foams. Each type of fluid has certain characteristics that make it a favorable choice for the engineer having a specific objective. Proppants are usually sand or sintered bauxite. The bauxite is a stronger proppant usually necessary to resist crushing at depths deeper than 11,000 feet.

The following discussions should help to get these jobs carried out with the highest level of success and with the least field problems.

12.4.15 Perforation Ball Sealers

Necessary attributes of balls:

- Size and density to be carried by fluid; buoyant balls reset well.
- Tough enough to resist extrusion (hard center bigger than perf hole) Readily free themselves when pressure is released.
- Heavy enough to settle to bottom if not buoyant.
- Must be drillable.

12.4.16 Foam Frac Equipment

- Nitrogen pumping units.
- Nitrogen transports.
- Sand intensifiers.



Figure 157 Foam Frac equipment on location

12.4.17 Proppant

Proppant needed to keep the fracture open. Sand and sintered bauxite are generally used. Fines in proppant severely reduce the production rate.

12.4.18 Radioactive Sand

Radioactive sand is sometimes used so that post-frac radioactivity logs will tell frac height. If radioactive sand will be used, place it in an isolated location until it is time to be used. If the radioactive sand is used only for tail-in, it may not give an accurate picture of the vertical extent of the fracture in the bottom of the zone.

12.5 IMPLEMENTING THE JOB

12.5.1 Site and Well Preparation

Perform any site preparation work required

- Remove any items that may be left on location from the drilling operation.
- Avoid the premature installation of any production equipment.
- Repair road to location; beware of deep ruts or the possibility of a quagmire in bad weather.
- Dredging of channels to inland water locations. Sloping the location to drain well is desirable.
- If water is sprayed on the ground to keep down dust, it should still permit any spilled oil to soak into the ground.

Well Preparation

- Pull tubing and/or make cleanout runs.
- Run baseline diagnostic surveys as specified by engineering.
- Install BOP or Tree Saver if anticipated maximum fracturing pressure exceeds the rated pressure of the Tree and Wellhead. If a BOP will be used, check it for proper pressure rating, rams, and operating condition.

12.5.2 Perforating

If an open-hole completion with a slotted liner or screen is to be fractured, the liner or screen must be perforated opposite the productive sand interval to prevent propping material from plugging the liner. Liners with 1/4" or larger shop-drilled holes, or liners with slots many times larger than the mean proppant diameter, need not be perforated prior to fracturing.

12.6 RIG-UP

Move-in and rig-up work should be completed as early as possible to allow adequate daylight time to complete pumping.

Early starts are also preferred to allow time for electric line diagnostic work such as temperature surveys and Gamma Ray logs at the end of the job.

On medium and large frac jobs, the Service Company should spot equipment and rig-up the day before. Otherwise, the Service Company should arrive at daybreak to rig-up.

The pulling unit or rig may be moved a safe distance from the well before pumping operations are started if the supervisor considers it necessary. When rig equipment is required for the fracturing job, only necessary engines will be operated.

Check that the required amounts of all materials are on hand as ordered. Get samples and check quality.

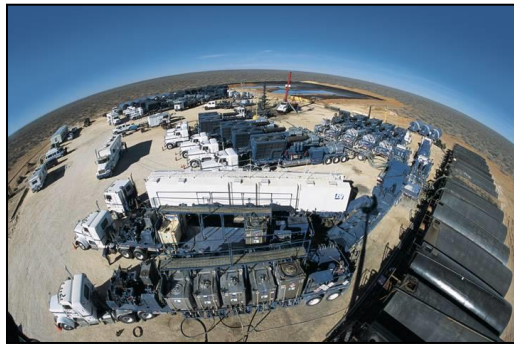

Figure 158 Rig-up of Fracturing Equipment

12.6.1 Proppant

- (1) Throw a handful in the air and check to see how much of a dust cloud is generated.
- (2) Put some in a glass of water and see whether the water turns cloudy.
- (3) Put some proppant in HCl and check for any dissolving action. If proppant not up to spec, notify engineering before allowing the treatment to begin.
- (4) Run sieve analysis to ensure the proppant/sand particle size distribution is as per plan.
- (5) Fluid samples — obtain continuously throughout the job.



Figure 159 Sand King

12.6.2 Placement of Equipment - Safety Considerations

- All personnel, vehicles, and equipment not needed for the fracturing operation will be removed to a safe distance. Unauthorized personnel should not be allowed to enter the work area. Vehicles equipped with radio-transmitting equipment must be moved a minimum distance of 200 feet (upwind) from the well and pumping equipment during the fracturing operations.
- All persons who approach to within 150 feet of the operations must remove matches, lighters, and cigarettes from their pockets and leave these articles in vehicles during the operation.
- Pumping trucks and tanks must be located cross-wind and at a minimum of 100 feet from the well, if possible. They must be headed away from the well to facilitate quick movement if fire should occur.
- Adequate fire-fighting equipment in good working condition should be provided and placed in strategic locations with trained personnel properly stationed during the job. All access roads must be kept clear.
- Never place oil in open tanks of truck mounted fracturing or cementing units.
- Electrically bond all trucks and blenders by means of a ground wire clip to a central point, such as the sand transport, to eliminate the possibility of static electricity generation. Ground the central point to a rod driven into the ground. Pour water around the rod if the ground is not moist.
- Use new ring gaskets when installing adapter flange on tree.
- All equipment must be grounded. Pumping an emulsion through hoses creates static electricity.
- Check that precautions are taken to prevent air from entering pump suction lines. Tie connecting hoses down within 2 feet of gauges.
- Install fracture pump controls at maximum feasible distance from pump trucks, discharge lines, and Christmas tree.
- Provide rate and pressure indicator at control point. Calibrate the digital readout and the paper recorder.
- Check operability of stand-by equipment to prevent being charged for and being disappointed by “basket cases”.

12.6.3 Fluid Mixing

To premix a treated fluid such as gelled water, pump the fluid through the blender, adding the desired quantity of material in the blender tub, and discharge the mixture back into the same tank. With suction and return lines located at different ends of the tank, a rolling action is produced which aids in mixing. Continued circulation through the blender, without adding material, will complete fluid mixing.

12.6.4 BOP

When a blowout preventer is to be used, it must be checked for proper pressure rating, rams, and operating condition. It must be tested to rated pressure prior to job performance.

Pressure Testing

The service company equipment should be pressure tested prior to job initiation. This is accomplished by shutting the valve at the wellhead and slowly increasing line pressure with the high-pressure pumps. General practice is to test to 1000 psi above the highest anticipated pumping pressure or to 80% of burst pressure and watch for leaks in the lines or equipment.

Connections must not be hammered or tightened while the lines contain pressure.

Lines must be tested with water; do not use oil or acid for pressure testing. After leaks, if any, are repaired, the lines must be retested. Stake down all lines between pump and tree after pressure testing satisfactorily. Check that the firefighting equipment is in good working condition. Install pressure relief valve on casing.

Install ball sealer injectors midway between the tree and pump discharge. Load ball injectors with ball sealers. Check for mechanical operation. It is good practice to witness the actual loading of the injectors.

Test operation of Intercom System!

12.7 RIG-DOWN

Bleed any fluid from the lines to a suitable tank or pit. A recording pressure gauge should be left on the well to record pressure decline, even after frac units leave location.

The well must be adequately secured if the well is left shut-in under pressure following treatment. Do not bleed off the wellhead pressure. Note: Pressure bleed off at the wellhead immediately after a fracture treatment can result in flowback of proppant into the wellbore. After extensive pumping and consequent cooling, the casing-tubing annulus must be monitored for pressure buildup due to annular fluid warm-up until equilibrium is reached.

12.7.1 Evaluation and Testing

Rig up wireline equipment and perform diagnostic surveys (such as temperature surveys, Gamma Ray logs, etc.) as specified by engineering. Allow at least 24 hours and preferably 48 hours for the fracture to “heal”, or close on the proppant, before producing the well.

13 WELL TESTING

13.1 OBJECTIVES

After studying this section, the trainees should be able to perform the following:

- Describe the function of well testing operation in well servicing.
- Describe the function of all components of the Rig Up equipment.
- Describe the preventive maintenance.
- Describe the operational procedures.
- Describe the rig up/rig down procedures related to well testing.
- Describe stimulation operator's general safety precautions and emergency response procedures.

13.2 OUTCOMES

Upon completing their training, the participants should be able to:

- Demonstrate knowledge of all well testing services and related products.
- Demonstrate proficient knowledge of the well testing and related products.
- Assist proficiently in well testing activities and operating, servicing and repairing equipment.

13.3 OVERVIEW

A "well test" is simply a period during which the production of the well is measured, either at the well head with portable well test equipment, or in a production facility.

Most well tests consist of changing the rate and observing the change in pressure caused by this change in rate. To perform a well test successfully one must be able to measure the time, the rate, the pressure, and control the rate. Well tests, if properly designed, can be used to estimate the following parameters:

- Flow conductance
- Skin factor
- Non-Darcy coefficient (multi-rate tests)
- Storativity
- Fractured reservoir parameters
- Fractured well parameters
- Drainage area
- Distance to faults
- Drainage shape

13.4 PURPOSE OF WELL TESTING

The purposes of well testing differs from exploration well to production well.

13.4.1 Exploration wells

- Fluid sampling (Primary reason).
- Measuring the initial pressure.
- Estimating a minimum reservoir volume.
- Evaluating the well permeability and skin effect.
- Identifying heterogeneities and boundaries.

13.4.2 Producing wells

- Verifying permeability and skin effect.
- Identifying fluid behavior.
- Estimating the average reservoir pressure.
- Confirming heterogeneities and boundaries.
- Assessing hydraulic connectivity.

13.5 TYPES OF WELL TESTING

13.5.1 Flow test

A Flow test is an operation on a well designed to demonstrate the existence of moveable petroleum in a reservoir by establishing flow to the surface and/or to provide an indication of the potential productivity of that reservoir. Some flow tests, such as drill stem tests (DSTs), are performed in the open hole. A DST is used to obtain reservoir fluid samples, static bottom hole pressure measurements, indications of productivity and short-term flow and pressure buildup tests to estimate permeability and damage extent.

Other flow tests, such as single-point tests and multi-point tests, are performed after the well has been cased. Single-point tests typically involve a measurement or estimate of initial or average reservoir pressure and a flow rate and flowing bottom hole pressure measurement. Multi-point tests are used to establish gas well deliverability and absolute open flow potential.

13.5.2 RFT

To check pressure equilibrium and thus homogeneity wells can be tested using wireline-conveyed tools, either in casing or open-hole. These tools include RFT, MDT, etc. and are typically run to the desired depth before actuating levers or other devices seal them against the side of the wellbore.

13.5.3 Drill-Stem test

- In newly developed reservoirs or high-risk developments it may be worthwhile to test the well before completing it or installing full production facilities. This is usually done with a drilling rig on-site, and the string through which the well is produced is manipulated by the drilling rig.
- These are well tests conducted with the drill string still in the hole. Often referred to as DST, these tests are usually conducted with a downhole shut-in tool that allows the well to be opened and closed at the bottom of the hole with a surface-actuated valve. One or more pressure gauges are customarily mounted into the DST tool and are read and interpreted after the test is completed. The tool includes a surface actuated packer that can isolate the formation from the annulus between the drill string and the casing, thereby forcing any produced fluids to enter only the drill string. By closing in the well at the bottom, after flow is minimized and analysis is simplified, especially for formations with low flow rates. The drill string is sometimes filled with an inert gas, usually nitrogen, for these tests. With low-permeability formations, or where the production is mostly water and the formation pressure is too low to lift water to the surface, surface production may never be observed. In these cases, the volume of fluids produced into the drill string is calculated and an analysis can be made without obtaining surface production.

- Occasionally, operators may wish to avoid surface production entirely for safety or environmental reasons and produce only that amount that can be contained in the drill string. This is accomplished by closing the surface valve when the bottom hole valve is opened. These tests are called closed-chamber tests. Drill stem tests are typically performed on exploration wells and are often the key to determining whether a well has found a commercial hydrocarbon reservoir. The formation often is not cased prior to these tests, and the contents of the reservoir are frequently unknown at this point, so obtaining fluid samples is usually a major consideration. Also, pressure is at its highest point, and the reservoir fluids may contain hydrogen sulfide, so these tests can carry considerable risk for rig personnel. The most common test sequence consists of a short flow period, perhaps five or ten minutes, followed by a buildup period of about an hour that is used to determine initial reservoir pressure. This is followed by a flow period of 4 to 24 hours to establish stable flow to the surface, if possible, and followed by the final shut-in or buildup test that is used to determine permeability thickness and flow potential.
- The characteristic plot of pressure versus time obtained from the mechanical recording of pressure gauges in a DST tool. Pressure rises as the tool is lowered into the hole and the hydrostatic head above the tool increases. The pressure stabilizes when the tool reaches bottom and then moves when the packer is set.
- Pressure drops immediately upon opening of the downhole valve to match the pressure in the drill string, and then rises as fluid flows into the string. When the downhole valve is closed, the pressure buildup period begins immediately and continues until the valve is closed again (Figure 161).

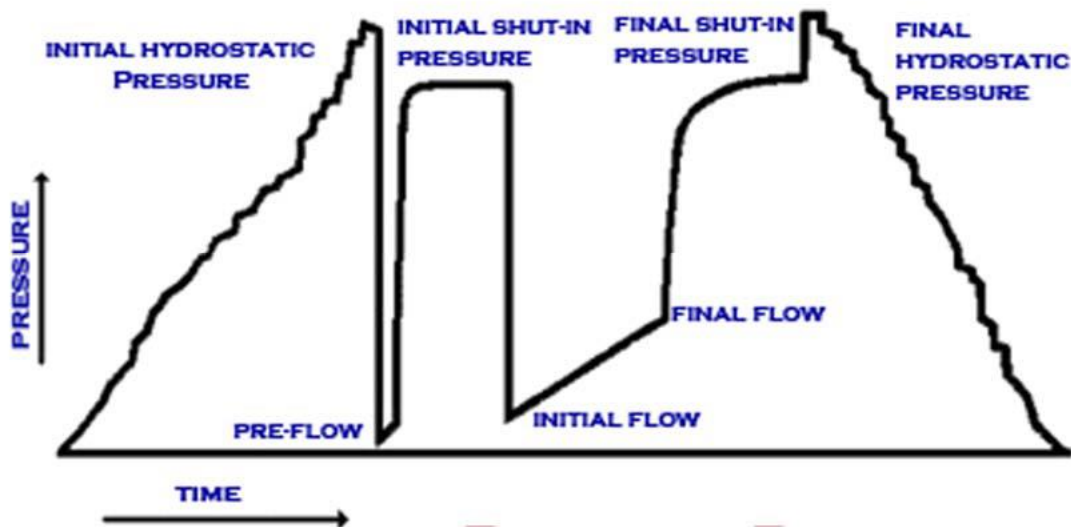

Figure 160 Pressure Recovery Chart

13.5.4 Drawdown test

A drawdown test is one in which the rate is held approximately constant while the well pressure is measured. Shut in the well till pressure reaches static level and then flowing the well at a constant rate, q & measuring P_{wf} .

Advantages

- Suitable in new wells. With No need to lose production, reservoir size can be determined.

Disadvantages

- Difficult to maintain constant production rate. Long shut in so that P_i is achieved is required.

13.5.5 Multirate tests

Accounts for variable rate history and applications.

- Rate variations
- kh product, Pr
- Boundary configurations
- Skin
- FE
- PI

Advantages

No problems with variable flow rate, no loss of production, and reduced wellbore storage.

Disadvantages

Rate fluctuations are difficult to measure on a continuous basis.

13.5.6 Production test

A production test is just like a drawdown test, except that it is generally run for a longer period.

13.5.7 Buildup test

This is the most preferred well testing technique. The well is first produced at a constant rate till pressure is stabilized and then the well is shut in. Pressure is recorded as a function of time.

Advantages

Precise control of rate and P^* can be determined.

Disadvantages

Loss of production due to shut in.

13.5.8 Banker's Test

This is a productivity test to demonstrate that adequate rates can be obtained from the well.

13.5.9 Interference test

This test is designed to give large-scale reservoir property trends which can give improved estimates of directional permeability.

13.6 WELL TESTING EQUIPMENT

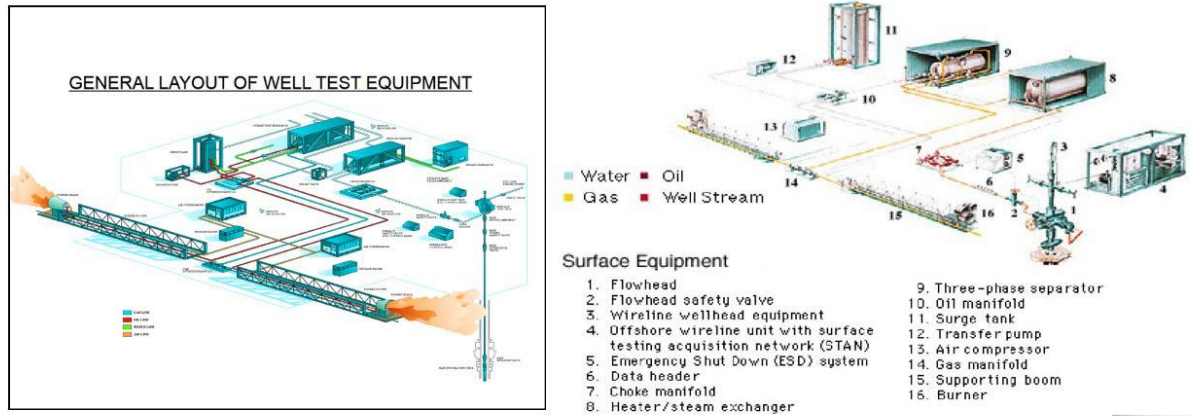

Figure 161 General Layout

13.6.1 Surface Safety Valve “SSV”

The surface safety valve (SSV) is a hydraulically actuated fail-safe gate valve for testing oil and gas wells with high flow rates (>8,000 bbl/d [$>1,280 \text{ m}^3/\text{d}$] or 30,000,000 ft³/d [$>850,000 \text{ m}^3/\text{d}$]), high pressures (>5,000 psi [$>34 \text{ MPa}$]), or for detecting H₂S.

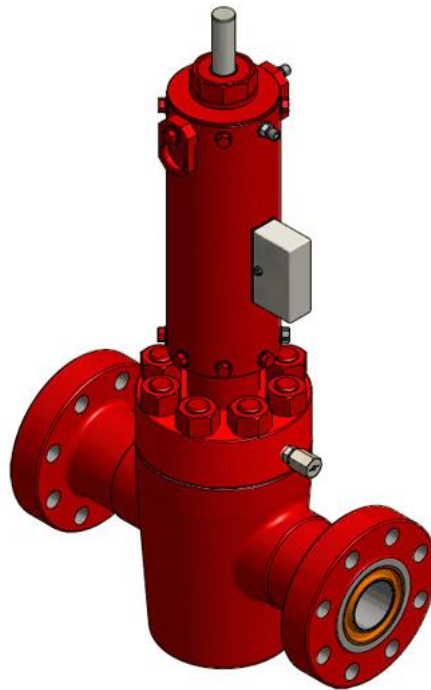

Figure 162 Surface Safety Valve SSV

13.6.2 Floor Choke Manifold

The floor choke manifold (FMF) consists of four manual valves, or five if a bypass valve is included. It includes a variable choke box, fixed choke box, and several pressure or sampling ports and thermo-wells to monitor pressure, temperature, and fluid characteristics.

13.6.3 Steam-Heat Exchanger

Steam-heat exchangers are used to raise the temperature of the well's effluents to prevent hydrate formation, reduce viscosity, and break down emulsions for efficient separation of oil and water.

13.6.4 Conventional Horizontal Separator

The conventional horizontal separator is designed to separate well effluent into three phases for offshore well testing. It can operate as a stand-alone unit or in combination with the Phase Tester portable multiphase well testing equipment with Vx multiphase well testing technology, reducing dependency on the separation process for high-quality flow measurements.

13.6.5 Vertical Surge Tank

The vertical surge tank (VST) H₂S service vessel is designed to store liquid hydrocarbons after separation.

It is used to measure liquid flow rates and the combined shrinkage and meter factor.

13.6.6 High-Efficiency Burners

The Green Dragon high-efficiency burner provides clean disposal of the oil produced during well testing.

This burner consists of pneumatic actuators on the oil and air valves with pneumatic control panel for high efficiency burning and rotation control.

13.6.7 Surface Test Tree

Surface Test Tree with swivel supports the test string and provides a means of surface well control when completing, testing, or performing live well intervention operations.

Two wing valves connect to the kill and flow manifolds to control the flow of the wellbore fluids. Valve actuators are controlled from a console located on the rig floor and link to the emergency shutdown system for the flow wing valve.

This configuration allows for remote shut-in of the well at the Surface Test Tree.

The handling sub attached to the top of the Surface Test Tree valve block is used to tension the Surface Test Tree and the riser or landing string.

The handling sub also provides an interface to the surface wireline or coiled tubing equipment.

A dynamic swivel is located between the main valve block and the lower master valve, allowing rotation of the string without rotating the Surface Test Tree, and preventing any rig movement from transferring torque into the riser or landing string.



Figure 163 Surface Test Tree

13.6.8 Emergency Shutdown (ESD) System

An ESD system with a minimum of two remote control stations are recommended for all well test operations.

They are designed to pneumatically control the hydraulic flow head valve or any other single action, fail-safe hydraulically activated valve and to generate an emergency shutdown signal. The remote stations are to be located at the separator and in an area removed from all pressurized equipment on an escape route.

During testing operations, emergency shutdown system controls surface safety valve on the flow head and permits manual or remote closure in response to a pipe leak or break, equipment malfunction, fire, or similar emergency.

The ESD system is also used to reopen the valve and, if needed, can control an additional surface safety valve upstream of the choke.

Pressure from the system's air-driven hydraulic pump is applied to open the valves and released to close them.

Applications

- All well test operations
- H₂S environments and when wellhead pressures are greater than 34 MPa [5,000 psi]



Figure 164 Emergency Shutdown System

13.6.9 Choke Manifold

Choke manifold consists of four manual gate valves (five if a bypass valve is included). It is used to control the flow rate and reduces well pressure before the flow enters the processing equipment. The manifold also includes a positive choke box, an adjustable choke, and several pressure or sampling ports and thermowells to monitor pressure, temperature, and fluid characteristics.



Figure 165 Choke manifold

Applications

- Onshore and offshore oil and gas well testing and cleanup after drilling or workover operations.
- Flowback after stimulation or workover operations.

13.6.10 Choke Bean

Choke bean used to control the flow of fluids, usually mounted on Choke Manifold. An Adjustable choke bean contains a replaceable insert, or bean, made from hardened steel or similar durable material. The insert is manufactured with a precise diameter hole that forms the choke through which all fluids must pass. Choke inserts are available in a complete range of sizes, generally identified by choke diameter stated in 64ths of an inch; for example, a "32 bean" is equivalent to a 1/2-in. choke diameter.

Types of Choke bean:

13.6.10.1 Adjustable Choke Bean.

Can be adjusted by a handle. Can be repaired when it needed or in case of damage. Easy to control pressure while coil tubing or wire line operations.

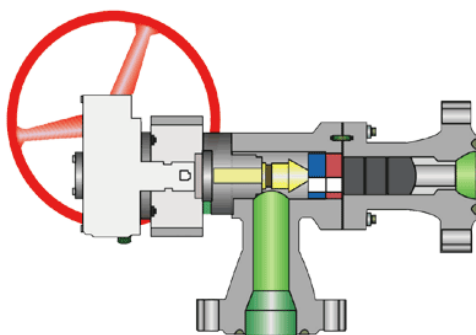

Figure 166 Adjustable Choke Bean

13.6.10.2 Fixed Choke Bean.

Fixed Choke size. Can be adjusted only by replacing the Bean by another size as bean up to bigger or bean down to smaller.



Figure 167 Fixed choke bean

13.6.11 Data Header

Data Header is a short sub connected to the upstream side of the choke manifold to provide additional pressure gauge, thermowell, and sampling or injection ports.

The data header allows connection of pressure and temperature monitoring equipment, as well as sampling or injection equipment.



Figure 168 Data Header

Various models are available for different well conditions (pressures, temperatures, and flow rates) and various connections, such as hammer unions and API-6A flanges.

All data headers are manufactured under Type Approval or Design Verification Review and are provided with a Certificate of Conformity and full quality file.

Applications

- Any well test or cleanup setup where additional pressure, temperature, sampling, or injection ports are needed on the upstream side of the choke manifold.

13.6.12 3-Phase Test Separator

- 3-phase test separator is an instrumented pressure vessel designed to efficiently separate well effluent into oil, gas and water for onshore and offshore well testing.
- The 3-phase test separator can operate as a stand-alone unit or in combination with the surge tank, reducing the dependency on the separation process for high-quality flow measurements.
- The 3-phase test separator typically consists of a vessel, an oil flow-measuring system with dual meters, a flow-measuring system for gas, several sampling points for each effluent phase, and two relief valves to protect the vessel against overpressure. Most separators are also equipped to measure water flow rate.
- To provide accurate measurements, the 3-phase test separator is fitted with pneumatic regulators that maintain a constant pressure and a constant liquid level inside the vessel by control valves on the oil and gas outlets.
- The 3-phase test separator is fitted with a deflector plate, coalescing plates, a foam breaker, a vortex breaker, a weir plate, and a mist extractor.
- These components reduce the risk of carryover (liquid in gas line) and carry under (gas in liquid line) that would affect the flow rate measurement accuracy.

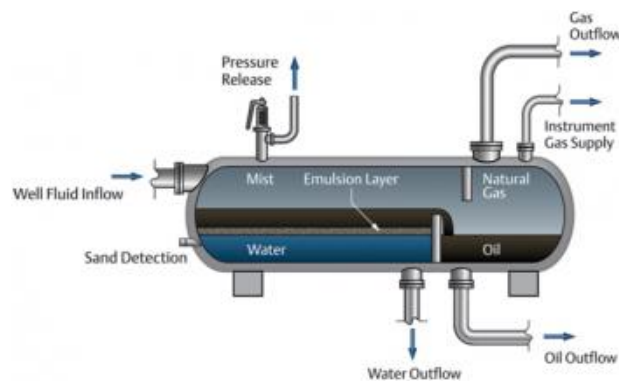

Figure 169 Three phase separator

Applications

- Onshore and offshore exploration, development, and production well testing after cleanup.

13.6.13 Vertical Surge Tank

- Vertical surge tank is an H₂S service vessel designed to store liquid hydrocarbons after separation.
- The surge tank is used to measure liquid flow rates, as well as the combined shrinkage and meter factor. It can also be used as a second stage separator and hold a constant backpressure by using its automatic pressure control valve on the gas outlet.
- The surge tank usually consists of a single or double compartment vessel and a level measuring system with sight glasses or magnetic levels. To prevent overpressure and overfilling, the surge tank is fitted with a pressure-relief valve and a high- and low-level alarm system.
- Surge tanks are designed with a diverter, a vortex breaker, and stiffening rings capable of withstanding a vacuum in the vessel.
- They are fitted with sampling, pressure, and temperature ports. A bypass manifold is also included.
- All surge tanks are shock-protected by a frame, and operate in the vertical position, even they are transported in a horizontal position.



Figure 170 Surge tank

Applications

- Onshore and offshore exploration and development oil and gas well testing.
- Production wells.

13.6.14 Atmospheric Gauge Tank

The atmospheric gauge tank, a non-pressurized vessel, is used to measure low flow rates or to calibrate metering devices on the separator oil lines in a testing system. When the flow rate is too low to efficiently drive oil to the burners, the tanks can also be used for temporarily storing the oil.



Figure 171 Atmospheric Gauge Tank

These skid-mounted units have two compartments. As a transfer pump empties one compartment, the other is being filled. A sight-glass level built into each tank is used to calculate the change in volume based on the physical dimensions of the tank.

Safety features include flame arrestors on each vent from the tank, a grounding strap, and a shearing roof that opens at 3.45 kPa [0.5 psi] burst pressure in the event the vessel is over pressured accidentally. The grounding strap attached to the tank prevents a static charge buildup. The atmospheric gauge tank is frequently part of the standard equipment for well testing. However it cannot be used when H₂S is present in the effluent because the gas released from the tank is vented into the atmosphere, and that would be hazardous to personnel in the area.

Applications

- Measure low liquid flow rates from a separator.
- Calibrate oil meters mounted on the separator oil lines.
- Measure a large volume of oil at atmospheric pressure.
- Determine the shrinkage factor.

13.6.15 Oil and Gas Manifold

- Oil and gas manifold divert oil or gas, without flow interruption, from the separator to crude oil burner for disposal, to surge tank or gauge tank for measurements or storage, or to a production line.
- Oil and gas manifold also isolate the test equipment to prevent flow interruption if the testing equipment is pulled out of service temporarily.



Figure 172 Oil and Gas Manifold

The oil manifold typically consists of five ball valves arranged as a manifold and is skid-mounted. The gas manifold is fitted with two ball valves and mounted on a skid.

Oil and gas manifold valves adopt a proven metal-to-metal, double-sealing design to resist harsh environment operations. All models comply with all applicable standards, such as API Spec. 6D and NACE MR 0175.

Applications

Exploration, development, and production wells using surface well testing equipment.

13.6.16 Crude Oil Transfer Pumps

- Crude oil transfer pumps are designed to pump oil from a tank to a burner or from a tank into an existing flowline.
- The characteristics of the fluid being pumped and the specific application for the pump determine which pump technology is most suitable.



Figure 173 Crude oil transfer pumps

Applications

- Well testing surge tanks or gauge tank transfer.
- ReInjection of separator oil into an existing flowline.
- Pump liquids to a tanker Benefits.

13.6.17 Gas Flare with Igniter

Gas flare or flare stack are used for exploration, drilling and production well.



Figure 174 Igniter

13.6.18 Crude Oil Burner

- The crude oil burner is a single-head, 3-nozzle, oil and gas burner for onshore and offshore exploration and development well testing and cleanup. It provides an efficient and cost-effective alternative to oil storage.



Figure 175 Burner

- The burner geometry makes extensive use of pneumatic atomization and enhanced air induction.
- The burner is equipped with one or two pilots, a flame-front ignition system. A built-in water screen to reduce heat radiation.
- It has been proved that Crude Oil Burner is highly efficient with all types of oil, particularly heavy and waxy oils.
- Crude oil burner control manifold is used to tune the flowrates of crude oil, gas and air into smokeless combustion.
- it also mixes gas and air, or gas and oil in advance.

Applications

- Offshore and onshore exploration and development well testing and cleanup operations.
- Operations in environmentally sensitive areas.
- Heavy and waxy oil production.

Benefits

- Reduces environmental impact during well testing.
- Provides an efficient and cost-effective alternative to oil storage.
- Accommodates low oil flow rates and adverse wind conditions.

13.6.19 Steam Heat Exchanger

- Steam-heat exchangers are used to raise the temperature of well effluents to prevent hydrate formation, reduce viscosity, and break down emulsions for efficient separation of oil and water. Because the steam heat exchangers virtually eliminate fire risk, they are used on offshore platforms and in other work conditions where safety regulations do not permit the use of indirect-fired heaters.



Figure 176 Steam exchanger

- The steam-heat exchanger requires an adequate steam supply for operation. Some rigs have enough steam supply, but usually a steam generator is required.
- Steam enters the vessel through an automatic control valve. The vessel contains an internal tubing bundle through which the effluent passes, a steam trap containing a steam condensate outlet, a safety relief valve, and a temperature controller.
- The vessel, which is equipped with two 152-mm [6-in] safety valves and a split coil, 106 mm by 106 mm [4 in by 4 in], is insulated with glass wool and an aluminum jacket.
- Heat from the steam is transferred to the tubing bundle and, in turn, to the effluent.
- A choke—with a 2-in seat, and a 3-in manifold equipped with three 31/16-in gate valves—is located between the effluent inlet and outlet.
- It allows the effluent to be preheated before and after the pressure is reduced at the choke.
- All steam heat exchanger models are skid mounted.



HALLIBURTON

Schlumberger



